

International  
**IR** Rectifier

# REFERENCE DESIGN

**IRMCS2013**

International Rectifier • 233 Kansas Street, El Segundo, CA 90245 | USA

## **IRMCS2013**

Encoder Based Low Voltage Servo Drive  
Design Platform

## Encoder Based Low Voltage Servo Drive Design Platform

### Features

- Low cost complete AC servo drive design platform
- IRMCK201 IC for complete servo control
- Simple design with IR2175 current sensing HVIC
- 48V/350W output power with MOSFET inverter
- High bandwidth torque loop response
- Flexible drive configuration (PMAC or induction motor)
- Quadrature encoder interface
- Low cost A/D interface with multiplexer
- ServoDesigner™ tool for easy operation
- RS232C and fast SPI interface (standard)
- Parallel interface for microcontroller expansion or debug port
- Over-current and ground fault protection
- Over-voltage / Under-voltage protection
- Dynamic Braking control with brake MOSFET/FWD
- Discrete I/Os (START, STOP, FAULT, FLTCLR, SYNC, IFBCAL, PWMACTIVE)
- Configuration data retention at power up/down

### Product Summary

Current loop bandwidth (-3dB)	5 kHz (typ)
Speed loop bandwidth (adjustable)	400 Hz (typ)
PWM carrier frequency	70 kHz max
Hardware current loop execution time	6 μsec
Enhanced low speed regulation by 1/T algorithm	
Continuous output current	6 Arms @20KHz PWM
Overload output current	18 Arms (3 secs)
Max SPI comm. speed	6 MHz
Slave SPI configuration	
Max RS232C speed	57.6 kbps
Input dc voltage range	22 to 50 V (typical)

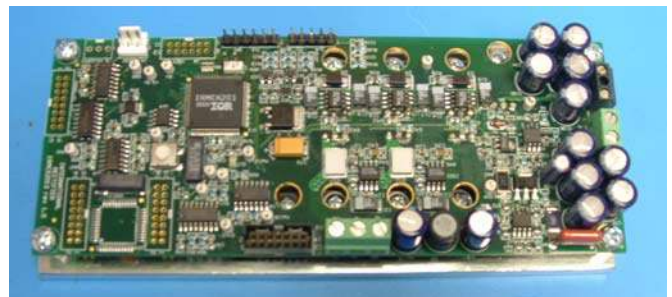

### Description

IRMCS2013 is a complete servo drive design platform for low voltage AC servo drive applications up to 350W. The system contains the latest advanced motion control IC, IRMCK201, and the ServoDesigner™ software. The complete B/Ms and schematics are provided so that the user can adapt and tailor the design per application needs. The system does not require any software code development due to unique Motion Control Engine implemented in the IRMCK201 IC. User can readily evaluate high performance servo control without spending development effort usually required in the traditional DSP or microcontroller based system. IRMCS2013 contains advanced iMOTION™ chipset such as IR2175 monolithic current sensing ICs and IR2106 gate drive ICs, which enable simple and cost effective motion control design.



## Table of Contents

1. Overview .....	4
2. Getting Started .....	5
2.1 Safety Precautions .....	5
2.2 Unpacking and Inspecting.....	6
3. Preparing the Motor .....	7
3.1 Readily Drivable Motor List .....	7
3.2 Assembling Encoder Connector .....	7
3.3 Motor Power Cable .....	7
3.4 Assembling Serial Connector.....	7
4. Hardware Installation .....	8
4.1 Safety Precautions .....	8
4.2 Input Power Wiring.....	9
4.3 Motor Wiring .....	9
4.4 Encoder Connection .....	10
4.5 RS232 Connection .....	10
5. Software Installation .....	11
5.1 Installing from the CD .....	11
5.2 ServoDesigner Startup .....	11
Step 1. RS232 Connection .....	11
Step 2. Numeric Format .....	11
6. Running the System .....	13
6.1 Power-On .....	13
6.2 Running motor with ServoDesigner.....	13
Step 1. Opening the Configuration File .....	13
Step 2. Checking Communication Status .....	13
Step 3. Motor Configuration .....	14
Step 4. Starting Angle .....	14
Step 5. Running the Motor .....	14
Step 6. Reference Speed.....	14
Step 7. Drive Status.....	15
7. Motion Control Engine .....	16
7.1 Motion Control Engine (MCE) Based Complete Servo Control.....	16
8. New Motor Adaptation .....	17
9. Appendix.....	19
9.1 External I/O .....	19
9.2 RS232C Connector .....	19
9.3 Parallel Interface Port.....	20
9.4 SPI Port .....	23
10. Specifications .....	24



## List of Figures

Figure 1. IRMCS2013 System Block Diagram.....	4
Figure 2. Encoder Interface Connector, J3.....	7
Figure 3. Location of Power Connector, J2 .....	9
Figure 4. Location of Motor Wiring Connection, J12 .....	9
Figure 5. Location of Encoder Connector, J3 .....	10
Figure 6. Location of RS232 Connector, J4.....	10
Figure 7. The Connection Dialog.....	11
Figure 8. The Numeric Display Format Dialog .....	12
Figure 9. Open a Configuration File .....	13
Figure 10. Communication Status Indicator .....	14
Figure 11. Setup for Reference Speed Function .....	15
Figure 12. IRMCK201 Based Complete Servo Control .....	16
Figure 13. EXCEL Spreadsheet Inputs .....	18
Figure 14. External I/O Connector, J6 .....	19
Figure 15. RS232C Connector, J4 .....	19
Figure 16. Parallel Interface Port, J7.....	20
Figure 17. Host Parallel Read Cycle Timing .....	21
Figure 18. Host Parallel Write Cycle Timing .....	22
Figure 19. SPI Timing.....	23

## List of Tables

Table 1. Serial Cable Connections .....	7
Table 2. Motor Connections.....	9
Table 3. Microprocessor Interface Module Signal Definitions .....	20
Table 4. Host Parallel Read Cycle Timing .....	21
Table 5. Host Parallel Write Cycle Timing .....	22
Table 6. SPI Timing .....	23
Table 7. IRMCS2013 Electrical Specification .....	24

## 1. Overview

The IRMCS2013 is a low voltage design platform for a complete servo drive system based on IRMCK201 IC. The system is based on configurable Motion Control Engine implemented by hardware logics in the IRMCK201. The system has a simple and low cost yet very flexible structure, made possible by advanced IR motion components including the IR2106 gate drive high voltage IC, and IR2175 monolithic current sensing high voltage IC. These components together with IRMCK201 IC simplify hardware construction, and perform complete servo amplifier functions. Figure 1 shows the IRMCS2013 system block diagram. Since all control logic is implemented in hardware logic as opposed to software program, unmatched parallel computation is achieved resulting in high bandwidth torque control.

Despite the fact that technology is based on hardware logic implementation, its design flexibility allows the user to configure different types of motors, position feedback devices, and communication protocols. The system also allows feedforward control in addition to existing PI control.

Design cycle time can be greatly shortened. Unlike a traditional DSP or microcontroller, the architecture is based on configurable register interface and does not require any programming to complete customization for specific application needs. The user only has to configure the drive using ServoDesigner™ interactive design tool and it takes just a matter of hours instead of months and years.

Once the user become satisfied with function and performance, he can generate his own design using IRMCS2013 schematics and B/Ms.

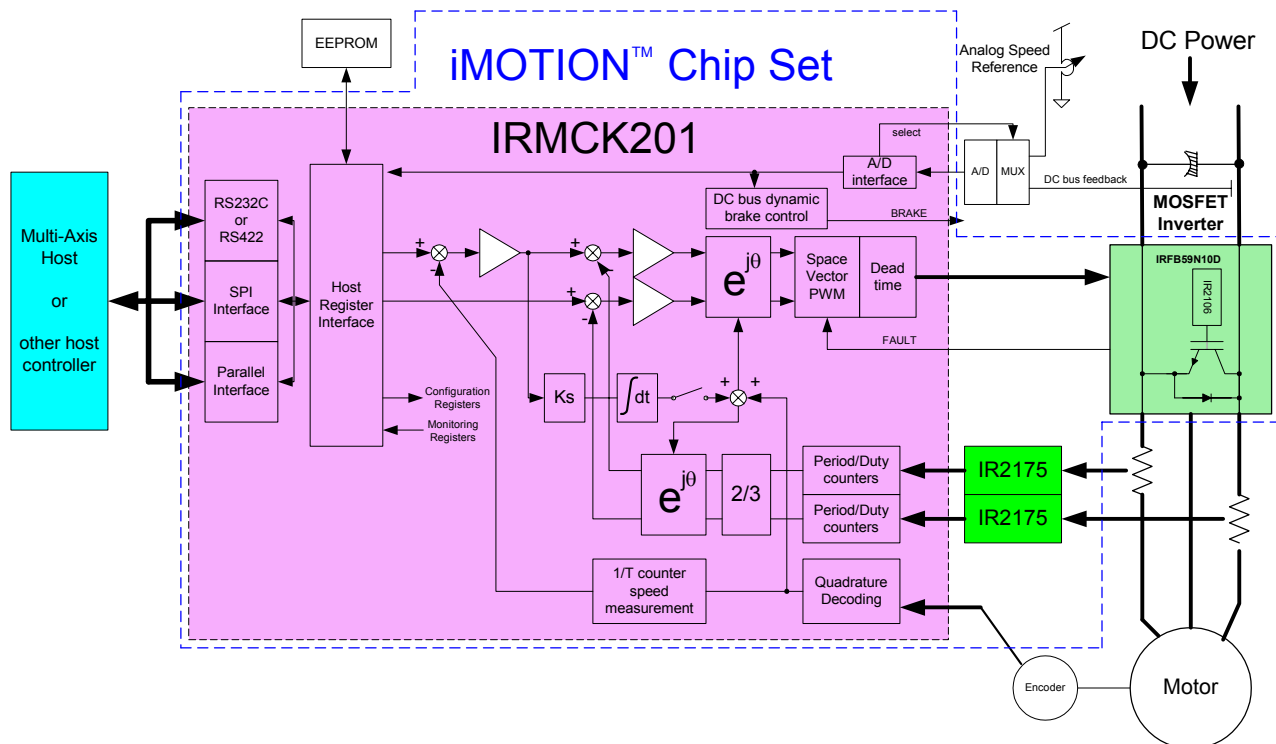
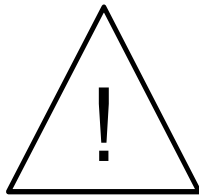

Figure 1. IRMCS2013 System Block Diagram

## 2. Getting Started

### 2.1 Safety Precautions

In addition to the precautions listed throughout this manual, you must read and understand the following statements regarding hazards associated with AC servo development system.



**ATTENTION:** Some ground potential of the IRMCS2013 system may be kept high voltage potential while power is on. When measuring voltage waveform by oscilloscope, the scope ground needs to be isolated. Failure to do so may result in personal injury or death. Darkened display LED is not an indication that capacitors have discharged to safe voltage levels.

---



**ATTENTION:** The IRMCS2013 system contains high voltage capacitors which take time to discharge after removal of main supply. Before working on drive system, ensure isolation of mains supply from line inputs. Wait three minutes for capacitors to discharge to safe voltage levels. Failure to do so may result in personal injury or death. Darkened display LED is not an indication that capacitors have discharged to safe voltage levels.

---



**ATTENTION:** Only personnel familiar with the drive and associated machinery should plan or implement the installation, start-up, and subsequent maintenance of the system. Failure to comply may result in personal injury and/or equipment damage.

---



**ATTENTION:** The surface temperatures of the drive may become hot, which may cause injury.

---



**ATTENTION:** The IRMCS2013 system contains ESD (Electrostatic Discharge) sensitive parts and assemblies. Static control precautions are required when installing, testing, servicing or repairing this assembly. Component damage may result if ESD control procedures are not followed. If you are not familiar with static control procedures, reference applicable ESD protection handbook and guideline.

---

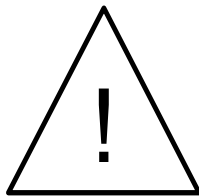

**ATTENTION:** An incorrectly applied or installed drive can result in component damage or reduction in product life. Wiring or application errors such as undersizing the motor, supplying an incorrect or inadequate AC supply, or excessive ambient temperatures may result in system malfunction.

---

## 2.2 Unpacking and Inspecting

The IRMCS2013 system is shipped with packing materials that need to be removed prior to installation.

---



**ATTENTION:** Failure to remove all debris and packing materials, which are unnecessary for system installation, may result in overheating or abnormal operating condition.

---

After unpacking, check the items. The following hardware pieces are contained in the IRMCS2013 system.

- IRMCS2013 board with integrated heat sink
- Serial RS232C cable with 9-pin D-sub connectors for ServoDesigner™ development tool
- Installation CD

Before you install and start up the system, check if there is any damaged component. In that case, stop proceeding and contact our technical support.

### 3. Preparing the Motor

#### 3.1 Readily Drivable Motor List

If the motor is one of the following, it can be run immediately without commissioning.

- Sanyo Denki 70W 8-pole servo motor with 2000-pulse encoder (P50B05007AXS7Z)
- Glentek 160W 4-pole servo motor with 2000-pulse encoder (GMB2005-8-N-02121109)

If any other motor is used, adaptation and re-configuration is required, which can be accomplished by using the ServoDesigner™ tool and the “IRMCx201-DriveParams.xls” file

#### 3.2 Assembling Encoder Connector

Prepare the connector assembly to the encoder cables.

- Assemble 14-pin male connector (Digikey part number WM18046-ND), referring to Figure 2.
- Make sure that the encoder is a 5V type. If it is not a 5V type, proper modification is required.

For permanent magnet motors:

- Eleven pins are used: A+ (pin 2), A- (pin 3), B+ (pin 4), B- (pin 5), Z+ (pin 6), Z- (pin 7), HALL\_A (pin 10), HALL\_B (pin 11), HALL\_C (pin 12), 5V(pin 1 or pin 9) and GND (pin 8 or pin 14).
- If hall sensors have differential output, connect only positive sides and leave negative sides open.

For induction motors:

- Only six pins are used because z-pulse is not necessary for an induction machine. The six pins are: A+ (pin 2), A- (pin 3), B+ (pin 4), B- (pin 5), 5V(pin 1 or pin 9) and GND (pin 8 or pin 14).
- Disable Z\_pulse by connecting Z+ to GND and Z- to 5V.

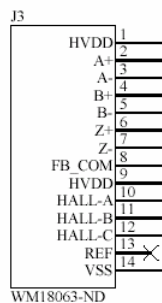

Sanyo Denki’s encoder cable wire:

- A+ = Blue,      A- = Brown
- B+ = Green,    B- = Purple
- Z+ = White,    Z- = Yellow
- 5V = Red,      VSS (GND) = Black

This is a wire-saving type encoder. Hall signals are multiplexed with encoder A, B and Z

**Figure 2. Encoder Interface Connector, J3**

#### 3.3 Motor Power Cable

If necessary, prepare the motor power cable. Proper size and length of cable should be used.

#### 3.4 Assembling Serial Connector

Prepare the connector assembly. One side is female D-sub 9 connector and the other side is 3-pin receptacle (Digikey part number A19491-ND). Connect two connectors as shown in Table 1.

Signal	Female D-sub 9	3-pin receptacle
Tx	Pin 2	Pin 1
Rx	Pin 3	Pin 2
GND	Pin 5	Pin 3

**Table 1. Serial Cable Connections**



## 4. Hardware Installation

### 4.1 Safety Precautions

---



**ATTENTION:** Remove and lock out power from the drive before you disconnect or reconnect wires or perform service. Wait three minutes after removing power to discharge the bus voltage. Do not attempt to service the drive until bus voltage has discharged to zero. Failure to do so may result in bodily injury or death.

---



**ATTENTION:** The drive is intended to be commanded by control input that will start and stop the motor. A device that routinely disconnects then reapplies input power to the drive for the purpose of starting and stopping the motor should not be used. Failure to follow this guideline may result in damage of equipment, and/or bodily injury or death.

---



**ATTENTION:** Do not connect power factor correction capacitors to drive output terminals U, V, and W. Failure to do so may result in equipment damage or bodily injury.

---

## 4.2 Input Power Wiring

Connect DC 48V power to J2 (2-pin, green) as shown in Figure 3. **Please pay attention to the polarity.** Connecting backward may cause damage to the board.

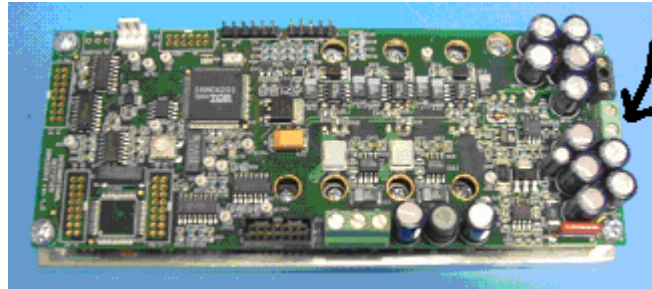
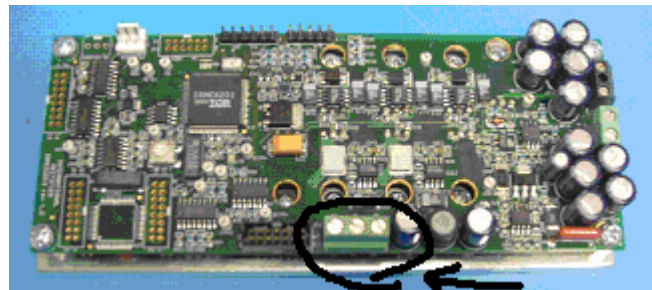

**Figure 3. Location of Power Connector, J2**

Proper size and length of cable should be used.

## 4.3 Motor Wiring

Connect motor power wires to J12 (3-pin, green) of IRMCS2013 board as shown in Figure 4.



**Figure 4. Location of Motor Wiring Connection, J12**

For Sanyo Denki (P50B05007AXS7Z) or Glentek (GMB2005-8-N-02121109), the colored wires should be connected to the associated pins of the IRMCS2013 board as shown in Table 2.

Sanyo Denki's motor cable wire	Glentek motor cable wire	J12 pin
RED	RED (pin A)	U
WHITE	BLUE (pin C)	V
BLACK	BLACK (pin B)	W
GREEN/YELLOW	GREEN (pin D)	Not available

**Table 2. Motor Connections**

## 4.4 Encoder Connection

Plug the encoder connector into J3 as shown in Figure 5. Make sure that encoder signals are connected properly. Incorrect connection of encoder signals will result in improper rotor position and/or nuisance faults.

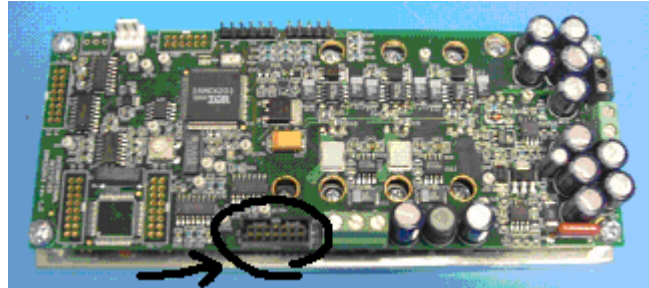

**Figure 5. Location of Encoder Connector, J3**

## 4.5 RS232 Connection

Connect the serial cable between the computer COM port and the connector assembly made as described in chapter 3.4. Connect the other side to J4 as shown in Figure 6. If there is more than one COM port, please remember which one you are using. Make sure that the cable is connected properly. Incorrect connection of the serial cable will result in communication errors and/or incorrect communication.

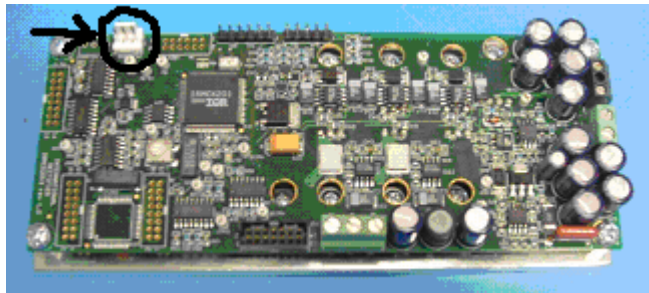

**Figure 6. Location of RS232 Connector, J4**

## 5. Software Installation

### 5.1 Installing from the CD

The distributed CD contains all necessary documents and software files. Load the CD into the CD-ROM drive on your PC and double-click “IRMCS2013.exe”. It will ask you for a password, which is in the file “iMOTION Install IRMCS2013.pdf”. After you enter the password, an automated procedure will install all necessary software on your PC. The default location for the installation is “C:\Program Files\iMOTION”.

### 5.2 ServoDesigner Startup

You should follow the instructions in this section the first time you use ServoDesigner to verify your installation and test the reference design. These “quick start” instructions assume that you’re using one of the supported motors listed in section 3.1. If not, you’ll need to enter motor configuration parameters before you can begin testing. Refer to “ServoDesigner User’s Guide” and “IRMCK201 Application Developer’s Guide” for more information.

#### *Step 1. RS232 Connection*

ServoDesigner communicates with the IRMCS2013 using a COM port on your PC. Before you start the application, you should attach an RS232 cable to the DB9 connector on the reference platform and connect it to an available COM port on your PC.

The first time you start ServoDesigner, a Connection dialog (shown in Figure 7) appears and presents you with a list of available COM ports on your system. Select the COM port to which you have connected the RS232 cable.

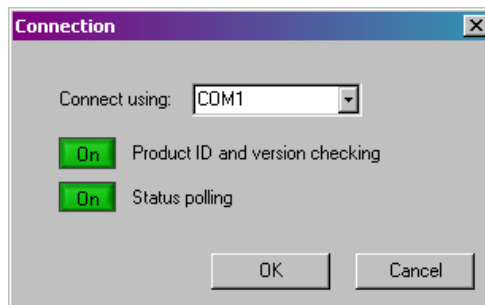

**Figure 7. The Connection Dialog**

The Connection dialog also allows you to enable and disable product ID and version checking and status polling. **You should have “Product ID and version checking” disabled and “Status polling” enabled!**

When you click OK in the Connection dialog, your selections are saved so they can be used next time you start the application. (The dialog won’t appear on startup again.) If you want to change your selections later on, you can access the Connection dialog through the Preferences menu.

The currently configured COM port is shown on the status bar at the bottom of ServoDesigner’s main display.

#### *Step 2. Numeric Format*

The first time you start ServoDesigner, the Numeric Display Format dialog appears, as shown in Figure 8. This dialog allows you to select either decimal or hexadecimal format for numeric display. Click the blue button to switch between hexadecimal and decimal. When you click OK, your setting is saved so it can be used next time you run ServoDesigner. (The dialog won’t appear on startup again.) If you want to change the setting later on, you can access the Numeric Display Format dialog through the Preferences menu.

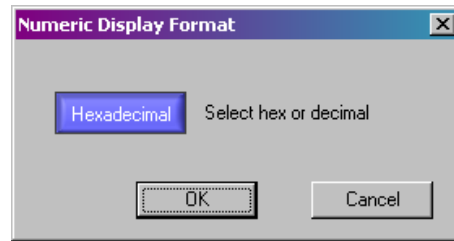

**Figure 8. The Numeric Display Format Dialog**

**Note:** Regardless of which display option you choose, you can always enter values in decimal or hexadecimal. ServoDesigner interprets a value you enter as hexadecimal if it begins with “0x” (0x222), and otherwise as decimal (222).

## 6. Running the System

### 6.1 Power-On

Apply DC 48V power to the system. Immediately after power-on, the red LED (surface mount LED D17 located close to the IRMCK201) will lit on/off indicating the on-board DC bus has been established.

### 6.2 Running motor with ServoDesigner

#### Step 1. Opening the Configuration File

You need to open a configuration file. The configuration file contains the register, functional and monitor definitions that make up ServoDesigner’s tree view. To start, you should open one of the default files that are shipped with the release. Later, when you’ve modified the register values, function definitions and/or tunable parameters, you’ll want to save your custom configuration in another file.

A default configuration file for each supported motor is shipped with the release. The file names include the part number of your product and the part number of the motor, with the file extension “.irc”. For example, one of the configuration files for the IRMCS2013 product is named “IRMCS2013- P50B05007AXS7Z ”. The files are located in the `iMOTION\ServoDesigner` directory. To open a configuration file, select Open from the File menu or click the toolbar button that shows an open folder. Browse for the file you want and click OK. An example is shown in Figure 9.

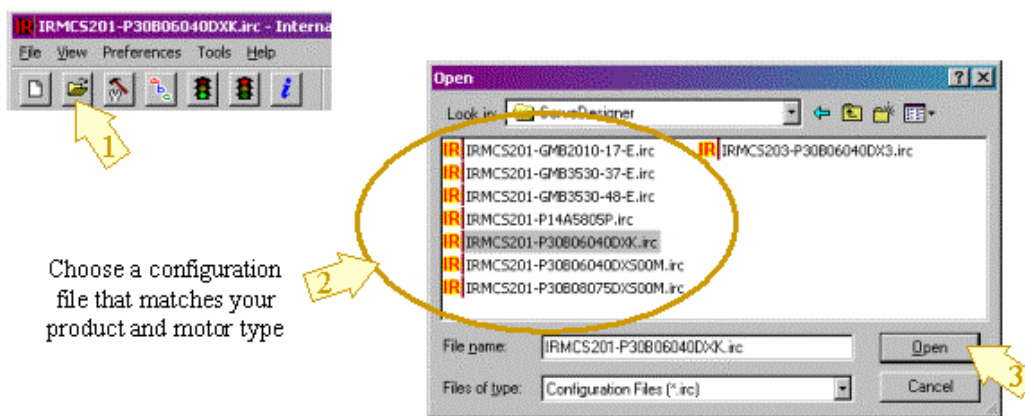
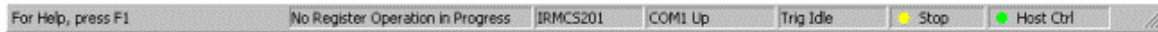

**Figure 9. Open a Configuration File**

**Note:** Configuration files are saved in text format, but you should not edit the files manually. If you need to make changes to a configuration file, open the file in ServoDesigner, make the changes as described later in this document, and then save the changes by selecting Save or Save As... from the File menu.

#### Step 2. Checking Communication Status

Until you open a configuration file, the COM port status at the bottom of ServoDesigner’s main display shows “Inactive”. When you open a file, ServoDesigner attempts to establish contact with the IRMCS2013 by executing a read operation. If ServoDesigner receives a reply to its request, the COM port status shows “Up.” If no reply is received, the status changes to “Down.” A “Down” status usually means the reference platform is not powered on, the RS232 cable is not connected, or the cable is connected to the wrong COM port. Figure 10 shows how communication status should appear before you continue your testing .



Check to be sure COM status is “Up”

**Figure 10. Communication Status Indicator**

**Note:** If you disable status polling in the Connection dialog, ServoDesigner does not attempt to establish contact with the reference platform, and the COM port status shows “Inactive” even after you open a configuration file.

### Step 3. Motor Configuration

The Configure Motor function is one of the pre-defined operations in ServoDesigner’s Function Definitions section. This function initializes the host registers for normal operation. If you click the Configure Motor entry in the tree view, a list of the registers that are written when this operation is executed is displayed in the right pane of the main window. The “Value to Write” column shows the value that will be written to each register. You can click the “+” symbol to the left of the Configure Motor function to access detailed information about each of the registers.



To execute the Configure Motor function, click the Configure Motor toolbar button (the icon shows a hammer and wrench) or double-click on the Configure Motor entry in the tree view.

Once this function is executed correctly, the LED will turn to blinking green.

### Step 4. Starting Angle

For induction motor operation, skip this step. This function reads the Hall A, B, C inputs and uses the motor magnet position data read from your configuration file to determine the starting position of the motor. (See “ServoDesigner User’s Guide” for more information about motor configuration parameters.)



To execute the function, click the Starting Angle toolbar button (the icon shows the characters “ABC”) or double-click the Starting Angle entry in the tree view.

### Step 5. Running the Motor

Start Motor and Stop Motor functions are also pre-defined Function Definitions.



To start the motor, click the Start Motor toolbar button (the green traffic signal) or double-click the Start Motor entry in the tree view.



To stop the motor, click the Stop Motor toolbar button (the red traffic signal) or double-click the Stop Motor entry in the tree view.

When the motor is running, the far right hand status bar pane should show drive status “Run” with a green indicator. When the motor is stopped, the drive status should be “Stop” with a yellow indicator. If a drive fault occurs, the status changes to “Fault” with a red indicator. The status is “Inactive” (blue indicator) when the COM port status is “Down” or “Inactive.”

### Step 6. Reference Speed

ServoDesigner provides a special built-in function that allows you to easily control the motor’s reference speed and direction. To modify the settings, see Figure 11. First, locate the Reference Speed entry in the Function Definitions section of the tree view. Right-click on the entry and select Properties. In the Properties dialog, you can enter the desired speed in RPM and the direction (forward or reverse). In the dialog, you can also specify the host register to which the speed/direction setting is written. You should not modify this setting unless you redefine the host register map.

After entering a speed and selecting forward or reverse, click OK in the dialog and then double-click the Reference Speed entry in the tree view to execute the operation. ServoDesigner calculates the appropriate value to be written the host register (based on your specified speed and direction) and performs the write operation.

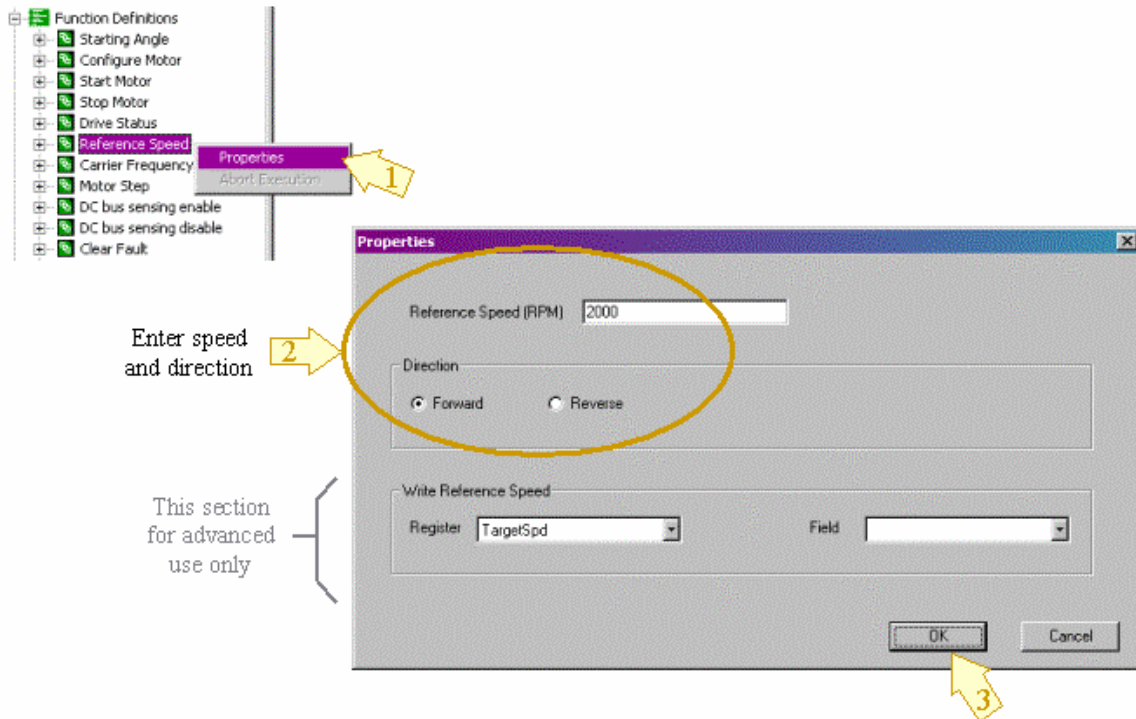

**Figure 11. Setup for Reference Speed Function**

### Step 7. Drive Status

The Info button on the toolbar (letter “i”) executes the pre-defined Drive Status function, which reads a group of host registers associated with the function.

 To get drive status, click the Info button or double-click the Drive Status entry in the tree view. After you’ve executed the function, click on Drive Status in the tree view (if it’s not already selected). In the right pane of the main window, the values read from the Drive Status registers are shown in the Current Value column.



## 7. Motion Control Engine

### 7.1 Motion Control Engine (MCE) Based Complete Servo Control

Figure 12 shows the detailed algorithm block diagram including various parameters which can be configured through the host register interface.

Closed loop current and velocity control are implemented in the IRMCK201 IC on the IRMCS2013 board. The closed loop current control algorithm is based on a synchronously rotating frame. The velocity control is available as an outer loop control of the current control and can be disabled in order to configure torque control mode. Additional configuration allows feedforward control, selection of the position feedback devices, induction machine vector control, and selection of communication protocol.

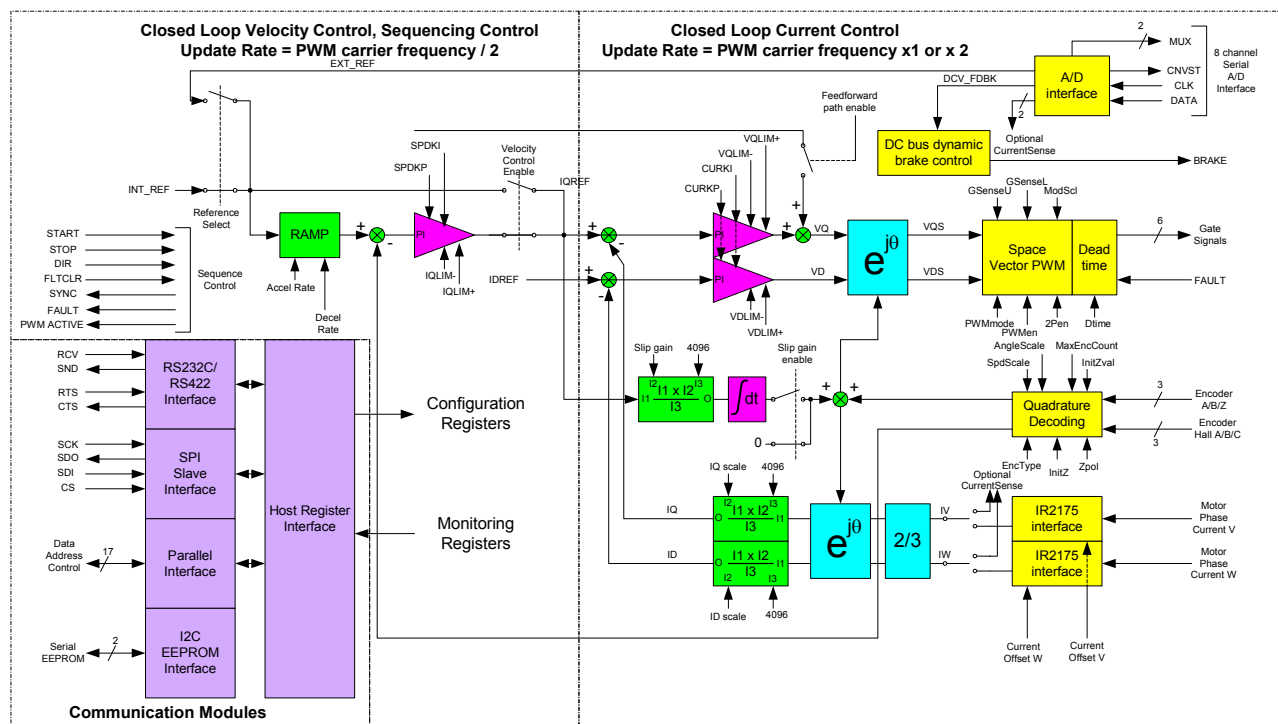

Figure 12. IRMCK201 Based Complete Servo Control



## 8. New Motor Adaptation

New motor can be configured by simple EXCEL spreadsheet. EXCEL spreadsheet template is provided in the shipment with the filename “IRMCS201-DriveParams.xls”.

This spreadsheet facilitates configuration of parameters which need to go into each host registers inside of the IRMCK201 IC. The spreadsheet calculates current feedback/speed feedback scaling, Proportional plus Integral (PI) gains of current and speed regulators, PWM carrier frequency, deadtime, etc, based on simple motor nameplate and published data input. The output of this spreadsheet is text file containing one-to-one corresponding each registers' values. User can use the ServoDesigner™ to read this output into the associated registers.

For detailed operation, please refer to “3.1 Drive Parameter Setup” in IRMCK201 Application Developer’s Guide.

Motor Selection :  **P30B06040DXS00M**  
(Type the number here!) password : 201

===== **Motor Information** =====

(RPM) Rated Speed	<b>3000rpm</b>	
(Lq) L_phase	<b>0.00644H</b>	(line to line Inductance) / 2
(R_Stator) R_phase	<b>1.4ohms/ph</b>	(line to line Resistor) / 2
(Amps) Rated Amps	<b>2.7Arms</b>	
(NLC)No Load Current	<b>0Arms</b>	(necessary for IM)
(Jm) Inertia of Motor	<b>2.55E-05Kg-m2</b>	
(Kt) Torque Constant	<b>0.533N-m/Arms</b>	
(Ke) Voltage Constant	<b>18.6V In-rms/krpm</b>	voltage is line to neutral rms
Poles	<b>8</b>	
(PPR) Encoder PPR	<b>2000pulse/revolution</b>	
Wire-Saving Encoder?	<b>TRUE( TRUE / FALSE )</b>	

===== **Application Information** =====

----- **General** -----

Max RPM	<b>4500rpm</b>
(Vdc_Nom) Nominal Vdc	<b>310Volts</b>
(OvLoad) Max pu motor current at rated speed	<b>3pu</b>

----- **Speed Regulator Tuning** -----

Speed Regulator BW	<b>200rad/sec</b>
Positive Speed Rate limit	<b>1000rpm/sec</b>
Negative Speed Rate limit	<b>1000sec to rate speed</b>
Inertia of Load (measured)	<b>0Kg-m2</b>
SpdLpRate	<b>21 SpdLoop per this # of CurLoop</b>

----- **Current Limits** -----

Motoring Limit	<b>200%</b>
Regen Limit	<b>200%</b>



<b>"----- Inverter Switching Frequency -----"</b>	
(fc) Pwm carrier freq	<b>10KHz</b>
Dead_Time	<b>0.5usec</b>
<b>" ----- Current Regulator Tuning ----- "</b>	
(Ireg_BW) Current Reg BW	<b>2500rad/sec</b>
<b>"===== Advance Information (Platform fixed) ====="</b>	
<b>Note:</b> Below values are fixed for IRMCS2013 platform however can be changed for other platform	
(Clk) IRMCK201 clock freq	<b>33.333MHz</b>
DC Bus Scaling (Vdc_Scl)	<b>8.1875cts/Volt</b>
I_Torque (I_Trq_Rated)	<b>4095cts for rated Amps</b>
(Mod_Pk) - U_Alpha U_Beta max linear modulation	<b>2355Cts</b>
<b>" ----- Desired Speed feedback Scaling -----"</b>	
(Spd_Scale)	<b>16384cts/(Max RPM)</b>
<b>" ----- Current Feedback Scaling -----"</b>	
Current Shunt Resistor	<b>10mOhm</b>
Max H/W Current	<b>26Apeak</b>
<b>"===== Commutation Information ====="</b>	
Angle of Z-pulse (based on UV line to line voltage)	<b>272degree</b>
Mid Angle when Hall CBA is 001	<b>120degree</b>
Mid Angle when Hall CBA is 010	<b>240degree</b>
Mid Angle when Hall CBA is 011	<b>180degree</b>
Mid Angle when Hall CBA is 100	<b>0degree</b>
Mid Angle when Hall CBA is 101	<b>60degree</b>
Mid Angle when Hall CBA is 110	<b>300degree</b>

**Figure 13. EXCEL Spreadsheet Inputs**

## 9. Appendix

### 9.1 External I/O

Connect External I/O Connector (J7) as needed. All inputs are 5V tolerant and high true logic.

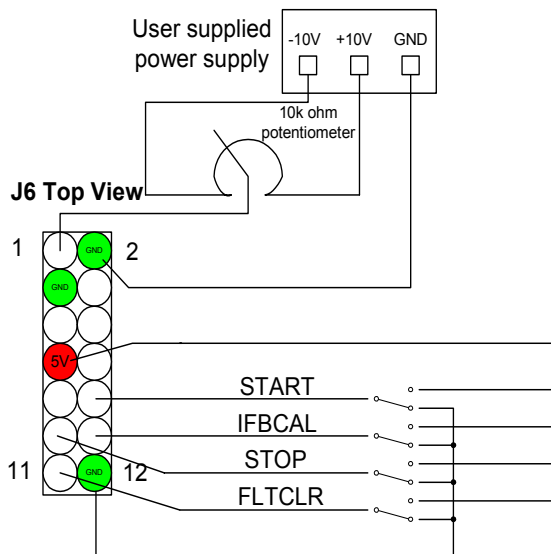

#### Pin definition

- Pin 1: Analog input (+/-10V)
- Pin 2: Analog GND
- Pin 3: Digital GND
- Pin 4: FAULT status output (3.3V when FAULT)
- Pin 5: SYNC status output (3usec width of active low pulse at every carrier frequency period)
- Pin 6: PWMACTIVE output (3.3V when PWM active)
- Pin 7: +5V
- Pin 8: START input (high to activate)
- Pin 9: STOP input (high to activate)
- Pin 10: Ifb offset calibration input (high to activate)
- Pin 11: Fault Clear input (high to activate)
- Pin 12: Digital GND

**Figure 14. External I/O Connector, J6**

### 9.2 RS232C Connector

IRMCS2013 has two serial RS232C connectors on the board. J4 is for IRMCK201 and J5 is for Microchip IC (U19). Adaptation from D-sub 9 pin standard PC female connector to AMP 3 pin connector are required to be directly connectable to PC serial port. As shown in Figure 15, pin 1 is send-signal and pin 2 is receive-signal, and both are 10V signal level. The baud rate is fixed at 57.6 kbps. The signal format is 8 bits, no parity, 1 stop bit.

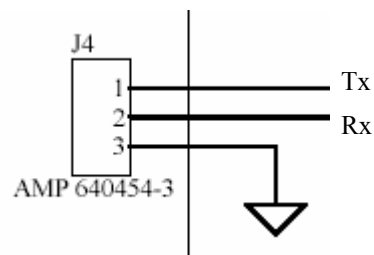
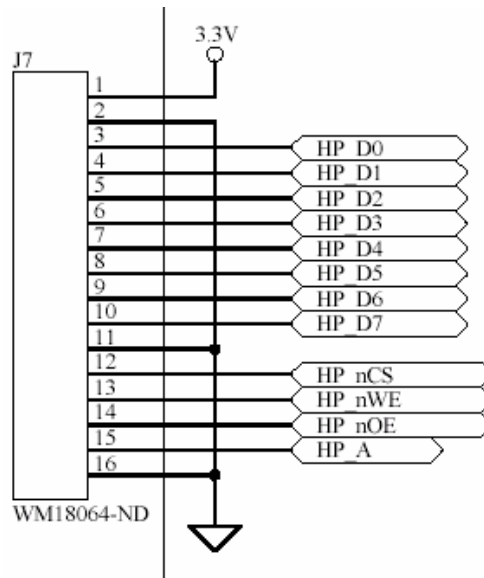

**Figure 15. RS232C Connector, J4**

## 9.3 Parallel Interface Port

IRMCS2013 provides an 8-bit parallel interface port to facilitate microprocessor interface. The interface is generic and compatible with most common 8-bit parallel interfaces such as MCS8051, some Motorola 8-bit uP, MicroChip, etc.

Figure 16 shows the connection diagram. The connector J7 is a 2-by-8 connector.



**Figure 16. Parallel Interface Port, J7**

Each signal is 3.3V level and data bus is multiplexed. Table 3 summarizes each signal definition.

Signal	I/O <sup>1</sup>	Description
HP_nCS	I	Active low Host Port Chip Select
HP_nOE	I	Active Low Host Port Output Enable
HP_nWE	I	Active low Host Port Write Enable
HP_A	I	Host Port Register Address. 1 = Address register, 0 = Data Register
HP_Dn	I/O	Bidirectional Host Port data bus, where $n = \text{data bit } 0 - 7$

**Table 3. Microprocessor Interface Module Signal Definitions**

Figure 17 and Table 4 show read cycle timing for the host parallel interface. Figure 18 and Table 5 show write cycle timing.

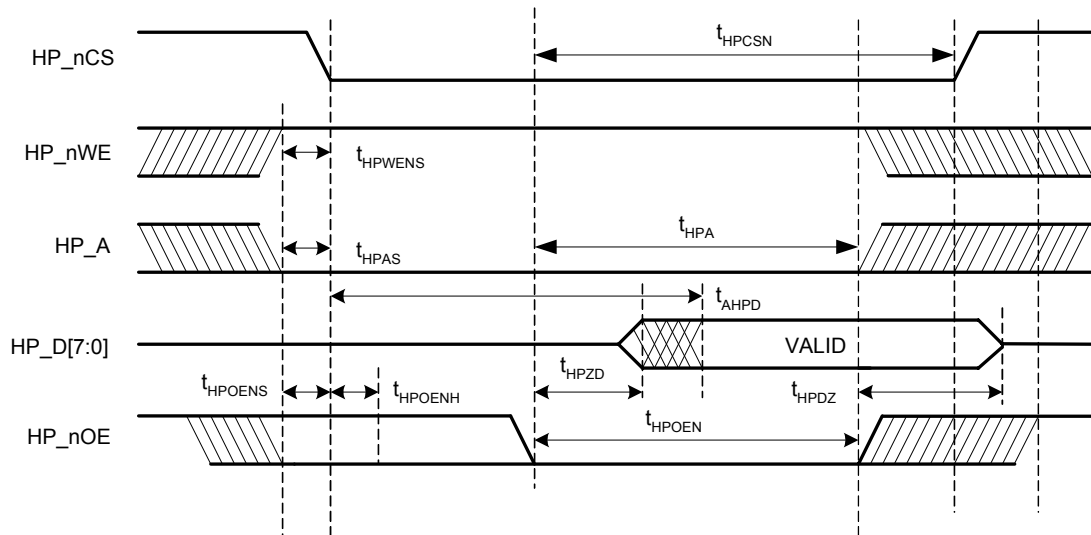

Figure 17. Host Parallel Read Cycle Timing

SYMBOL	DESCRIPTION	MIN	MAX	UNIT	NOTE
$t_{HPCSN}$	HP_nCS Period	70		ns	
$t_{HPWEENS}$	HP_nWE Setup	10		ns	
$t_{HPAS}$	HP_A Setup	10		ns	
$t_{AHPD}$	HP_D [7:0] Access	60	105	ns	
$t_{HPZD}$	HP_D [7:0] Active	0	9	ns	
$t_{HPDZ}$	HP_D [7:0] High Impedance	0	6	ns	
$t_{HPOENH}$	HP_nOE Hold	10		ns	Note 3
$t_{HPOENS}$	HP_nOE Setup	10		ns	Note 3
$t_{HPOEN}$	HP_nOE Period	70		ns	

Table 4. Host Parallel Read Cycle Timing

Note3 : HP\_nOE must be stable before and after the high to low transition of HP\_nCS.

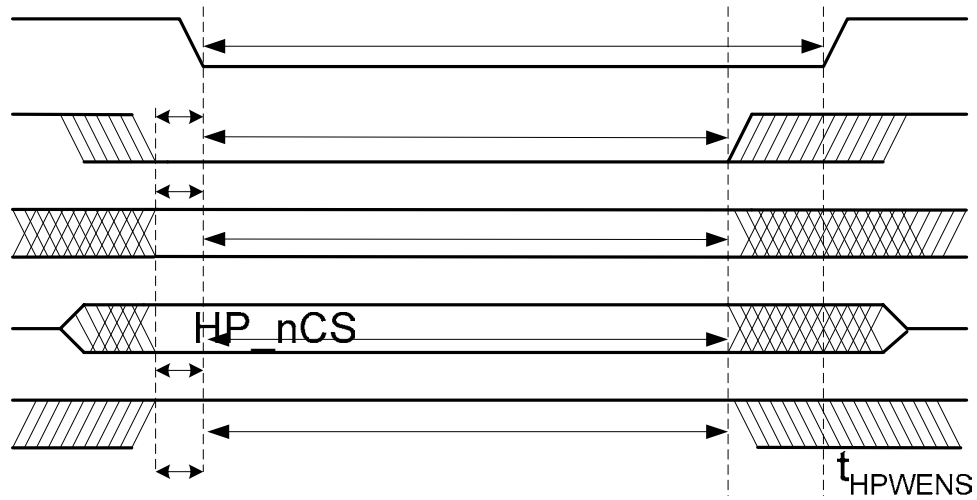

Figure 18. Host Parallel Write Cycle Timing

$t_{HPAS}$

SYMBOL	DESCRIPTION	MIN	UNITS	NOTE
$t_{HPCSN}$	HP_nCS Period	70	ns	
$t_{HPWENS}$	HP_nWE Setup	10	ns	
$t_{HPWEN}$	HP_nWE Period	70	ns	
$t_{HPAS}$	HP_A Setup	-10	ns	
$t_{HPA}$	HP_A Period	70	ns	
$t_{HPD[7:0]}$	HP_D[7:0] Setup	-10	ns	
$t_{HPOENS}$	HP_nOE Setup	10	ns	
$t_{HPOEN}$	HP_nOE Period	70	ns	Note 4

Table 5. Host Parallel Write Cycle Timing

HP\_nOE

Note 4: HP\_nOE must be asserted high while HP\_nCS low during a Host Parallel Write Cycle.

$t_{HPOENS}$

## 9.4 SPI Port

IRMCS2013 provides an SPI port to facilitate microprocessor interface. It works only as a slave. The connector, J10, is a 1-by-6 header connector.

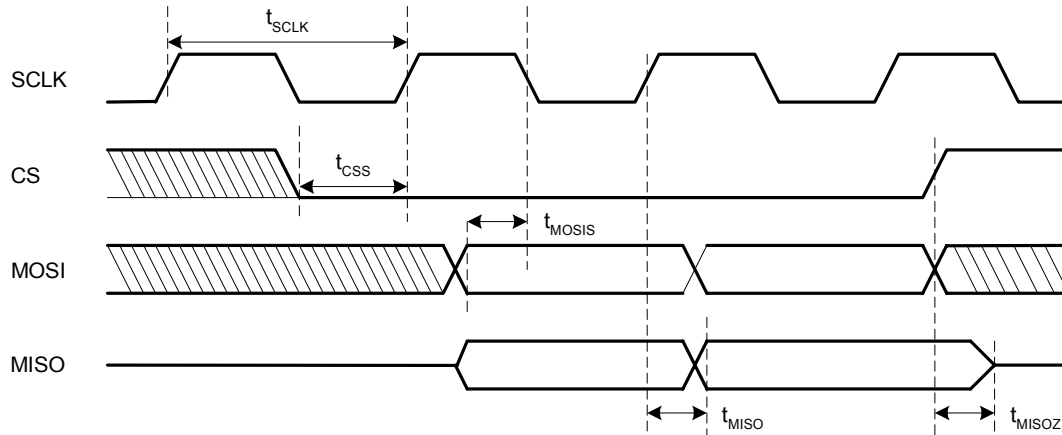

**Figure 19. SPI Timing**

SYMBOL	DESCRIPTION	MIN	MAX	UNITS
$f_{SCLK}$	ADC Clock Frequency		8	MHz
$t_{SCLK}$	ADC Clock Period	125		ns
$t_{CSS}$	CS to SCLK high Setup	20		ns
$t_{MOSIS}$	MOSI to SCLK low Setup	20		ns
$t_{MISO}$	SCLK to MISO Valid	72		ns
$t_{MIOZ}$	CS to MISO High Impedance	15	35	ns

**Table 6. SPI Timing**





## 10. Specifications

T<sub>c</sub>=25°C unless specified

Parameters	Values	Conditions
<b>Input Power</b>		
Voltage	22 to 50V	T <sub>A</sub> =40°C, R <sub>thSA</sub> =1.0 °C/W
Input current	6.1A rms @nominal output	
Input line impedance	4%~8% recommended	
<b>Output Power</b>		
Watt	350W continuous power	V <sub>in</sub> =48V DC, f <sub>PWM</sub> =20kHz, f <sub>O</sub> =60Hz, T <sub>A</sub> =40°C, R <sub>thSA</sub> =1.0 °C/W
Current	6.0 Arms nominal, 18 Arms Overload	3 secs overload
<b>Host interface (SPI)</b>		
SCLK,CS,MISO,MOSI, SYNC	3.3V logic level	Isolated, maximum 6MHz
<b>Host interface (RS232C)</b>		
Tx, Rx	10V	Maximum 57.6k bps, single ended, configurable for RS422 up to 1Mbps
<b>Host interface (Parallel Port)</b>		
HP_nCS, HP_nOE, HP_nWE, HP_A, HP_DATA[8]	3.3V	8 bit parallel interface compatible with 8051, MicroChip, other μP.
<b>D/A</b>		
8 bit 4 Channel	0-3.3V output	Output is buffered with 4mA drive capability
<b>A/D</b>		
12 bit 2 channel	±10V for reference input, 5V for DC bus input	
<b>Discrete I/O</b>		
Input	4 bit, START, STOP, FLTCLR, IFBCAL	5V tolerant, Isolated, Active High logic
Output	3 bit, PWMACTIVE, FAULT, SYNC	
<b>Current feedback</b>		
Current sensing device	IR2175, direct interface	133 MHz internal IRMCK201 clock
Resolution	10 bit (7.5 nanoseconds counting resolution)	
Latency	8.3 usec	
<b>Protection</b>		
Output current trip level	28A peak, ±10%	All differential signals are converted to single ended signals including index pulse
Ground fault trip level	28A peak, ±10%	
Over-voltage trip level	63.3V	
Under-voltage trip level	18.4	
<b>Dynamic Brake voltage</b>		
DB turn-on voltage	58.7V	Bootstrap power supply for high side circuit
DB turn-off voltage	55.6V	
<b>Encoder Interface</b>		
Incremental encoder	Maximum 2 MHz	All differential signals are converted to single ended signals including index pulse
Hall A/B/C initialization	Programmable wire saving/dedicated A/B/C	
<b>Power Devices</b>		
IRFB59N10D + IR2106	6 MOSFETs + 3 gate drivers	Bootstrap power supply for high side circuit
<b>System environment</b>		
Ambient temperature	0 to 40°C	95%RH max. (non-condensing)

Table 7. IRMCS2013 Electrical Specification



# Reference Design IRMCS2013

International  
**IOR** Rectifier

IR WORLD HEADQUARTERS: 233 Kansas St., El Segundo, California 90245, Tel: (310) 252-7105  
<http://www.irf.com> *Data and specifications subject to change without notice.*

*Sales Offices, Agents and Distributors in Major Cities Throughout the World.*