

LOC		DIST		REVISIONS			
P	LTR	DESCRIPTION	DATE	DWN	APVD		
A		INITIAL	01JUN2006	RAH	RAH		

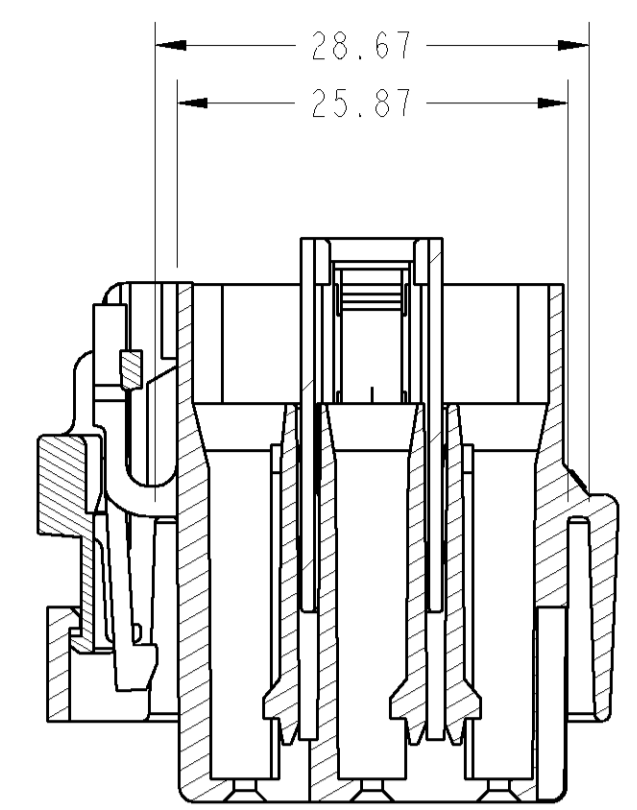

SECTION D-D

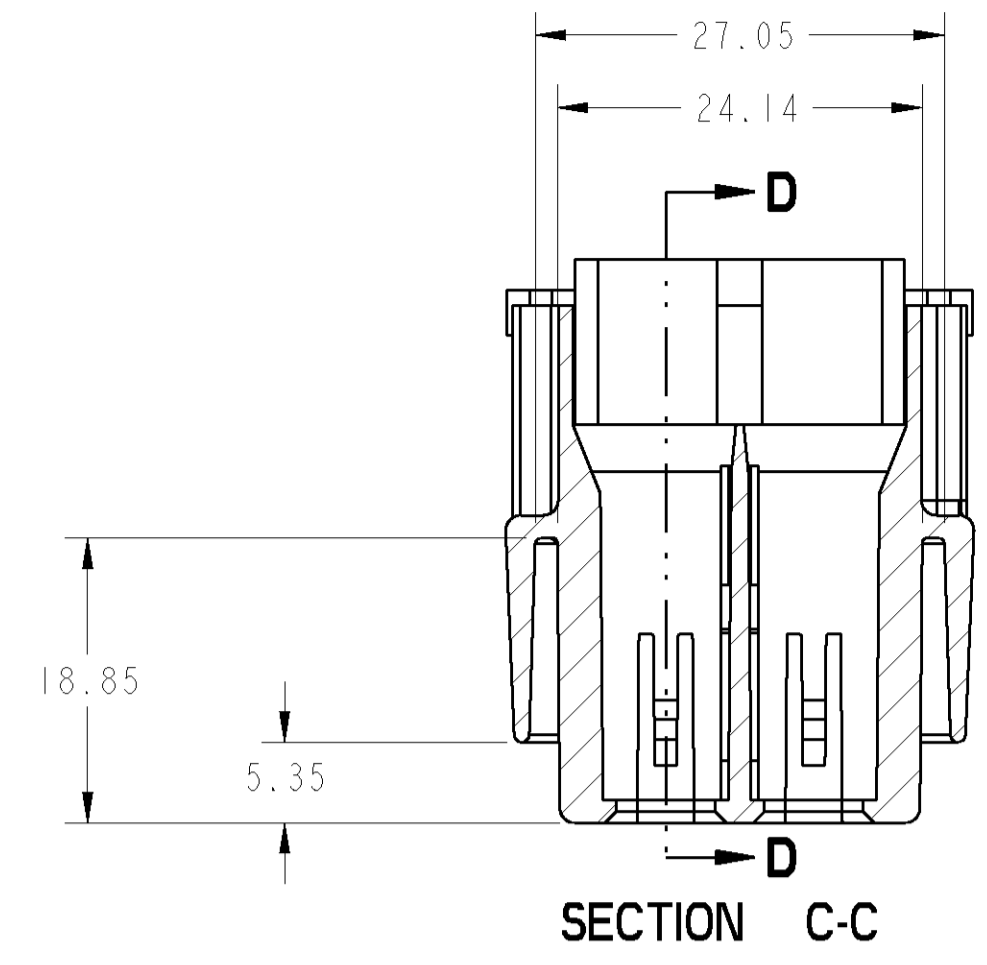

SECTION C-C

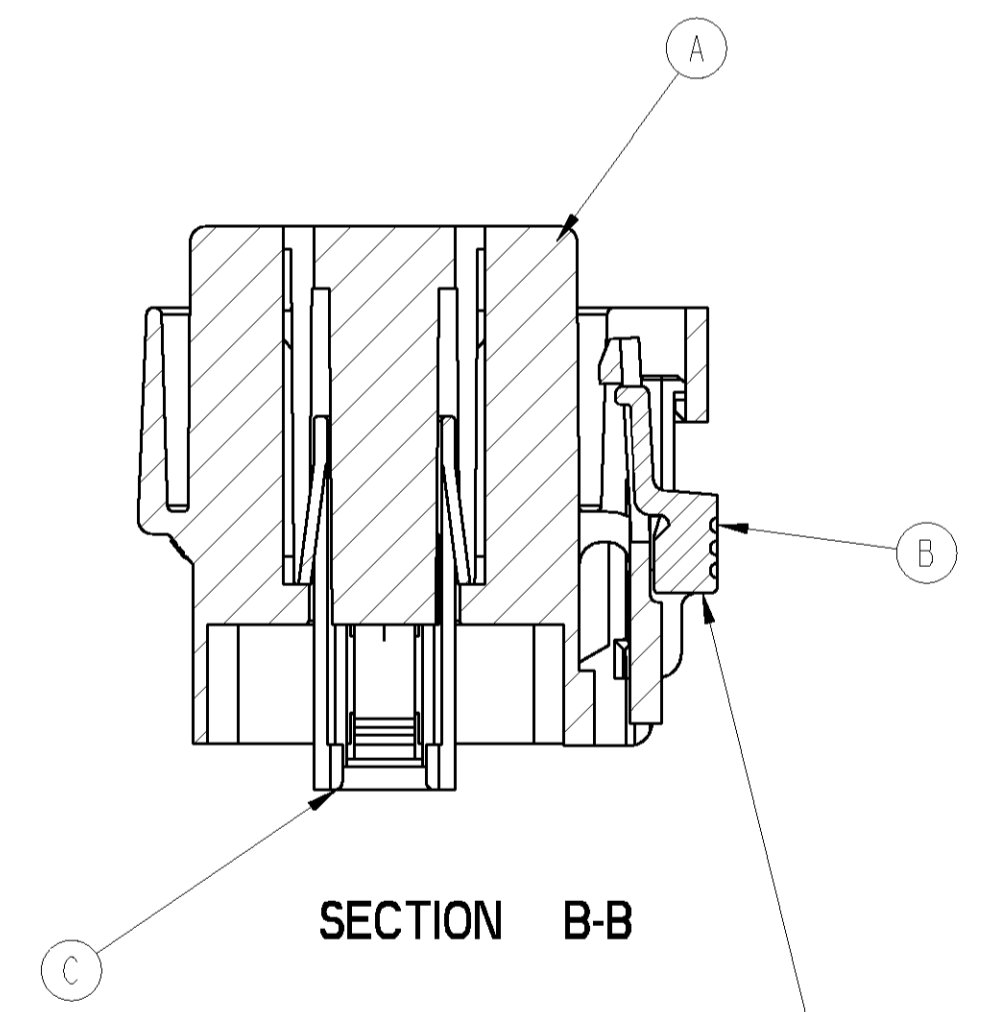
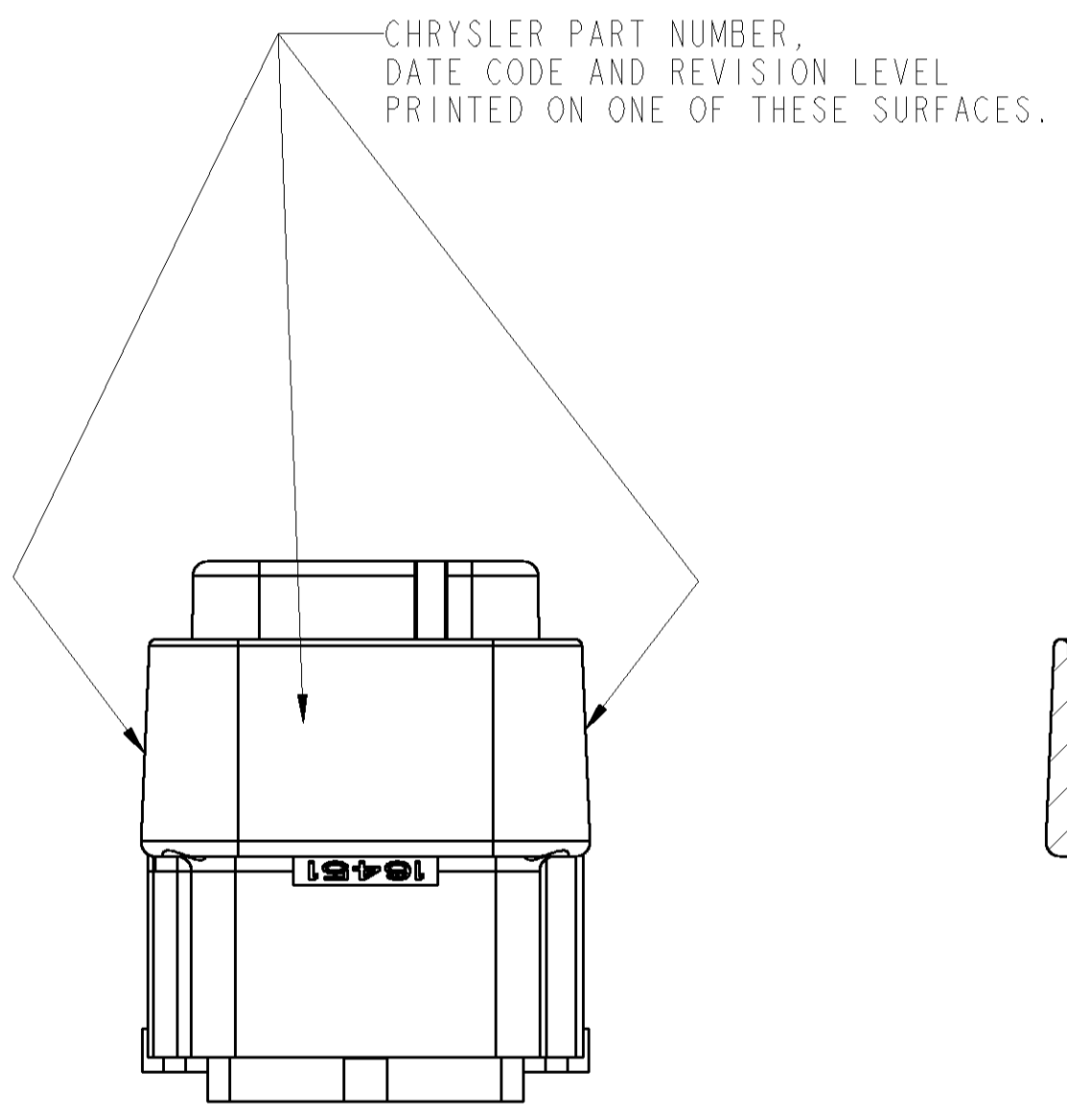
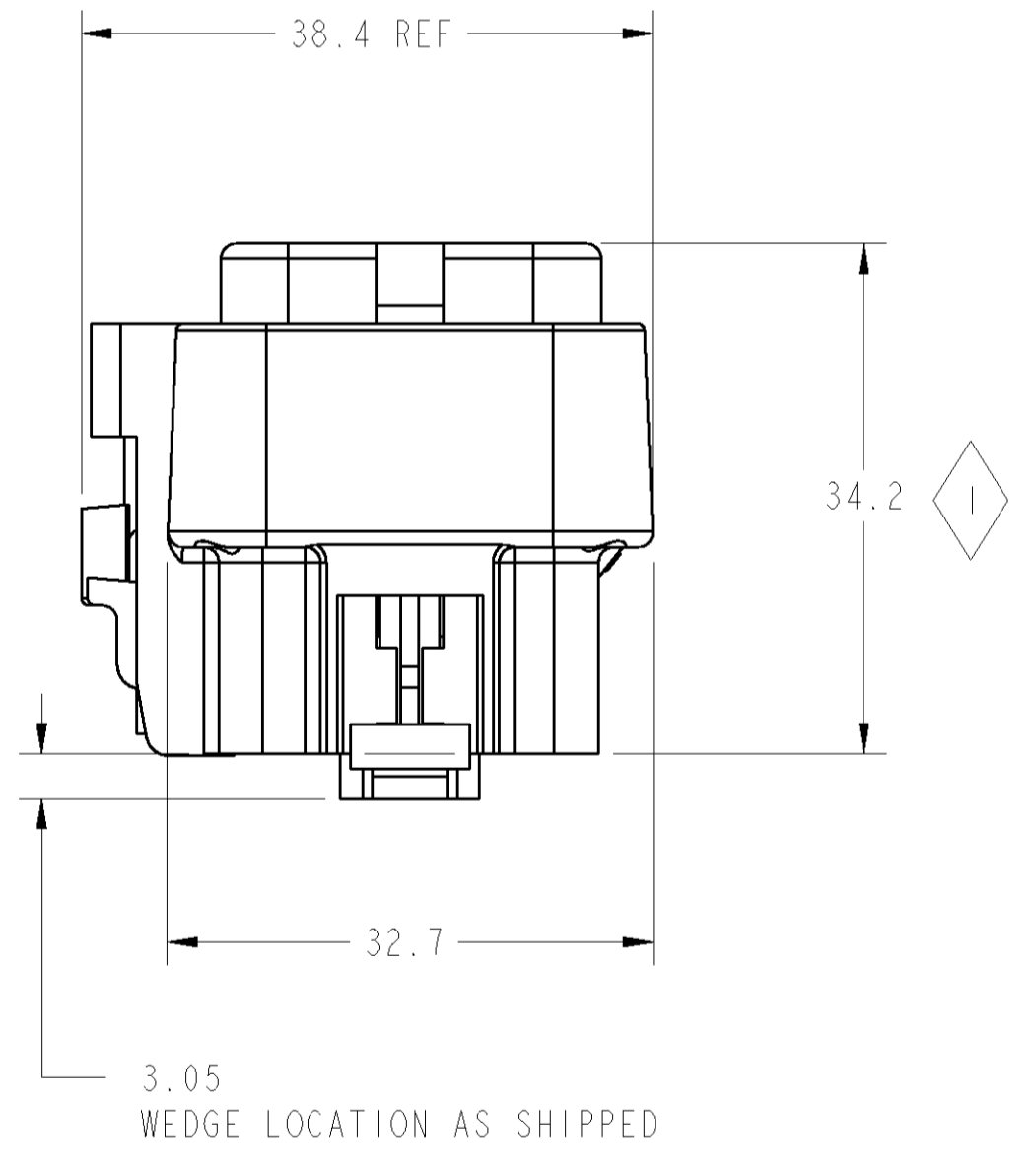
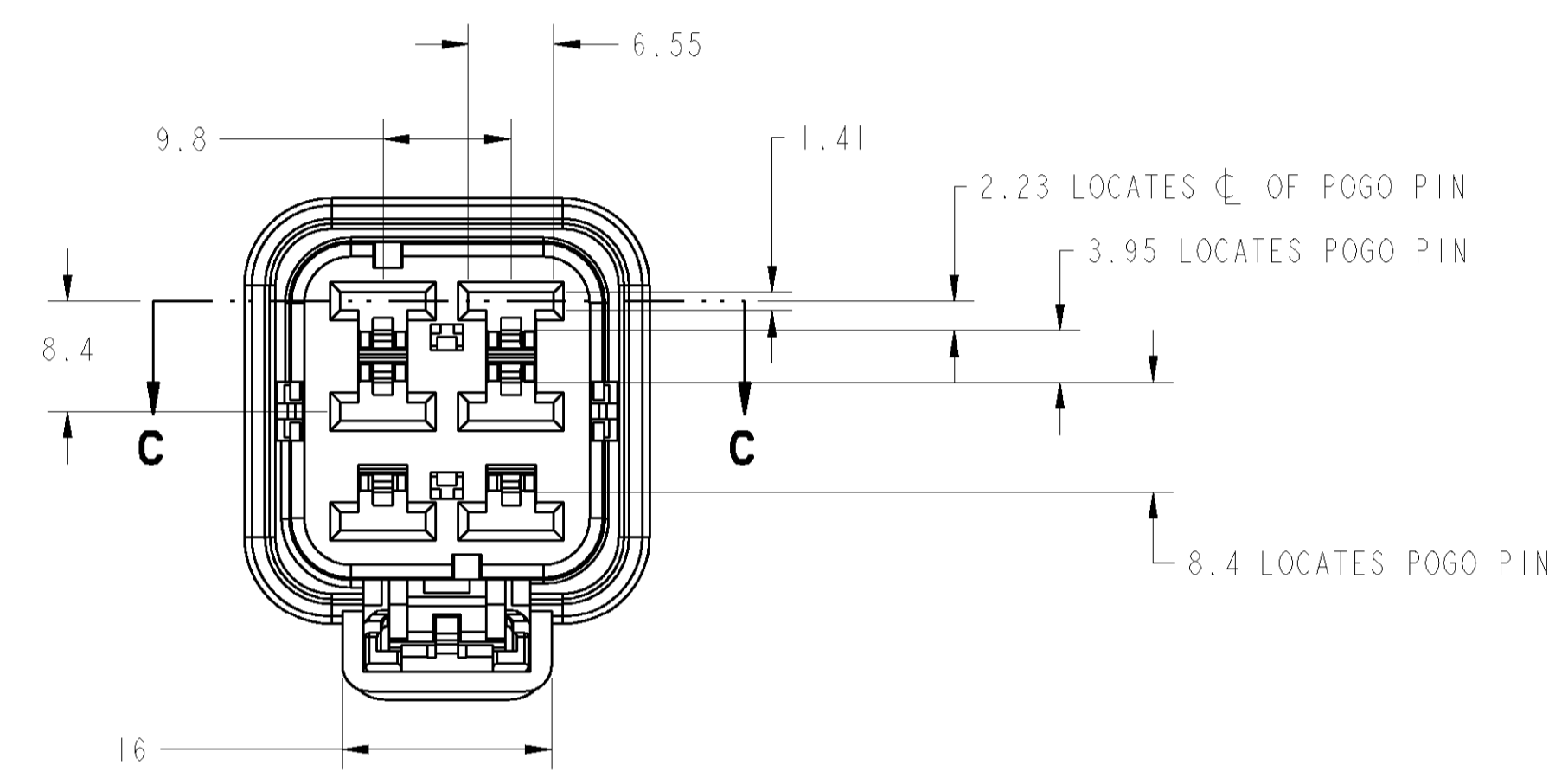
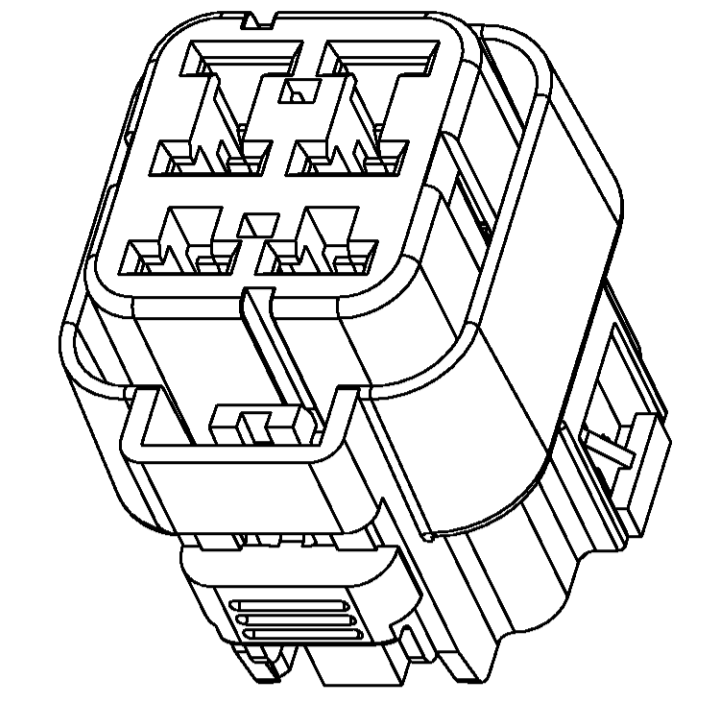

SECTION B-B

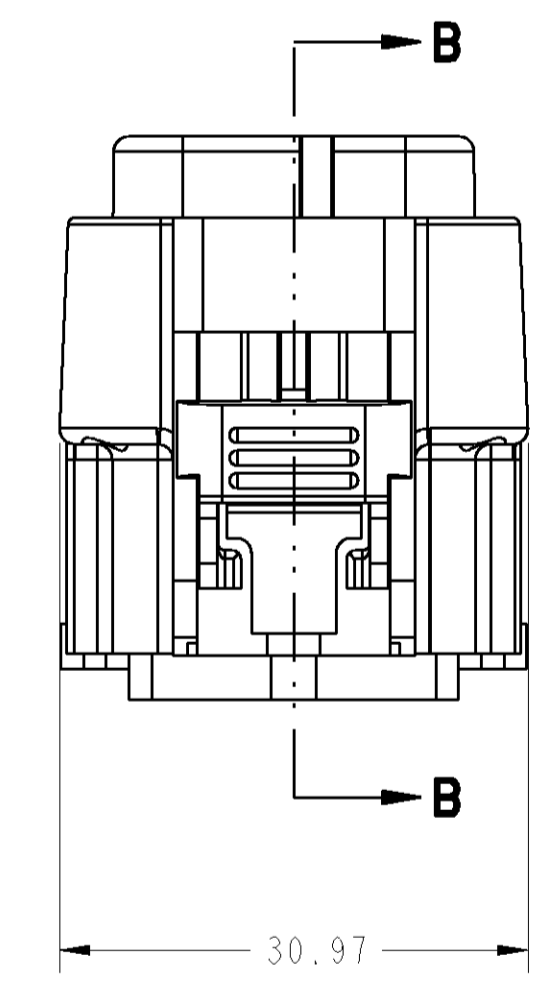

SEAT CPA AFTER CONNECTOR HAS BEEN ASSEMBLED TO HEADER

PRESS HERE AND INSERT WEDGE TO LOCKED POSITION AFTER TERMINALS ARE IN PLACE

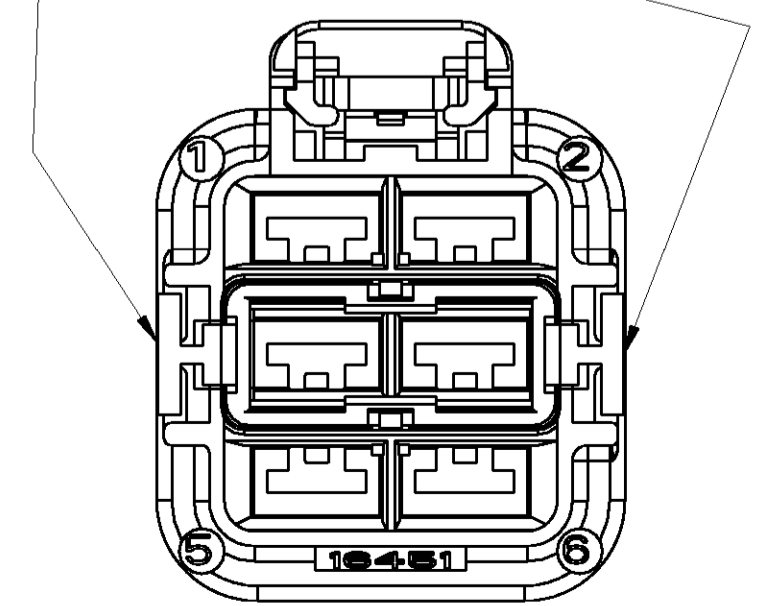

ITEM	AMOUNT REQUIRED	DESCRIPTION
A	1	HOUSING
B	1	CPA
C	1	WEDGE

PRINT CONTROLLED BY DAIMLERCHRYSLER
 CHANGES MUST BE SUBMITTED TO
 DAIMLERCHRYSLER ENGINEERING FOR APPROVAL
 FOR DAIMLERCHRYSLER CATIA COMMENT
 PAGE INFORMATION, SEE SHEET 2

DIMENSIONS:		TOLERANCES UNLESS OTHERWISE SPECIFIED:		OWN	01JUN2006	tyco Electronics	Tyco Electronics Harrisburg, PA 17105-3608
mm		0 PLC ±0.3 1 PLC ±0.3 2 PLC ±0.3 3 PLC ±0.3 4 PLC ±0.3 ANGLES ±1		CHK	01JUN2006		
MATERIAL		FINISH		APVD	01JUN2006	NAME	
SEE NOTES PAGE 2		SEE NOTES		JKM		CONNECTOR ASSY-BODY CONTROL MODULE (D)	
				PRODUCT SPEC		SIZE	
				APPLICATION SPEC		CAGE CODE	
				SEE NOTES		DRAWING NO	
				WEIGHT		RESTRICTED TO	
				CUSTOMER DRAWING		A 00779 C-5-1437866-4	
				SCALE		SHEET 1 OF 2	
				NONE		REV A	

LOC	DIST	REVISIONS					
		P	LTR	DESCRIPTION	DATE	DWN	APVD
HK	00	-	-	SEE SHEET 1	-	-	-

PART NO: 04868084AA MODEL: 1 OF 1
 TITLE: CONNECTOR ASSY - BODY CONTROL MODULE (D)
 LAST CHANGE: C STANDARD UNIT: MM
 YR-MOD: 2001/RS DESIGN RESP: TYCO
 UPG CODE: 79E0ID DEPT NO: 9730
 VSC: 36510 DEPT NAME: NS/RS POWER DIST. SYSTEMS
 DESIGNER: K.DEKOSKI CHECKER: K.DEKOSKI
 ENGINEER: D. LESCAMELA SENIOR ENG.: S. MASON
 PHONE NO.: 248-576-4392 DATE STARTED: 4-28-98

REVISION RECORD

AUTHORITY ! DSNR! ENG ! CHK ! SUPV! GDT ! PLP ! WELD! DATE
 !CHG!ZONE!SHT!REVISION RECORD
 ! DS ! KD ! KD ! RB ! ! ! ! 01/28/99
 ! A ! ! !PRODUCTION RELEASE!
 AUTHORITY ! DSNR! ENG ! CHK ! SUPV! GDT ! PLP ! WELD! DATE
 !CHG!ZONE!SHT!REVISION RECORD
 00218-M01 ! DS ! KD ! KD ! RB ! ! ! ! 3/02/00
 ! B ! ! ! REVISED CPA
 AUTHORITY ! DSNR! ENG ! CHK ! SUPV! GDT ! PLP ! WELD! DATE
 !CHG!ZONE!SHT!REVISION RECORD
 10403-M07 ! KD ! KD ! KD ! RB ! ! ! ! 4/19/01
 ! C ! ! ! REVISED 3.05 SHIPPED LOCATION DIMENSION

STANDARDS

ITEM	NUMBER	NAME	APVD
1	PS-9227	CAD/CAM DATA EXCHANGE POLICY	!
2	PS-4480 <S>	IDENTIFICATION OF PARTS	!
3	PS-7000	(ODD BOX ITEMS)	!
4	PS-8500	GENERAL PERFORMANCE REQUIREMENTS	!
5	PS-9611	GD&T PRACTICES	!
6	PS-7300 <D>	QUALITY ASSURANCE DIAMONDS	!
7	PF-9600	USCAR PF-1 EQUIVALENT	!
8	MS-DB469	MATERIAL SPECIFICATION	!

GENERAL ENGINEERING NOTES

- ALL DIMENSIONS TO SHARP CORNERS WITH A RADIUS ARE TAKEN FROM THEORETICAL SHARP CORNERS UNLESS EXPLICITLY SHOWN OTHERWISE.
- WILL ACCEPT TERMINAL CHRYSLER P/N 4801089 AND 04801136AA

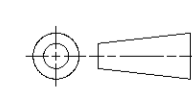
<small>THIS DRAWING IS UNPUBLISHED. RELEASED FOR PUBLICATION. IT IS THE PROPERTY OF TYCO ELECTRONICS CORPORATION. IT IS TO BE USED ONLY FOR THE PURPOSES AND ORGANIZATION SPECIFIED HEREON. IT IS NOT TO BE REPRODUCED OR TRANSMITTED IN ANY FORM OR BY ANY MEANS, ELECTRONIC OR MECHANICAL, WITHOUT THE WRITTEN PERMISSION OF TYCO ELECTRONICS CORPORATION.</small>		DWN: RAH 01 JUN 2006 ENG: JKM 01 JUN 2006 APVD: JKM 01 JUN 2006	tyco Tyco Electronics Harrisburg, PA 17105-3608
DIMENSIONS: mm 	TOLERANCES UNLESS OTHERWISE SPECIFIED: 0 PLC ±0.3 1 PLC ±0.3 2 PLC ±0.3 3 PLC ±0.3 4 PLC ±0.3 ANGLES ±1	PRODUCT SPEC: SEE NOTES APPLICATION SPEC: SEE NOTES	NAME: CONNECTOR ASSY - BODY CONTROL MODULE (D) SIZE: A 00779 C=5-1437866-4 RESTRICTED TO: -
MATERIAL: SEE NOTES PAGE 2 FINISH: SEE NOTES	WEIGHT: - CUSTOMER DRAWING	SCALE: NONE SHEET: 2 OF 2 REV: A	