



ANATECH ELECTRONICS INC
RF & Microwave Filters & Products

2106 MHz Cavity Bandpass Filter

Part Number: AE2106B10565



Electrical Specifications

Center Frequency: 2106 MHz

Bandwidth: 15 MHz

Passband ripple: 0.05dB

Impedance: 50 Ohms

Mechanical

Connector Type: SMA(Female)

Dimensions: 1.9" X 1.3" x 0.45" in.

Environmental

Operating Temperature: -25°C to +70°C

Storage Temperature: -40°C to +90°C

Shock: 20 G. 11ms

Vibration: 20 G. 5 to 200Hz

Outline Drawing:

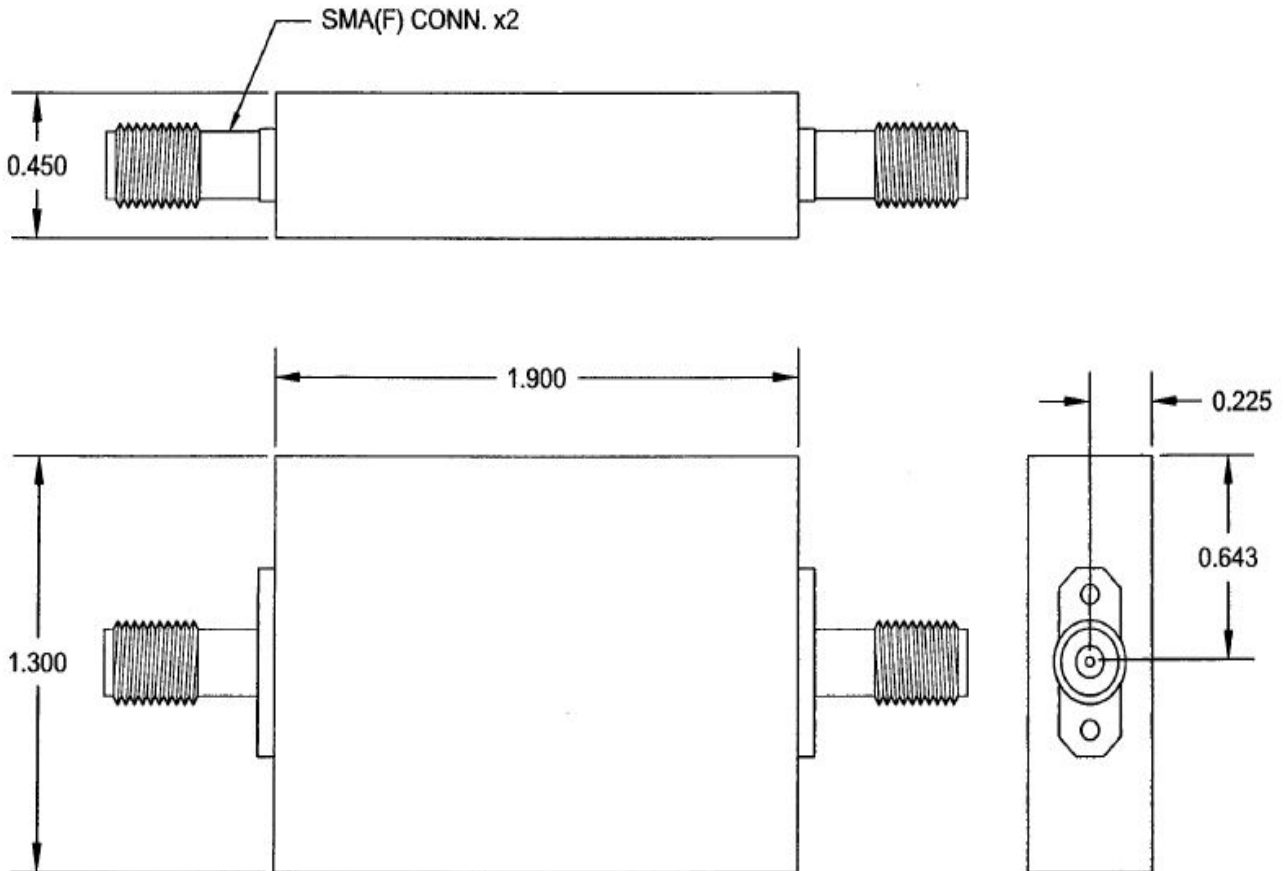



ANATECH ELECTRONICS INC
RF & Microwave Filters & Products

2106 MHz Cavity Bandpass Filter

Part Number: AE2106B10565



Response Plot:

