

1

2

3

4

5

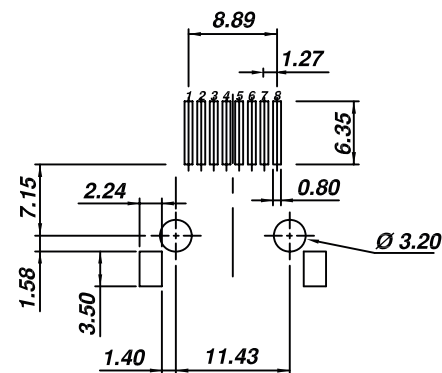
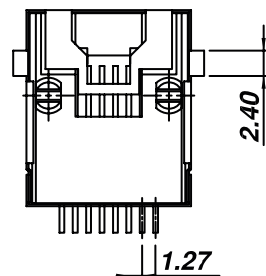

PCB LAYOUT - COMPONENT VIEW

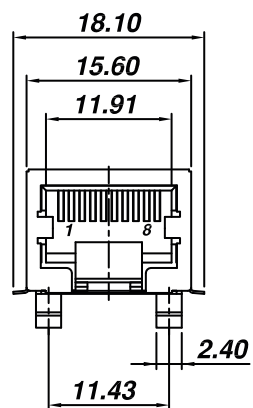
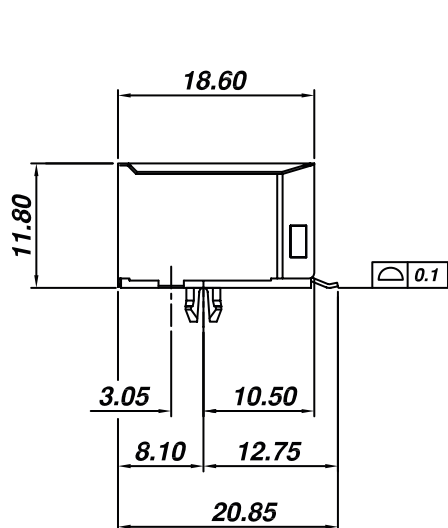

TECHNICAL CHARACTERISTICS

MATERIAL

INSULATOR: - HOUSING: PA 9T
- INSERT HOUSING: PA 46

FLAMABILITY RATING: UL94-V0
COLOR: BLACK
CONTACT MATERIAL: COPPER ALLOY
CONTACT TYPE: STAMPED
CONTACT PLATING: SELECTIVE GOLD
SHIELDING: BRASS NI PLATED
QUALITY CLASS: 500 MATING CYLCES

ENVIRONMENTAL

OPERATING TEMPERATURE: -40°C UP TO +85°C
COMPLIANCE: LEAD FREE AND ROHS

ELECTRICAL

CURRENT RATING: 1.5A
WORKING VOLTAGE: 120V AC
INSULATION RESISTANCE: >500MΩ
WITHSTANDING VOLTAGE: 1000 VAC/min
CONTACT RESISTANCE: 20mΩ max

STANDARD

 CERTIFIED: E324776

SOLDERING

JEDEC LEAD FREE REFLOW SOLDERING PROCESS

PACKAGING

TRAY

RoHS Compliant

PROJECTION:



GENERAL TOLERANCE

.X = ± 0.3 .XX = ± 0.25 

APPROVAL: RJ

UNIT: MM

SCALE:

SHEET: 1/3

DRAW: AS

DESCRIPTION: HORIZONTAL SHIELDED LOW PROFILE SMT 10P8C
TAB DOWN

WERI PART NO: 634 008 150 021

SIZE

A4

G			
F			
E			
D			
C			
B			
A	23-JUL-14	PDF	AS
REV	DATE	FILE	BY

1

2

3

4

5

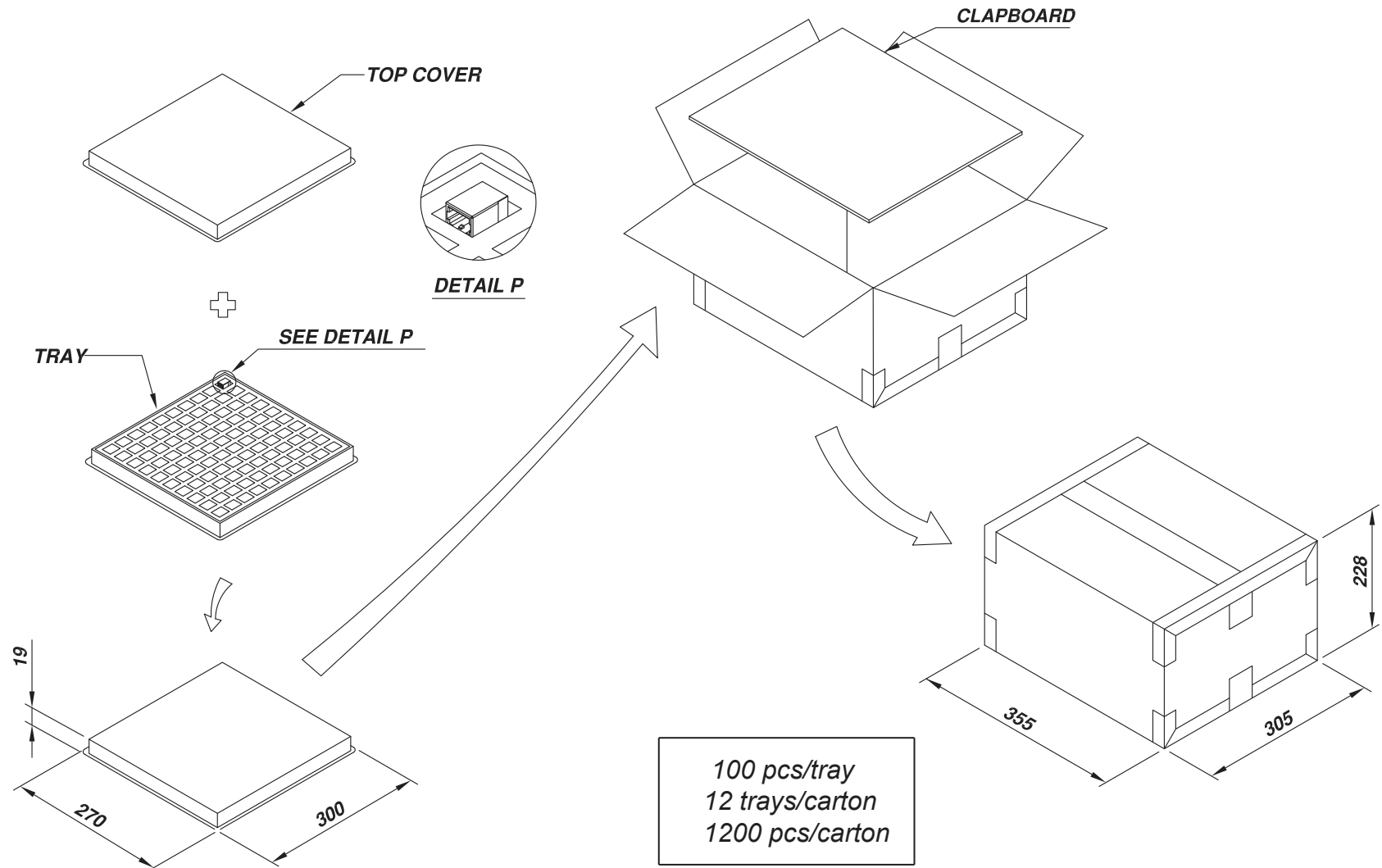

A

B

C

D

RoHS Compliant			
G			
F			
E			
D			
C			
B			
A	28-AUG-14	PDF	AS
REV	DATE	FILE	BY

PROJECTION:
APPROVAL: RJ

GENERAL TOLERANCE
.X = +/- 0.2
.XX = +/- 0.15
UNIT: MM
SCALE:
SHEET: 2/3
DRAW: AS



DESCRIPTION: HORIZONTAL SHIELDED LOW PROFILE SMT 10P8C TAB DOWN
WERI PART NO: 634 008 150 021

SIZE
A4

1

2

3

4

5

Cautions and Warnings:

This electronic component is designed and developed with the intention for use in general electronics equipments.



Before incorporating the components into any equipments in the field such as aerospace, aviation, nuclear control, submarine, transportation, (automotive control, train control, ship control), transportation signal, disaster prevention, medical, public information network etc. where higher safety and reliability are especially required or if there is possibility of direct damage or injury to human body, Würth Elektronik must be asked for a written approval.

In addition, even electronic component in general electronic equipments, when used in electrical circuits that require high safety, reliability functions or performance, the sufficient reliability evaluation-check for the safety must be performed before by the user before usage.

A

B

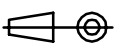
C

RoHS Compliant				PROJECTION: 	GENERAL TOLERANCE .X = +/- 0.2 .XX = +/- 0.15	 WÜRTH ELEKTRONIK	DESCRIPTION: DISCLAIMER	SIZE A4
G								
F								
E								
D								
C				APPROVAL: JC	UNIT: MM	WERI PART NO: DISCLAIMER	SIZE A4	
B					SCALE:			
A	10-SEP-14	PDF	QL		SHEET: 3/3			
REV	DATE	FILE	BY		DRAW: QL			

D