

THIS DRAWING IS UNPUBLISHED. RELEASED FOR PUBLICATION 20  
 © COPYRIGHT 20 BY - ALL RIGHTS RESERVED.

REVISIONS				
P	LTR	DESCRIPTION	DATE	APVD
A		INITIAL RELEASE	22OCT2016	DW CW
A1		ECR-17-008404	10JUN2017	CH CW

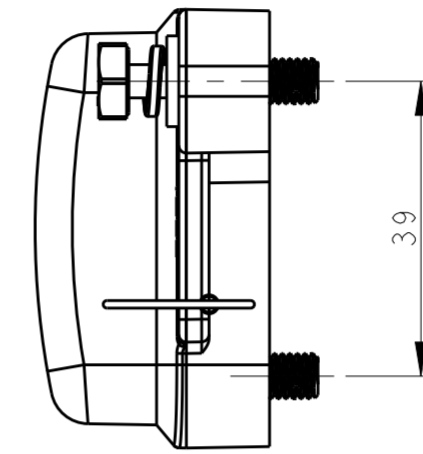

LOOP SIZE DEFAULT VALUE DIA.  $\phi$ 18,  
 UNLESS HAVE SPECIAL REQUIREMENT.  
 套圈大小默认值直径是 $\phi$ 18, 除非有特别要求.

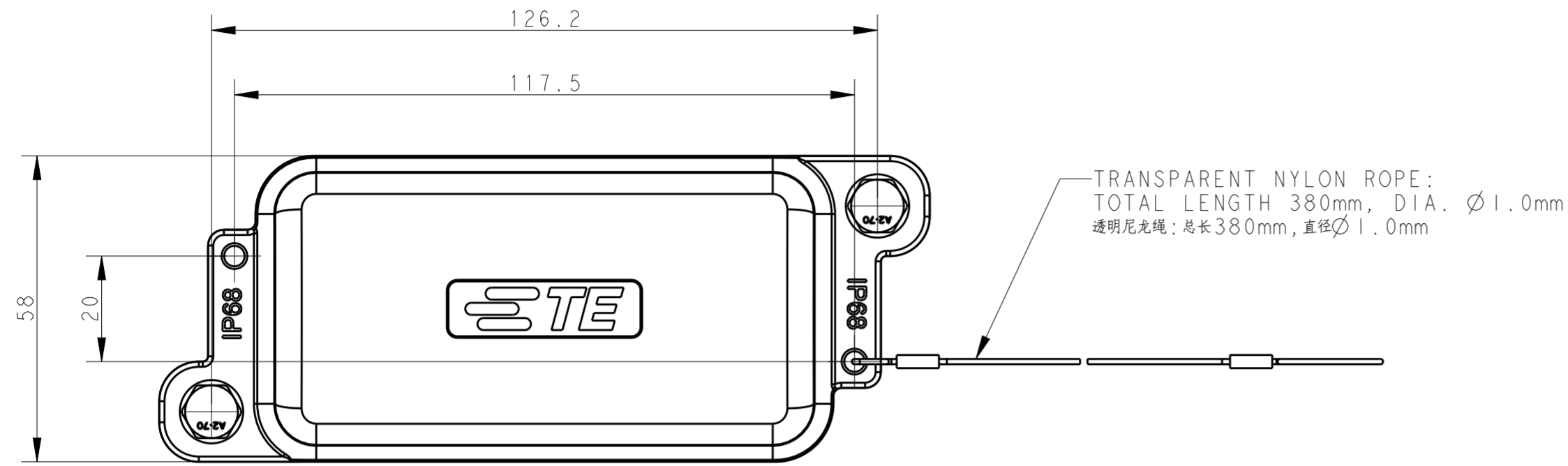
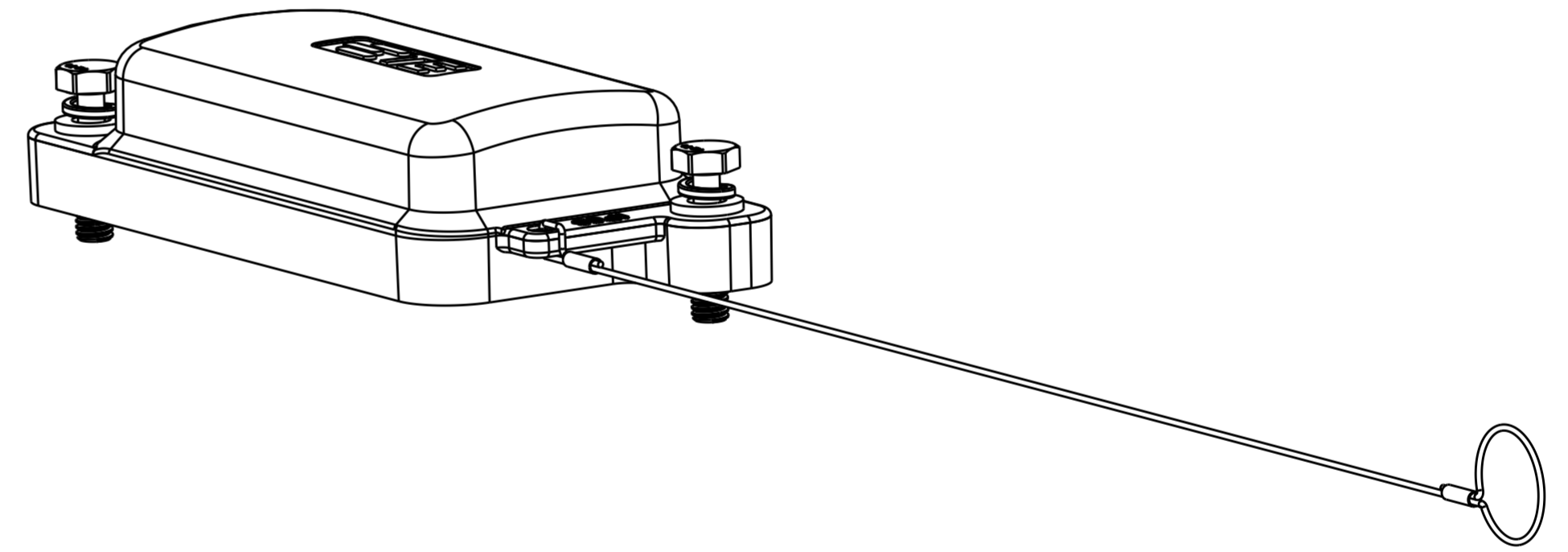
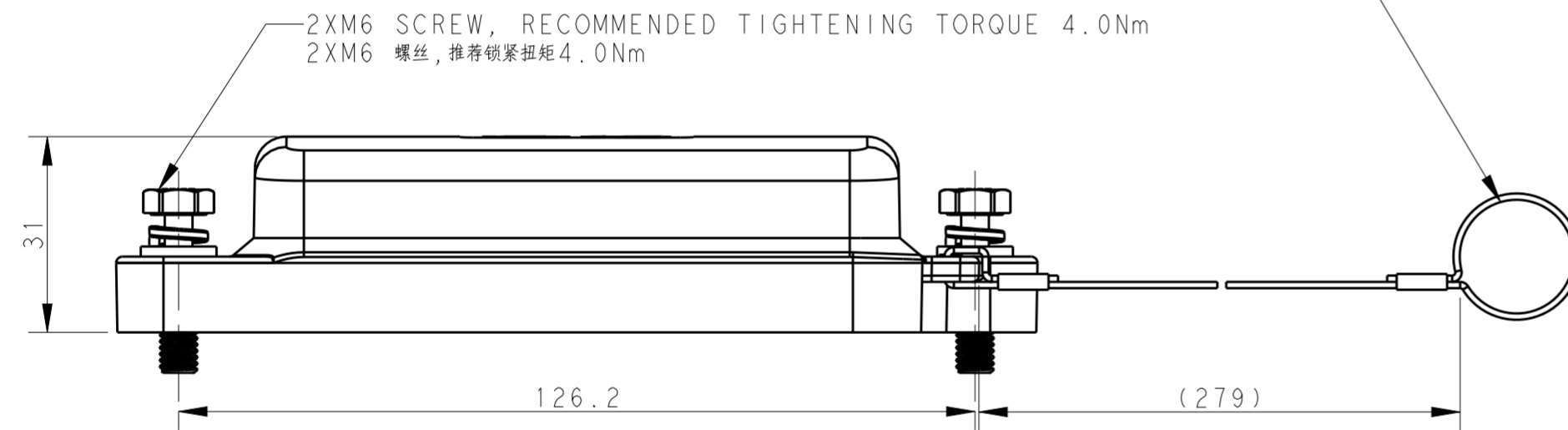

NOTES:  
 1. TECHNICAL CHARACTERISTICS:  
 COVER MATERIAL: DIE CAST ALUMINIUM ALLOY  
 SURFACE TREATMENT: SEE TABLE

注释  
 1. 技术参数:  
 壳体材料: 铝合金  
 表面处理: 见表格

T1990100000-009	H10BPR-KDBM-EMC-C	H10BPR HOUSING METAL PROTECTION COVER, DIAGONAL LOCKING, NYLON ROPE, PASSIVATION+POWDER COATED, BLACK / H10BPR对角锁定金属保护盖, 尼龙绳, 钝化+黑色粉末喷涂
PART NUMBER	PART DESCRIPTION	
料号	描述	

THIS DRAWING IS A CONTROLLED DOCUMENT.		DWN 22OCT2016 DAVID.WANG	 TE Connectivity	
DIMENSIONS:		CHK 22OCT2016 CHRIS.WANG		
mm		APVD 22OCT2016 XIANG.XU	NAME H10BPR-KDBM-EMC-C	
TOLERANCES UNLESS OTHERWISE SPECIFIED:		PRODUCT SPEC	SIZE A2	
0 PLC $\pm$		APPLICATION SPEC	CAGE CODE -	
1 PLC $\pm$		WEIGHT -	DRAWING NO. C-T1990100000009	
2 PLC $\pm$		CUSTOMER DRAWING	RESTRICTED TO -	
3 PLC $\pm$		SCALE 1:1	SHEET 1 OF 1	
4 PLC $\pm$		REV A1		
ANGLES $\pm$				
FINISH -				