

- 1
- 2
- 3
- 4
- 5
- 6
- 7
- 8
- 9
- 10
- 11
- 12
- 13
- 14
- 15
- 16
- 17
- 18

MATERIAL

Glass-fibre reinforced polyamide based (PA) technopolymer, black colour, matte finish.

STANDARD EXECUTIONS

- **L.652-B:** brass boss, plain or threaded blind hole.
- Black, orange, yellow, red and green colours, matte finish.
- **L.652-p:** zinc-plated steel threaded stud, chamfered flat end
UNI 947 : ISO 4753 (see Technical data on page A-10).

TECHNICAL DATA

Tensile stress: F values reported in the table are the result of breaking tests carried out with the appropriate dynamometric equipment under the test conditions shown in the figure with ambient temperature.

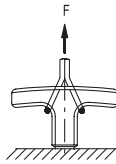

ELESA Original design

L.652-B

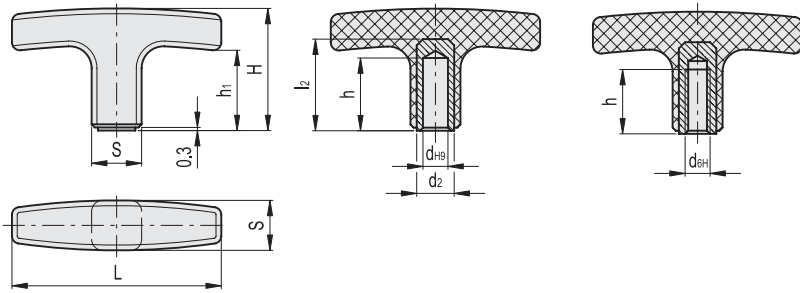

Conversion Table 1 mm = 0.039 inch	
mm	inch
41	1.61
56.5	2.20
68.5	2.67
82	3.20
94	3.70

* Complete with colour index, example: 32426-C2 L.652/40 B-M6-C2

- C9**
RAL9005
- C2**
RAL2004
- C4**
RAL1021
- C6**
RAL3000
- C17**
RAL6017

METRIC

L.652-B

Code C9	Code C2	Code C4	Code C6	Code C17	Description	L	dH9	dH6	S	H	d2	h	h1	l2	F [N]	⚖️
32420	-	-	32420-C6	-	L.652/40 B-M5*	41	-	M5	13	28	-	16	18.5	-	2400	17
32421	-	-	-	-	L.652/40 B-6*	41	6	-	13	28	9	18	18.5	23	2500	16
32426	32426-C2	32426-C4	32426-C6	32426-C17	L.652/40 B-M6*	41	-	M6	13	28	-	16	18.5	-	2500	16
32430	-	-	-	-	L.652/55 B-M5*	56.5	-	M5	15	33	-	15	21.5	-	2400	28
32431	-	-	-	-	L.652/55 B-6*	56.5	6	-	15	33	10	18	21.5	27	3300	27
32436	32436-C2	32436-C4	32436-C6	32436-C17	L.652/55 B-M6*	56.5	-	M6	15	33	-	18	21.5	-	3300	27
32432	-	-	32432-C6	-	L.652/55 B-M8*	56.5	-	M8	15	33	-	20	21.5	-	3300	28
32441	-	-	-	-	L.652/67 B-6*	68.5	6	-	16.5	37	11	20	24.5	30	4500	38
32443	-	-	-	-	L.652/67 B-8*	68.5	8	-	16.5	37	11	20	24.5	30	4500	36
32446	32446-C2	32446-C4	32446-C6	32446-C17	L.652/67 B-M8*	68.5	-	M8	16.5	37	-	20	24.5	-	4500	36
32452	-	-	32452-C6	-	L.652/67 B-M10*	68.5	-	M10	16.5	37	-	20	24.5	-	5000	34
32451	-	-	-	-	L.652/80 B-6*	82	6	-	20	41.5	13	25	25	33	7000	58
32453	-	-	-	-	L.652/80 B-8*	82	8	-	20	41.5	13	25	25	33	7000	52
32456	-	-	32456-C6	-	L.652/80 B-M8*	82	-	M8	20	41.5	-	25	25	-	7000	50
32458	32458-C2	32458-C4	32458-C6	32458-C17	L.652/80 B-M10*	82	-	M10	20	41.5	-	25	25	-	7000	56
32460	-	-	32460-C6	-	L.652/80 B-M12*	82	-	M12	20	41.5	-	18	25	-	7000	62
32471	-	-	-	-	L.652/95 B-6*	94	6	-	21	46	13	25	28.5	33	8000	74
32476	-	-	-	-	L.652/95 B-M8*	94	-	M8	21	46	-	25	28.5	-	8000	72
32478	-	-	-	-	L.652/95 B-M10*	94	-	M10	21	46	-	25	28.5	-	8000	70
32480	-	-	-	-	L.652/95 B-M12*	94	-	M12	21	46	-	25	28.5	-	8000	66

Fixed & Revolving handles



Conversion Table	
1 mm = 0.039 inch	
L	
mm	inch
41	1.61
56.5	2.20
68.5	2.67
82	3.20
94	3.70

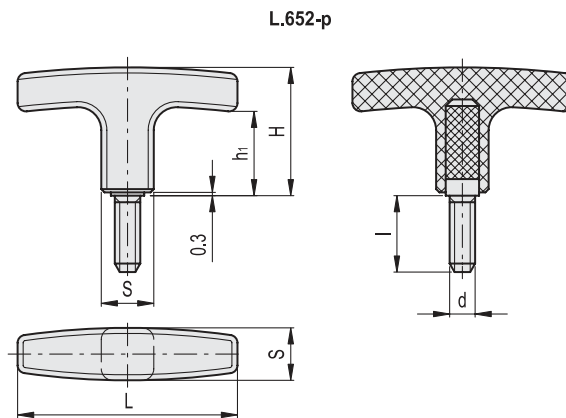

L.652-p

METRIC

Code	Description	L	d _{6g}	S	H	h ₁	l	F [N]	⚖
32425	L.652/40 p-M5x16-C9	41	M5	13	28	18.5	16	2500	15
32423	L.652/40 p-M5x20-C9	41	M5	13	28	18.5	20	2500	16
32429	L.652/40 p-M6x20-C9	41	M6	13	28	18.5	20	2500	17
32424	L.652/40 p-M6x25-C9	41	M6	13	28	18.5	25	2500	18
32433	L.652/55 p-M6x20-C9	56.5	M6	15	33	21.5	20	2500	26
32434	L.652/55 p-M6x25-C9	56.5	M6	15	33	21.5	25	3000	27
32439	L.652/55 p-M8x20-C9	56.5	M8	15	33	21.5	20	3300	28
32437	L.652/55 p-M8x25-C9	56.5	M8	15	33	21.5	25	3300	29
32440	L.652/67 p-M8x20-C9	68.5	M8	16.5	37	24.5	20	3300	36
32449	L.652/67 p-M8x25-C9	68.5	M8	16.5	37	24.5	25	3300	38
32442	L.652/67 p-M8x30-C9	68.5	M8	16.5	37	24.5	30	3300	40
32444	L.652/67 p-M10x20-C9	68.5	M10	16.5	37	24.5	20	5000	41
32445	L.652/67 p-M10x30-C9	68.5	M10	16.5	37	24.5	30	5000	44
32461	L.652/80 p-M10x20-C9	82	M10	20	41.5	25	20	5000	52
32462	L.652/80 p-M10x30-C9	82	M10	20	41.5	25	30	5000	58
32943	L.652/95 p-M12x30-C9	94	M12	21	46	28.5	30	6000	68

Fixed & Revolving handles