

98200 Series

LCD Maintenance/Hour Meters



DESCRIPTION

Honeywell 98200 Series maintenance/hour meters keep an LCD readout of elapsed time in hours and tenths. An internal battery keeps the display visible at all times.

Every 50 hours, the meter displays a maintenance reminder for service.

FEATURES

- Digital LCD readout
- Internal battery
- Snap-in case
- 50-hour alarm for maintenance (optional)
- Terminal designed to accept Packard connector 2973781
- IP66 sealing

POTENTIAL APPLICATIONS

- Commercial lawn care equipment
- Mowers
- Generators
- Compressors
- Small engine vehicles and equipment
- Panel assemblies
- Sport vehicles

BENEFITS

- Display is visible at all times
- Snap-in mounting requires no additional hardware
- Hour glass running indicator
- Maintenance alarm
- Large digital readout

98200 Series

SPECIFICATIONS

Characteristic	Parameter
Range	0 to 99,999.9 hours
Running indicator	Yes
Maintenance alert	50-hour intervals
Run accuracy	±0.02 % (over voltage and temperature range)
Operating voltage range	9 Vdc to 16 Vdc
Shock	55 g per SAE J1378
Vibration	20 g per SAE J1378
Humidity	95 % RH per SAE J1378
High pressure spray	1000 psi at 101,6 mm [4 in] and 4 GPM with 15° fan-shaped nozzle
Operating temperature	-40 °C to 71 °C [-40 °F to 160 °F]
Storage temperature	-50 °C to 85 °C [-58 °F to 185 °F]
Transient immunity	Overvoltage – yes Load dump – yes Inductive – yes EMI – yes Reverse polarity – yes
Panel mounting	Snap-in
Panel opening	36,83 mm x 24,13 mm [1.45 in x 0.95 in]
Case sealing technique – front	Ultrasonic weld
Case sealing technique – rear	Sealant on terminals
Start time	< 1 s
Material – case	Makroblend
Material – lens	Lexan
Case depth	1.35 in (including terminals)
Termination	0.25 in spade (mates with Packard connector 2973781)

LCD Maintenance/Hour Meters

MOUNTING DIMENSIONS (For reference only. mm [in])

98200 Series

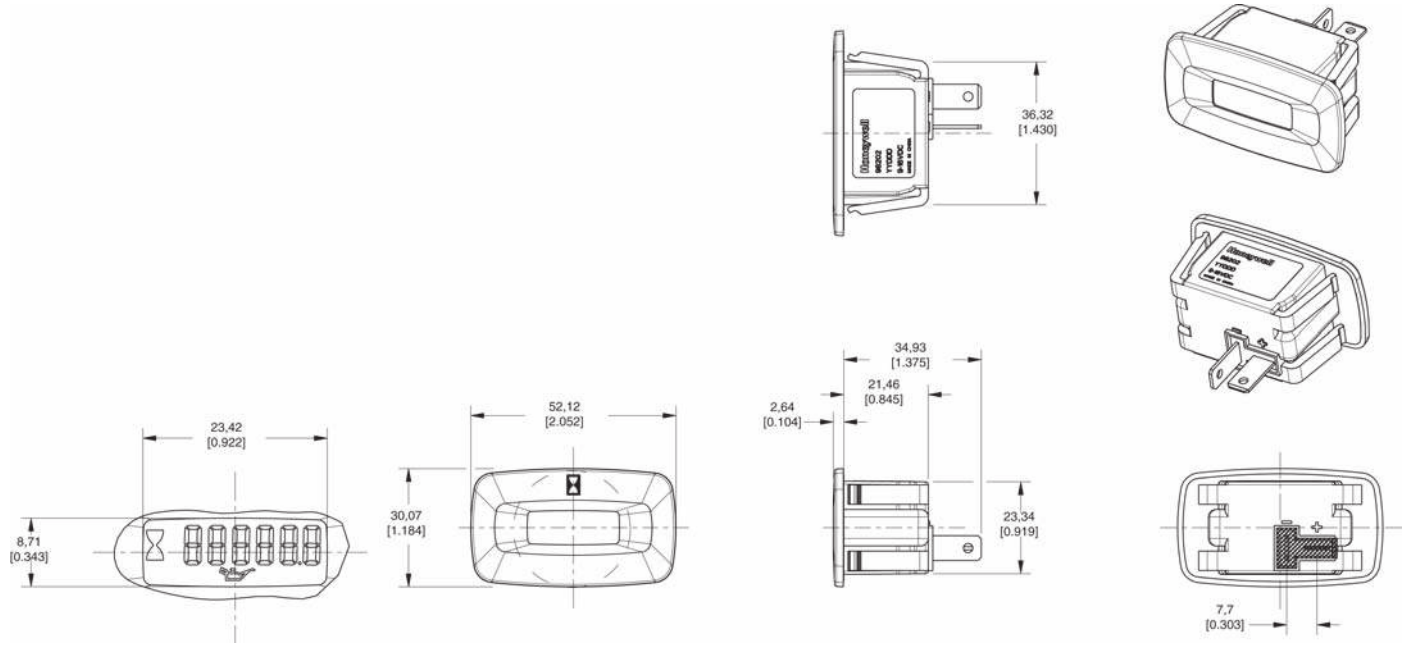

ORDER GUIDE

Catalog listing	Description
098203 99	LCD maintenance & hour meter
098204 99	LCD hour meter

WARNING

PERSONAL INJURY

DO NOT USE these products as safety or emergency stop devices or in any other application where failure of the product could result in personal injury.

Failure to comply with these instructions could result in death or serious injury.

WARNING

MISUSE OF DOCUMENTATION

- The information presented in this product sheet is for reference only. Do not use this document as a product installation guide.
- Complete installation, operation, and maintenance information is provided in the instructions supplied with each product.

Failure to comply with these instructions could result in death or serious injury.

WARRANTY/REMEDY

Honeywell warrants goods of its manufacture as being free of defective materials and faulty workmanship. Honeywell's standard product warranty applies unless agreed to otherwise by Honeywell in writing; please refer to your order acknowledgement or consult your local sales office for specific warranty details. If warranted goods are returned to Honeywell during the period of coverage, Honeywell will repair or replace, at its option, without charge those items it finds defective. **The foregoing is buyer's sole remedy and is in lieu of all other warranties, expressed or implied, including those of merchantability and fitness for a particular purpose. In no event shall Honeywell be liable for consequential, special, or indirect damages.**

While we provide application assistance personally, through our literature and the Honeywell web site, it is up to the customer to determine the suitability of the product in the application.

Specifications may change without notice. The information we supply is believed to be accurate and reliable as of this printing. However, we assume no responsibility for its use.

SALES AND SERVICE

Honeywell serves its customers through a worldwide network of sales offices, representatives and distributors. For application assistance, current specifications, pricing or name of the nearest Authorized Distributor, contact your local sales office or:

E-mail: info.sc@honeywell.com

Internet: www.honeywell.com/sensing

Phone and Fax:

Asia Pacific	+65 6355-2828
	+65 6445-3033 Fax
Europe	+44 (0) 1698 481481
	+44 (0) 1698 481676 Fax
Latin America	+1-305-805-8188
	+1-305-883-8257 Fax
USA/Canada	+1-800-537-6945
	+1-815-235-6847
	+1-815-235-6545 Fax

Sensing and Control

Honeywell

1985 Douglas Drive North

Golden Valley, Minnesota 55422

www.honeywell.com/sensing

009572-2-EN IL50 GLO Printed in USA
March 2008

Copyright © 2008 Honeywell International Inc. All rights reserved.

Honeywell