

BGB717L7ESD

Low Noise Amplifier MMIC for FM Radio Applications

Data Sheet

Revision 3.4, 2012-11-07

Edition 2012-11-07

**Published by
Infineon Technologies AG
81726 Munich, Germany**

**© 2013 Infineon Technologies AG
All Rights Reserved.**

Legal Disclaimer

The information given in this document shall in no event be regarded as a guarantee of conditions or characteristics. With respect to any examples or hints given herein, any typical values stated herein and/or any information regarding the application of the device, Infineon Technologies hereby disclaims any and all warranties and liabilities of any kind, including without limitation, warranties of non-infringement of intellectual property rights of any third party.

Information

For further information on technology, delivery terms and conditions and prices, please contact the nearest Infineon Technologies Office (www.infineon.com).

Warnings

Due to technical requirements, components may contain dangerous substances. For information on the types in question, please contact the nearest Infineon Technologies Office.

Infineon Technologies components may be used in life-support devices or systems only with the express written approval of Infineon Technologies, if a failure of such components can reasonably be expected to cause the failure of that life-support device or system or to affect the safety or effectiveness of that device or system. Life support devices or systems are intended to be implanted in the human body or to support and/or maintain and sustain and/or protect human life. If they fail, it is reasonable to assume that the health of the user or other persons may be endangered.

BGB717L7ESD, Low Noise Amplifier MMIC for FM Radio Applications

Revision History: 2012-11-07, Revision 3.4

Page	Subjects (changes since previous revision)
	This data sheet replaces the revision from 2010-06-24. The product itself has not been changed and the device characteristics remain unchanged. Only the product description and information available in the data sheet have been expanded and updated.

Trademarks of Infineon Technologies AG

AURIX™, C166™, CanPAK™, CIPOS™, CIPURSE™, EconoPACK™, CoolMOS™, CoolSET™, CORECONTROL™, CROSSAVE™, DAVE™, DI-POL™, EasyPIM™, EconoBRIDGE™, EconoDUAL™, EconoPIM™, EconoPACK™, EiceDRIVER™, eupec™, FCOS™, HITFET™, HybridPACK™, I²RF™, ISOFACE™, IsoPACK™, MIPAQ™, ModSTACK™, my-d™, NovalithIC™, OptiMOS™, ORIGA™, POWERCODE™; PRIMARION™, PrimePACK™, PrimeSTACK™, PRO-SIL™, PROFET™, RASIC™, ReverSave™, SatRIC™, SIEGET™, SINDRION™, SIPMOS™, SmartLEWIS™, SOLID FLASH™, TEMPFET™, thinQ!™, TRENCHSTOP™, TriCore™.

Other Trademarks

Advance Design System™ (ADS) of Agilent Technologies, AMBA™, ARM™, MULTI-ICE™, KEIL™, PRIMECELL™, REALVIEW™, THUMB™, μVision™ of ARM Limited, UK. AUTOSAR™ is licensed by AUTOSAR development partnership. Bluetooth™ of Bluetooth SIG Inc. CAT-iq™ of DECT Forum. COLOSSUS™, FirstGPS™ of Trimble Navigation Ltd. EMV™ of EMVCo, LLC (Visa Holdings Inc.). EPCOS™ of Epcos AG. FLEXGO™ of Microsoft Corporation. FlexRay™ is licensed by FlexRay Consortium. HYPERTERMINAL™ of Hilgraeve Incorporated. IEC™ of Commission Electrotechnique Internationale. IrDA™ of Infrared Data Association Corporation. ISO™ of INTERNATIONAL ORGANIZATION FOR STANDARDIZATION. MATLAB™ of MathWorks, Inc. MAXIM™ of Maxim Integrated Products, Inc. MICROTEC™, NUCLEUS™ of Mentor Graphics Corporation. MIPI™ of MIPI Alliance, Inc. MIPS™ of MIPS Technologies, Inc., USA. muRata™ of MURATA MANUFACTURING CO., MICROWAVE OFFICE™ (MWO) of Applied Wave Research Inc., OmniVision™ of OmniVision Technologies, Inc. Openwave™ Openwave Systems Inc. RED HAT™ Red Hat, Inc. RFMD™ RF Micro Devices, Inc. SIRIUS™ of Sirius Satellite Radio Inc. SOLARIS™ of Sun Microsystems, Inc. SPANSION™ of Spansion LLC Ltd. Symbian™ of Symbian Software Limited. TAIYO YUDEN™ of Taiyo Yuden Co. TEAKLITE™ of CEVA, Inc. TEKTRONIX™ of Tektronix Inc. TOKO™ of TOKO KABUSHIKI KAISHA TA. UNIX™ of X/Open Company Limited. VERILOG™, PALLADIUM™ of Cadence Design Systems, Inc. VLYNQ™ of Texas Instruments Incorporated. VXWORKS™, WIND RIVER™ of WIND RIVER SYSTEMS, INC. ZETEX™ of Diodes Zetex Limited.

Last Trademarks Update 2011-11-11

Table of Contents

	Table of Contents	4
	List of Figures	5
	List of Tables	6
1	Product Brief	7
2	Features	8
3	Pin Configuration	9
4	Maximum Ratings	10
5	Thermal Characteristics	11
6	Operation Conditions	11
7	Electrical Characteristics	12
7.1	DC Characteristics	12
7.2	AC Characteristics	12
8	Package Information TSLP-7-1	14

List of Figures

Figure 3-1	Pinning of BGB717L7ESD in TSLP-7-1	9
Figure 5-1	Total Power Dissipation $P_{\text{tot}} = f(T_s)$	11
Figure 7-1	FM Radio Testing Circuit	12
Figure 8-1	Package Outline	14
Figure 8-2	Package Footprint	14
Figure 8-3	Marking Example (Marking BGB717L7ESD: AX)	14
Figure 8-4	Tape Dimensions	14

List of Tables

Table 3-1	Pinning Table	9
Table 4-1	Maximum Ratings at $T_A = 25\text{ °C}$	10
Table 5-1	Thermal Resistance	11
Table 6-1	Operation Conditions	11
Table 7-1	DC Characteristics at $T_A = 25\text{ °C}$	12
Table 7-2	Bill of Material	13
Table 7-3	AC Characteristics in the FM Radio LNA Application	13

1 Product Brief

The BGB717L7ESD is an advanced low noise amplifier MMIC with integrated ESD protection and active biasing specifically designed for FM antenna systems requiring high gain, reduced power consumption and very low distortion. The external components determine the gain of the FM amplifier and can also be modified to extend the operating frequency.

The device is based on Infineon Technologies' reliable high volume silicon germanium carbon (SiGe:C) technology and comes in a low profile TSLP-7-1 leadless green package

2 Features

- High performance FM radio LNA with integrated biasing
- Worldwide FM band support (76 MHz to 108 MHz)
- Integrated ESD protection for all pins (3 kV for RF input vs. GND, 2 kV for all other pin combinations, HBM)
- Very high gain at low current consumption
- High input compression point
- High input impedance
- Excellent noise figure from latest SiGe:C technology
- Integrated active biasing circuit enables stable operating point against variations in temperature or processing
- Operation voltage: 1.8 V to 4.0 V
- Power-off function
- Very small and leadless package TSLP-7-1, 2.0 x 1.3 x 0.4 mm
- Pb-free (RoHS compliant) and halogen-free package
- Qualification report according to AEC-Q101 available



Applications

- Active FM antenna systems
- Portable FM radio
- Personal headphone radio
- ISM applications

Attention: ESD (Electrostatic discharge) sensitive device, observe handling precautions

Product name	Package	Marking
BGB717L7ESD	TSLP-7-1	AX

3 Pin Configuration

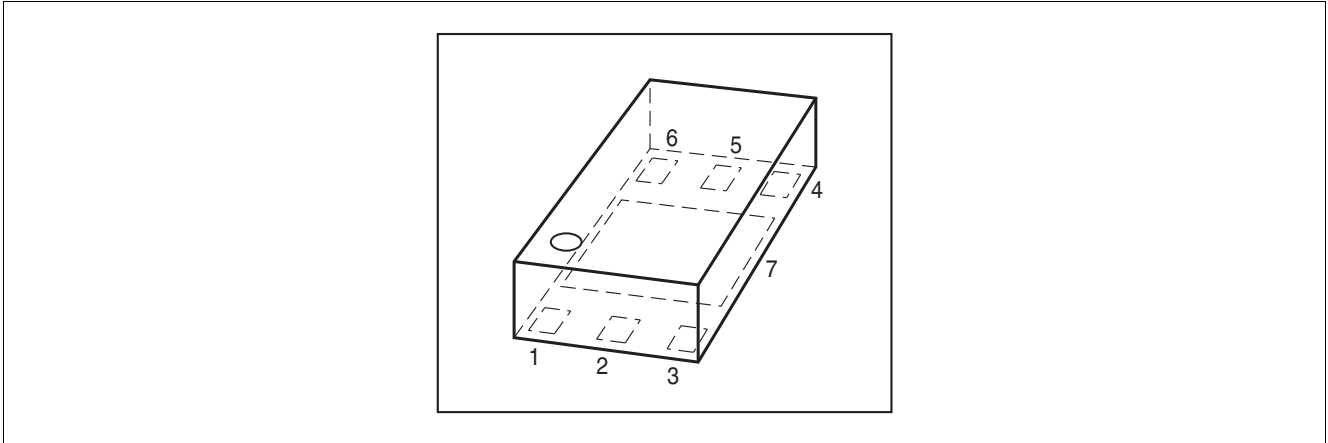

Figure 3-1 Pinning of BGB717L7ESD in TSLP-7-1

Table 3-1 Pinning Table

Pin	Function
1	GND
2	RF-In
3	Bias-Out
4	Ctrl On/Off
5	RF-Out
6	V_{CC}
7	GND

4 Maximum Ratings

Table 4-1 Maximum Ratings at $T_A = 25\text{ °C}$

Parameter	Symbol	Value			Unit	Note / Test Condition
		Min.	Typ.	Max.		
Supply voltage	V_{CC}	–	–	4.0 3.5	V	$T_A = 25\text{ °C}$ $T_A = -55\text{ °C}$
Supply current at VCC pin	I_{CC}	–	–	25	mA	–
IDC current at RF-In Pin	I_B	–	–	3	mA	–
Control On / Off voltage	V_{ctrl}	–	–	4.0	V	–
Total power dissipation ¹⁾	P_{tot}	–	–	100	mW	$T_S \leq 112\text{ °C}$
Junction temperature	T_J	–	–	150	°C	–
Storage temperature	T_{Stg}	-55	–	150	°C	–

ESD Capability

Human Body Model JESD22-A114-B	–	–	–	2000	V	–
Machine Model JESD22-A115-A	–	–	–	100	V	–
Charge Device Model JESD22-C101-C	–	–	–	1500	V	–

1) T_S is the soldering point temperature. T_S is measured at the GND pin (7) at the soldering point to the pcb

Attention: Stresses above the max. values listed here may cause permanent damage to the device. Exposure to absolute maximum rating conditions for extended periods may affect device reliability. Maximum ratings are absolute ratings; exceeding only one of these values may cause irreversible damage to the integrated circuit.

5 Thermal Characteristics

Table 5-1 Thermal Resistance

Parameter	Symbol	Values			Unit	Note / Test Condition
		Min.	Typ.	Max.		
Junction - soldering point ¹⁾	R_{thJS}	–	375	–	K/W	–

1)For the definition of R_{thJS} please refer to Application Note AN077 (Thermal Resistance Calculation)

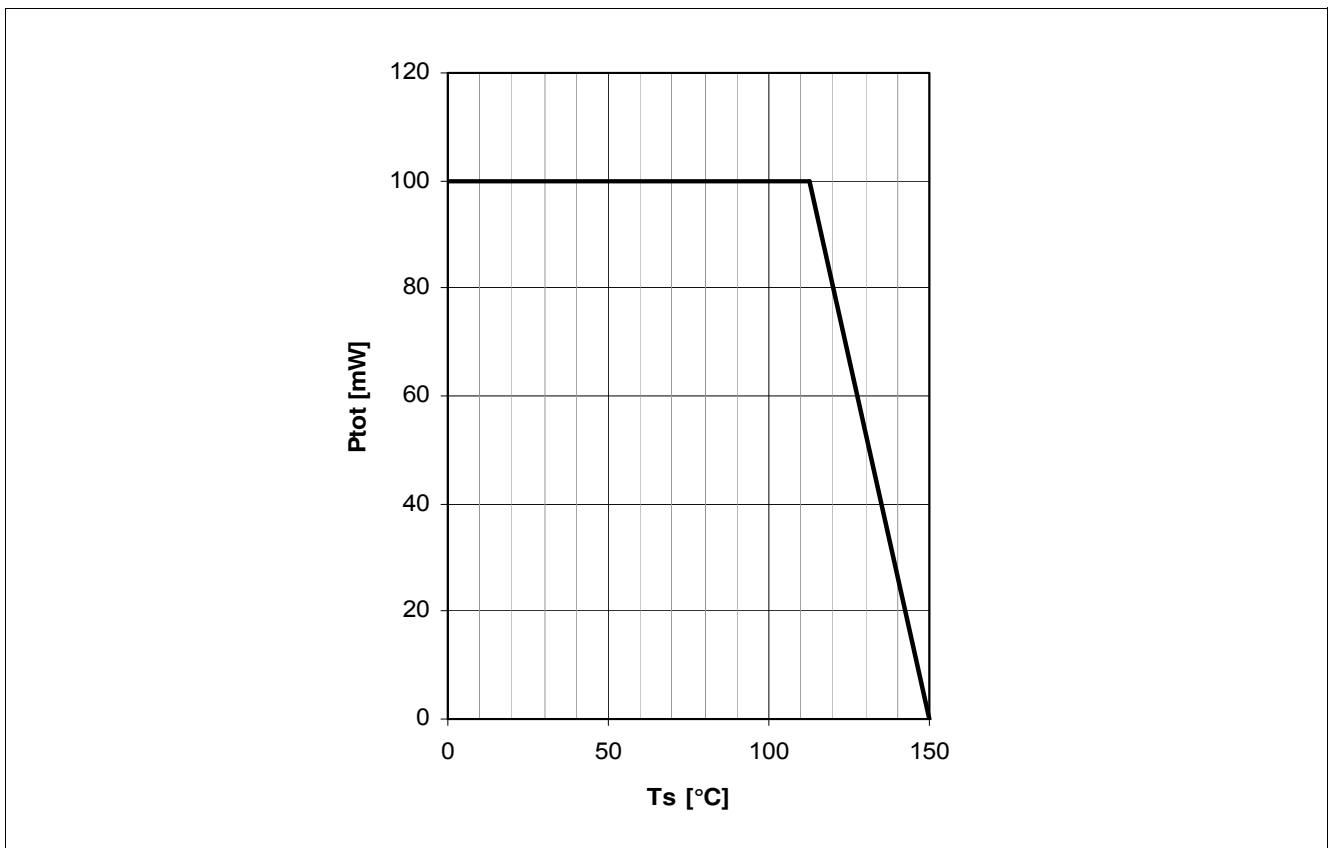
Figure 5-1 Total Power Dissipation $P_{tot} = f(T_s)$

6 Operation Conditions

Table 6-1 Operation Conditions

Parameter	Symbol	Values			Unit	Note / Test Condition
		Min.	Typ.	Max.		
Supply voltage	V_{CC}	1.8	3.0	4.0	V	–
Voltage Ctrl On/Off pin in On mode	$V_{ctrl-on}$	1.2	3.0	V_{CC}	V	–
Voltage Ctrl On/Off pin in Off mode	$V_{ctrl-off}$	-0.3	0	0.3	V	–

7 Electrical Characteristics

7.1 DC Characteristics

Table 7-1 DC Characteristics at $T_A = 25\text{ }^\circ\text{C}$

Parameter	Symbol	Values			Unit	Note / Test Condition
		Min.	Typ.	Max.		
Supply current	I_{CC}	2.4	3.0	3.6	mA	$V_{CC} = 3\text{ V}$ $V_{ctrl} = 3\text{ V}$ Small signal operation
Supply current in Off mode	I_{CC-off}	–	1	6	μA	$V_{CC} = 4.0\text{ V}$ $V_{ctrl} = 0\text{ V}$
Current into Ctrl On/Off pin in On mode	$I_{ctrl-on}$	–	14	20	μA	$V_{CC} = 3\text{ V}$ $V_{ctrl} = 3\text{ V}$
Current into Ctrl On/Off pin in Off mode	$I_{ctrl-off}$	–	–	0.1	μA	$V_{CC} = 4.0\text{ V}$ $V_{ctrl} = 0\text{ V}$

7.2 AC Characteristics

This section presents the AC characteristics of the BGB717L7ESD as measured in a high-ohmic FM radio application circuit using a PCB and a population as described in the application note AN176. Please consult our website to download the application note: www.infineon.com/rf.appnotes.

The application schematic is shown in [Figure 7-1](#) and the function of each component is explained in [Table 7-2](#).

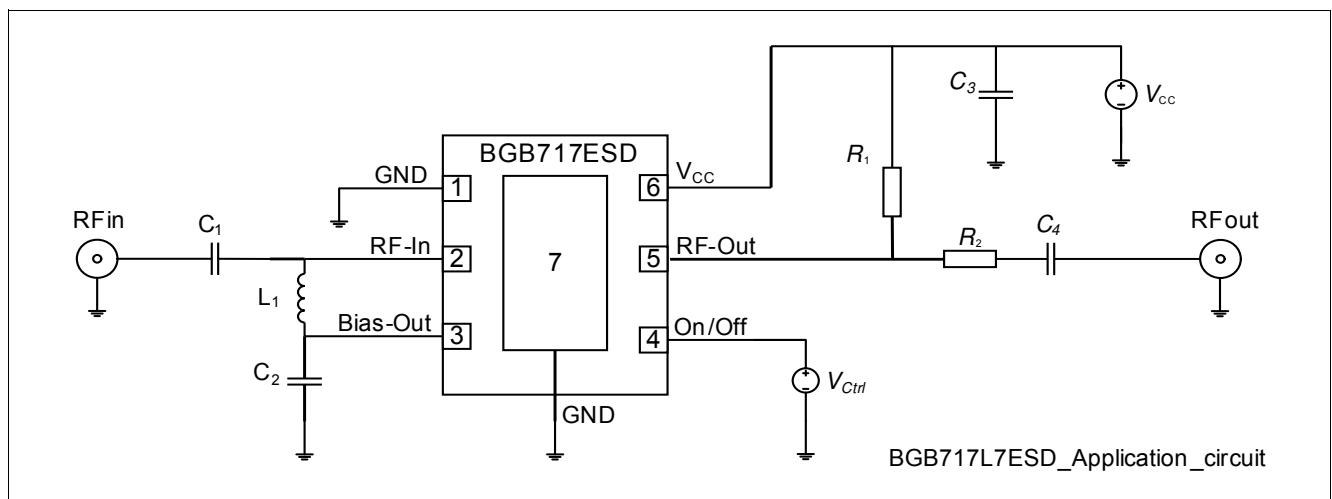

Figure 7-1 FM Radio Testing Circuit

Table 7-2 Bill of Material

Component	Value	Manufacturer / Type	Function
C ₁	330 pF	Various / 0402	DC blocking
C ₂	47 nF	Various / 0402	DC stabilization
C ₃	47 nF	Various / 0402	DC stabilization
C ₄	330 pF	Various / 0402	DC blocking
R ₁	56 Ω	Various / 0402	For biasing, output matching and stabilization
R ₂	10 Ω	Various / 0402	For output matching and stabilization
L ₁	470 nH	Taiyo Yuden LK1608R47K-T / 0603	RF choke

The following table gives an overview on the performance of the FM radio LNA application circuit. All data were measured in a 50 Ω system.

Table 7-3 AC Characteristics in the FM Radio LNA Application¹⁾

Parameter	Symbol	Values			Unit	Note / Test Condition
		Min.	Typ.	Max.		
Insertion power gain	$ S_{21} ^2$	10	12	14	dB	–
Input return loss ²⁾	RL_{IN}	0	0.5 ³⁾	3	dB	–
Output return loss ²⁾	RL_{OUT}	13	16 ⁴⁾	19	dB	–
Noise figure ⁵⁾	NF_{50}	–	1.0	1.5	dB	$Z_s = 50 \Omega$
Input 1dB gain compression point ²⁾	IP_{-1dB}	-8.0	-5.5	–	dBm	–
Input 3 rd Order Intercept Point ²⁾	IIP_3	-15.5	-12.5	–	dBm	$P_{RFIN} = -40 \text{ dBm}$

1) As described in AN176, $T_A = 25 \text{ °C}$, $V_{CC} = 3 \text{ V}$, $V_{ctrl} = 3 \text{ V}$, $I_{CC} = 3 \text{ mA}$, $f = 100 \text{ MHz}$

2) Verified by random sampling

3) High LNA input impedance leads to power matching with high ohmic antennas

4) Output matching is accomplished by the external resistors R1 and R2

5) An aggressive low pass filter prevents radio broadcast signals from distorting the NF measurement

8 Package Information TSLP-7-1

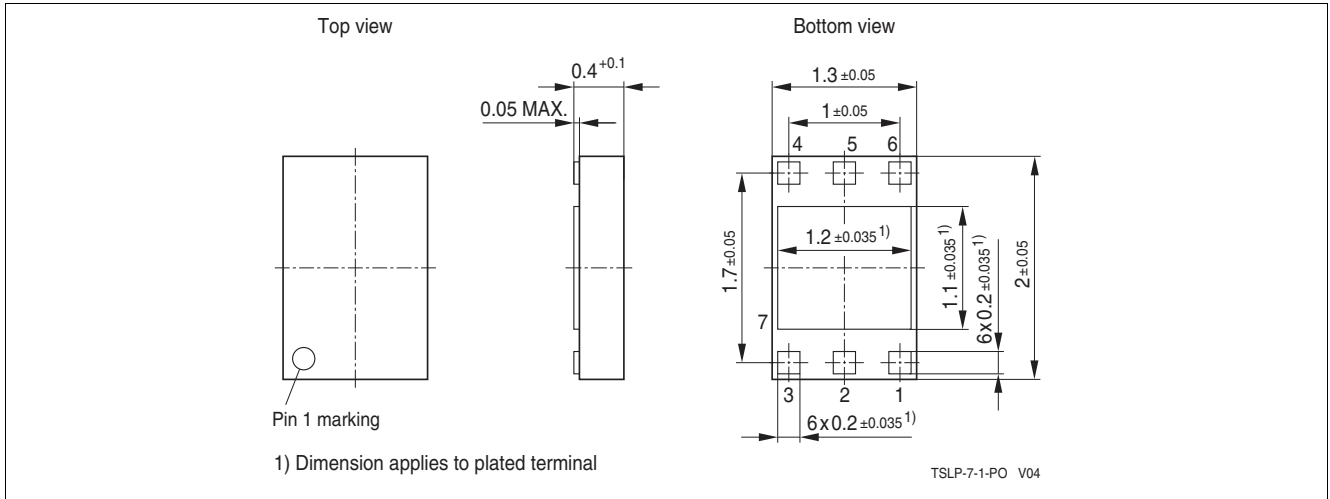

Figure 8-1 Package Outline

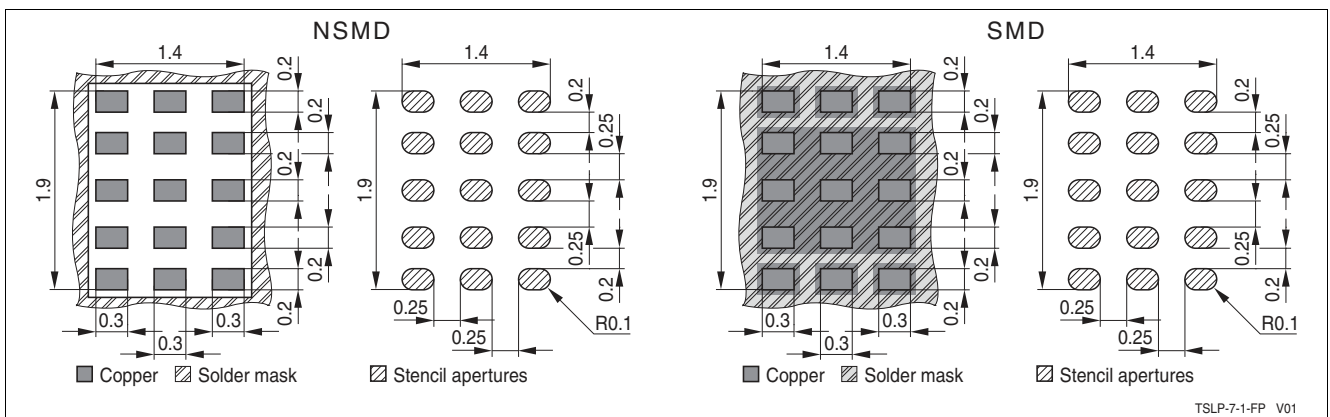

Figure 8-2 Package Footprint

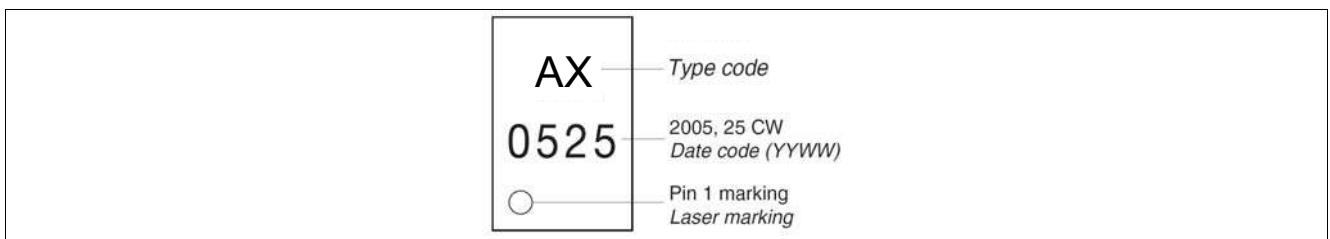

Figure 8-3 Marking Example (Marking BGB717L7ESD: AX)

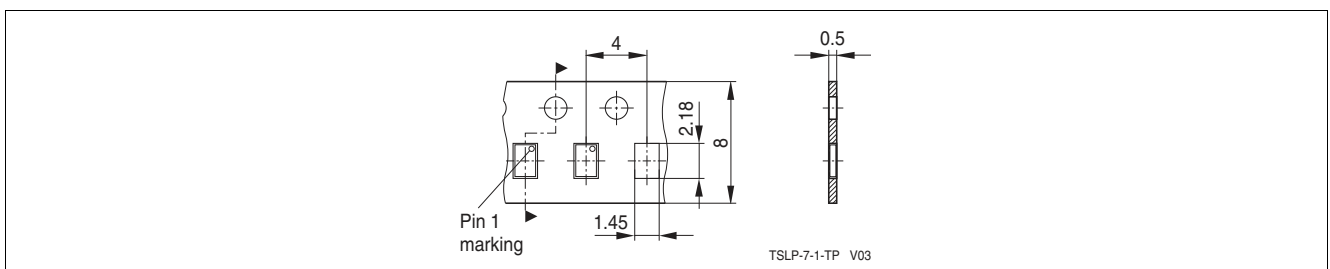

Figure 8-4 Tape Dimensions

www.infineon.com

Published by Infineon Technologies AG