

Description

The MAX4596 is a single-pole single-throw (SPST) analog switch that is designed to operate from 2 V to 5 V. This device can handle both digital and analog signals, and signals up to V_+ (peak) can be transmitted in either direction.

Applications

- Sample-and-Hold Circuits
- Battery-Powered Equipment
- Audio and Video Signal Routing
- Communication Circuits

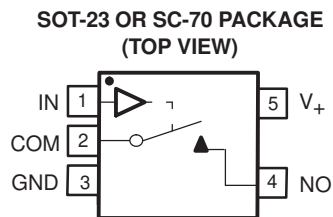

FUNCTION TABLE

IN	NO TO COM, COM TO NO
L	OFF
H	ON

Features

- Low ON-State Resistance (10 Ω)
- ON-State Resistance Flatness (1.5 Ω)
- Control Inputs Are 5.5-V Tolerant
- Low Charge Injection (5 pC Max)
- 300-MHz –3-dB Bandwidth at 25°C
- Low Total Harmonic Distortion (THD) (0.05%)
- 2-V to 5.5-V Single-Supply Operation
- Specified at 5-V and 3.3-V Nodes
- –83-dB OFF Isolation at 1 MHz
- Latch-Up Performance Exceeds 100 mA Per JESD 78, Class II
- 0.5-nA Max OFF Leakage
- ESD Performance Tested Per JESD 22
 - 2000-V Human-Body Model (A114-B, Class II)
 - 1000-V Charged-Device Model (C101)
- TTL/CMOS-Logic Compatible

Summary of Characteristics

$V_+ = 5\text{ V}$, $T_A = 25^\circ\text{C}$

Configuration	Single Pole Single Throw (SPST)
Number of channels	1
ON-state resistance (r_{ON})	10 Ω
ON-state resistance flatness ($r_{ON(flat)}$)	1.5 Ω
Turn-on/turn-off time (t_{ON}/t_{OFF})	35 ns/40 ns
Charge injection (Q_C)	5 pC
Bandwidth (BW)	300 MHz
OFF isolation (O_{ISO})	–83 dB at 1 MHz
Total harmonic distortion (THD)	0.05%
Leakage current ($I_{COM(OFF)}/I_{NO(OFF)}$)	±0.05 nA
Power-supply current (I_+)	1 μA
Package option	5-pin SOT-23 or SC-70

ORDERING INFORMATION

T_A	PACKAGE ⁽¹⁾		ORDERABLE PART NUMBER	TOP-SIDE MARKING ⁽²⁾
–40°C to 85°C	SOT (SOT-23) – DBV	Tape and reel	MAX4596DBVR	6SB_
	SOT (SC-70) – DCK	Tape and reel	MAX4596DCKR	SB_

(1) Package drawings, standard packing quantities, thermal data, symbolization, and PCB design guidelines are available at www.ti.com/sc/package.

(2) DBV/DCK: The actual top-side marking has one additional character that designates the assembly/test site.



Please be aware that an important notice concerning availability, standard warranty, and use in critical applications of Texas Instruments semiconductor products and disclaimers thereto appears at the end of this data sheet.

MAX4596 SINGLE-CHANNEL 10-Ω SPST ANALOG SWITCH

SLLS641 – JANUARY 2005

Pin Configurations

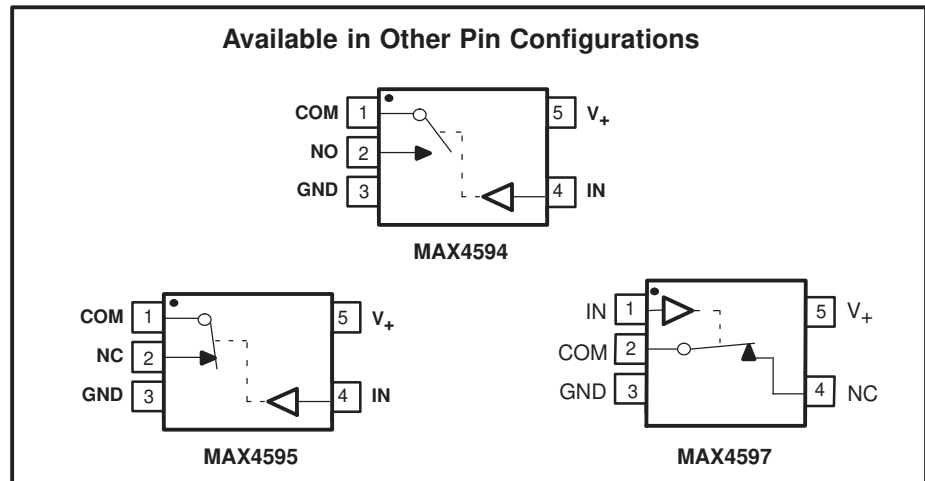
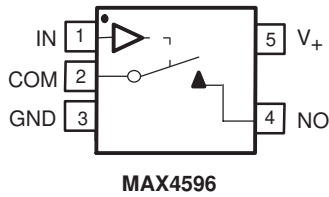

Absolute Minimum and Maximum Ratings⁽¹⁾⁽²⁾

over operating free-air temperature range (unless otherwise noted)

		MIN	MAX	UNIT
V_+	Supply voltage range ⁽³⁾	-0.3	6	V
V_{NO} V_{COM}	Analog voltage range ⁽³⁾⁽⁴⁾	-0.3	$V_+ + 0.3$	V
I_K	Analog port diode current	$V_{NO}, V_{COM} < 0$		mA
I_{NO} I_{COM}	On-state switch current	$V_{NO}, V_{COM} = 0$ to V_+		mA
I_{NO} I_{COM}	On-state switch current (pulsed at 1 ms, 10% duty cycle)	$V_{NO}, V_{COM} = 0$ to V_+		mA
V_I	Digital input voltage range ⁽³⁾⁽⁴⁾	-0.3	6	V
I_{IK}	Digital input clamp current	$V_I < 0$		mA
I_+	Continuous current through V_+			100 mA
I_{GND}	Continuous current through GND			-100 mA
θ_{JA}	Package thermal impedance ⁽⁵⁾	DBV package		206
		DCK package		252
T_{Stg}	Storage temperature range	-65	150	°C

(1) Stresses above these ratings may cause permanent damage. Exposure to absolute maximum conditions for extended periods may degrade device reliability. These are stress ratings only, and functional operation of the device at these or any other conditions beyond those specified is not implied.

(2) The algebraic convention, whereby the most negative value is a minimum and the most positive value is a maximum

(3) All voltages are with respect to ground, unless otherwise specified.

(4) The input and output voltage ratings may be exceeded if the input and output clamp-current ratings are observed.

(5) The package thermal impedance is calculated in accordance with JESD 51-7.

Electrical Characteristics for 5-V Supply⁽¹⁾
 $V_+ = 4.5\text{ V to }5.5\text{ V}$, $T_A = -40^\circ\text{C to }85^\circ\text{C}$ (unless otherwise noted)

PARAMETER	SYMBOL	TEST CONDITIONS	T_A	V_+	MIN	TYP	MAX	UNIT
Analog Switch								
Analog signal range	V_{COM} , V_{NO}				0		V_+	V
ON-state resistance	r_{on}	$V_{NO} = 3.5\text{ V}$ $I_{COM} = 10\text{ mA}$,	Switch ON, See Figure 13	25°C Full	4.5 V	6.5	10 12	Ω
ON-state resistance flatness	$r_{on(Flat)}$	$V_{NO} = 1.5\text{ V, }2.5\text{ V, }3.5\text{ V}$ $I_{COM} = 10\text{ mA}$,	Switch ON, See Figure 13	25°C Full	4.5 V	0.5	1.5 2	Ω
NO OFF leakage current	$I_{NO(OFF)}$	$V_{NO} = 1\text{ V, }V_{COM} = 4.5\text{ V}$, or $V_{NO} = 4.5\text{ V, }V_{COM} = 1\text{ V}$,	Switch OFF, See Figure 14	25°C Full	5.5 V	-0.5	0.01 0.5 5	nA
COM OFF leakage current	$I_{COM(OFF)}$	$V_{COM} = 1\text{ V, }V_{NO} = 4.5\text{ V}$, or $V_{COM} = 4.5\text{ V, }V_{NO} = 1\text{ V}$,	Switch OFF, See Figure 14	25°C Full	5.5 V	-0.5	0.01 0.5 5	nA
NO ON leakage current	$I_{NO(ON)}$	$V_{NO} = 1\text{ V, }V_{COM} = 1\text{ V}$, or $V_{NO} = 4.5\text{ V, }V_{COM} = 4.5\text{ V}$, or $V_{NO} = 1\text{ V, }4.5\text{ V, }V_{COM} = \text{Open}$,	Switch ON, See Figure 15	25°C Full	5.5 V	-1	0.01 1 10	nA
COM ON leakage current	$I_{COM(ON)}$	$V_{COM} = 1\text{ V, }V_{NO} = 1\text{ V}$, or $V_{COM} = 4.5\text{ V, }V_{NO} = 4.5\text{ V}$, or $V_{COM} = 1\text{ V, }4.5\text{ V, }V_{NO} = \text{Open}$,	Switch ON, See Figure 15	25°C Full	5.5 V	-1	0.01 1 10	nA
Digital Control Input (IN)								
Input logic high	V_{IH}			Full		2.4	5.5	V
Input logic low	V_{IL}			Full		0	0.8	V
Input leakage current	I_{IH}, I_{IL}	$V_I = V_+ \text{ or } 0$		25°C Full	5.5 V	-1	0.03 1 1	μA

⁽¹⁾ The algebraic convention, whereby the most negative value is a minimum and the most positive value is a maximum

MAX4596

SINGLE-CHANNEL 10-Ω SPST ANALOG SWITCH

SLLS641 – JANUARY 2005

Electrical Characteristics for 5-V Supply⁽¹⁾ (continued)

$V_+ = 4.5\text{ V to }5.5\text{ V}$, $T_A = -40^\circ\text{C to }85^\circ\text{C}$ (unless otherwise noted)

PARAMETER	SYMBOL	TEST CONDITIONS	T_A	V_+	MIN	TYP	MAX	UNIT
Dynamic								
Turn-on time	t_{ON}	$V_{NO} = 3\text{ V}$, $R_L = 300\ \Omega$,	$C_L = 35\ \text{pF}$, See Figure 17	25°C	5 V	20	35	ns
				Full	4.5 V to 5.5 V		45	
Turn-off time	t_{OFF}	$V_{COM} = 3\text{ V}$, $R_L = 300\ \Omega$,	$C_L = 35\ \text{pF}$, See Figure 17	25°C	5 V	25	40	ns
				Full	4.5 V to 5.5 V		50	
Charge injection	Q_C	$V_{GEN} = 0$, $R_{GEN} = 0$, $C_L = 1\ \text{nF}$,	See Figure 20	25°C	5 V	2	5	pC
NO OFF capacitance	$C_{NO(OFF)}$	$V_{NO} = V_+$ or GND, $f = 1\ \text{MHz}$,	Switch OFF, See Figure 16	25°C	5 V	8		pF
COM OFF capacitance	$C_{COM(OFF)}$	$V_{COM} = V_+$ or GND, $f = 1\ \text{MHz}$,	Switch OFF, See Figure 16	25°C	5 V	8		pF
NO ON capacitance	$C_{NO(ON)}$	$V_{NO} = V_+$ or GND, $f = 1\ \text{MHz}$,	Switch ON, See Figure 16	25°C	5 V	20		pF
COM ON capacitance	$C_{COM(ON)}$	$V_{COM} = V_+$ or GND, $f = 1\ \text{MHz}$,	Switch ON, See Figure 16	25°C	5 V	20		pF
Digital input capacitance	C_I	$V_I = V_+$ or GND,	See Figure 16	25°C	5 V	3		pF
Bandwidth	BW	$R_L = 50\ \Omega$, Signal = 0 dBm,	Switch ON, See Figure 18	25°C	5 V	300		MHz
OFF isolation	O_{ISO}	$R_L = 50\ \Omega$, $C_L = 5\ \text{pF}$, $V_{NO} = 1\ V_{RMS}$, $f = 1\ \text{MHz}$,	Switch OFF, See Figure 19	25°C	5 V	-83		dB
Total harmonic distortion	THD	$R_L = 600\ \Omega$, $C_L = 50\ \text{pF}$, $V_{SOURCE} = 5\ V_{p-p}$,	$f = 20\ \text{Hz to }20\ \text{kHz}$, See Figure 21	25°C	5 V	0.05		%
Supply								
Positive supply current	I_+	$V_I = V_+$ or GND,	Switch ON or OFF	Full	5.5 V		1	μA

(1) The algebraic convention, whereby the most negative value is a minimum and the most positive value is a maximum

Electrical Characteristics for 3-V Supply⁽¹⁾
 $V_+ = 2.7\text{ V to }3.6\text{ V}$, $T_A = -40^\circ\text{C to }85^\circ\text{C}$ (unless otherwise noted)

PARAMETER	SYMBOL	TEST CONDITIONS	T_A	V_+	MIN	TYP	MAX	UNIT
Analog Switch								
Analog signal range	V_{COM} , V_{NO}				0		V_+	V
ON-state resistance	r_{on}	$V_{NO} = 1.5\text{ V}$, $I_{COM} = 10\text{ mA}$,	Switch ON, See Figure 13	25°C Full	2.7 V	10	20 25	Ω
Digital Control Input (IN)								
Input logic high	V_{IH}			Full		2	5.5	V
Input logic low	V_{IL}			Full		0	0.8	V
Input leakage current	I_{IH} , I_{IL}	$V_I = V_+$ or 0		25°C Full	3.6 V	-1	0.03 1	μA
Dynamic								
Turn-on time	t_{ON}	$V_{NO} = 2\text{ V}$, $R_L = 300\ \Omega$,	$C_L = 35\text{ pF}$, See Figure 17	25°C Full	3 V 2.7 V to 3.6 V	25	45 55	ns
Turn-off time	t_{OFF}	$V_{NO} = 2\text{ V}$, $R_L = 300\ \Omega$,	$C_L = 35\text{ pF}$, See Figure 17	25°C Full	3 V 2.7 V to 3.6 V	30	50 60	ns
Charge injection	Q_C	$V_{GEN} = 0$, $R_{GEN} = 0$, $C_L = 1\text{ nF}$,	See Figure 20	25°C	3 V	2	4	pC
Supply								
Positive supply current	I_+	$V_I = V_+$ or GND,	Switch ON or OFF	Full	3.6 V		1	μA

⁽¹⁾ The algebraic convention, whereby the most negative value is a minimum and the most positive value is a maximum

TYPICAL PERFORMANCE

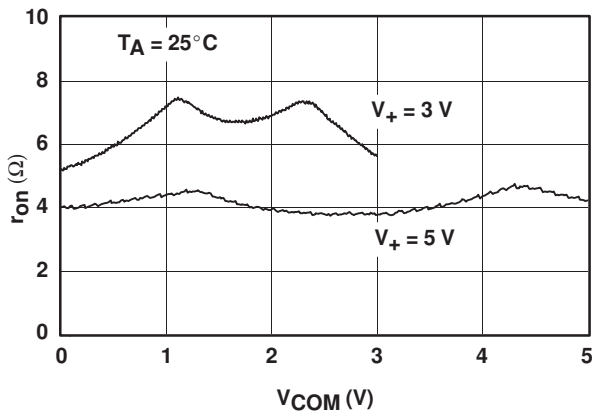

Figure 1. r_{on} vs V_{COM}

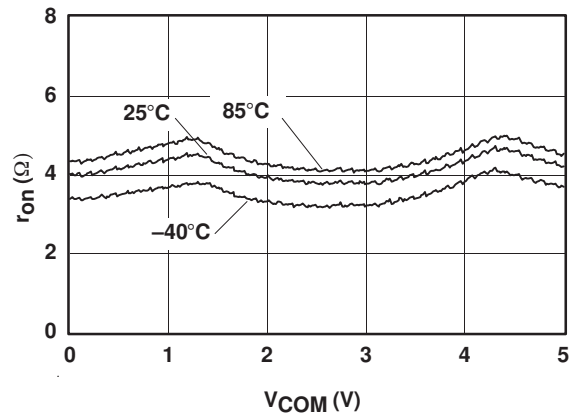

Figure 2. r_{on} vs V_{COM} ($V_+ = 5$ V)

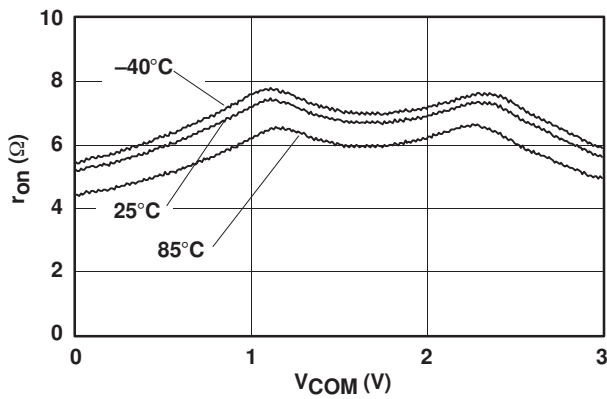

Figure 3. r_{on} vs V_{COM} ($V_+ = 3$ V)

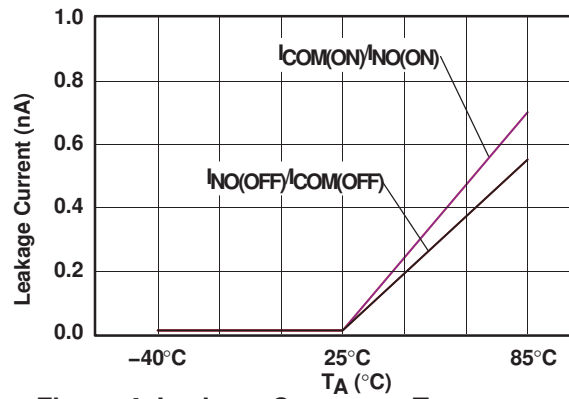

Figure 4. Leakage Current vs Temperature ($V_+ = 5$ V)

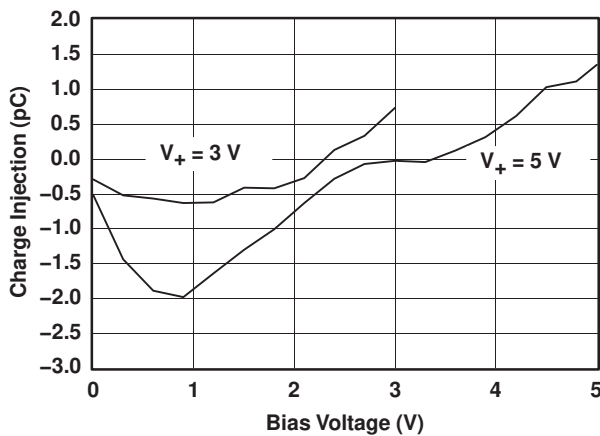

Figure 5. Charge-Injection (Q_C) vs V_{COM}

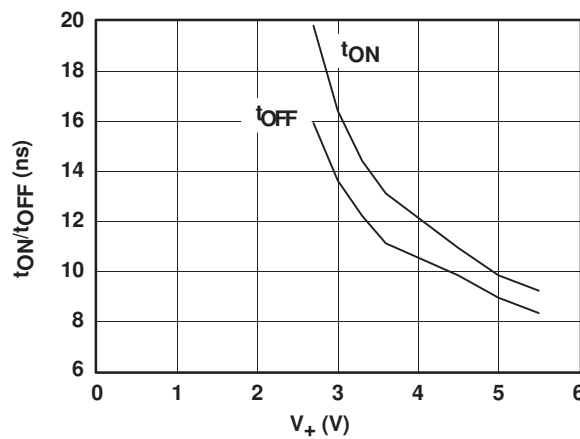

Figure 6. t_{ON} and t_{OFF} vs Supply Voltage

TYPICAL PERFORMANCE

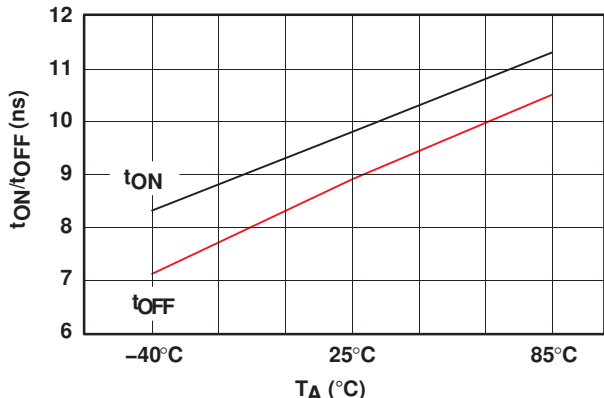

Figure 7. t_{ON} and t_{OFF} vs Temperature ($V_+ = 5\text{ V}$)

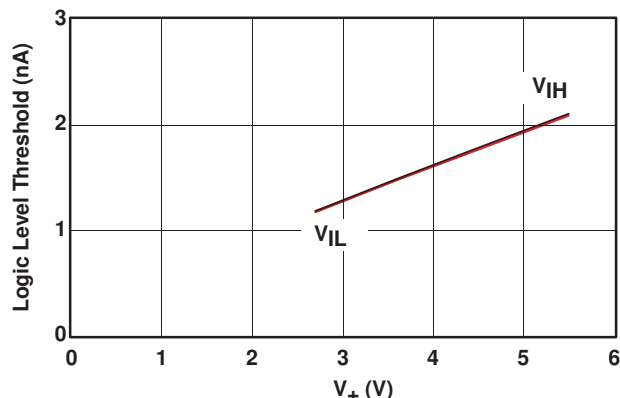

Figure 8. Logic-Level Threshold vs V_+

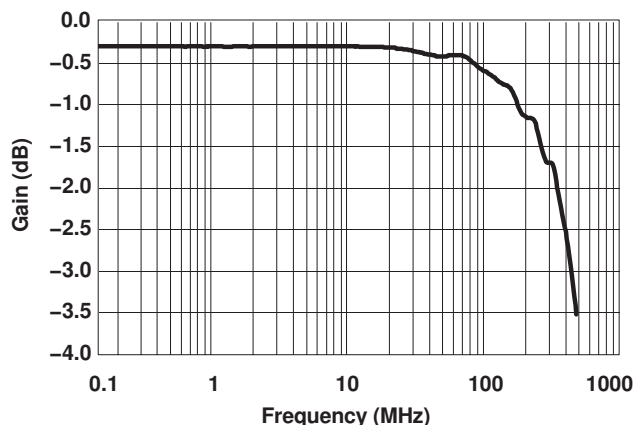

Figure 9. Bandwidth (Gain vs Frequency) ($V_+ = 5\text{ V}$)

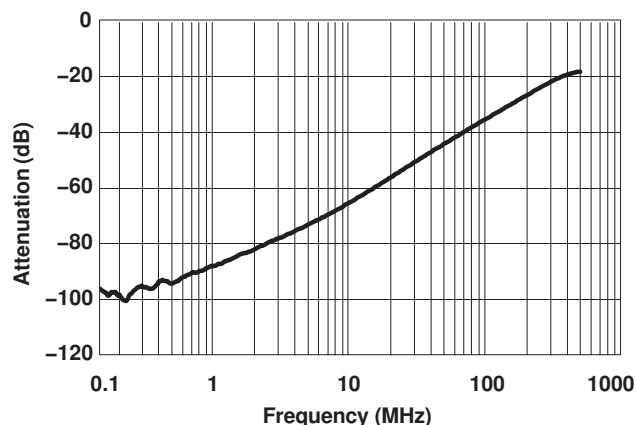

Figure 10. Off Isolation vs Frequency

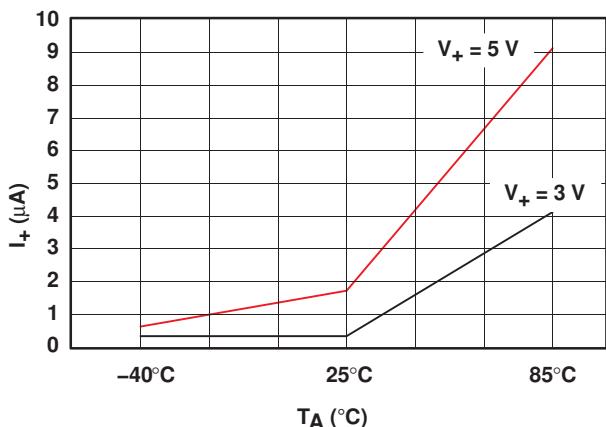

Figure 11. Power-Supply Current vs Temperature

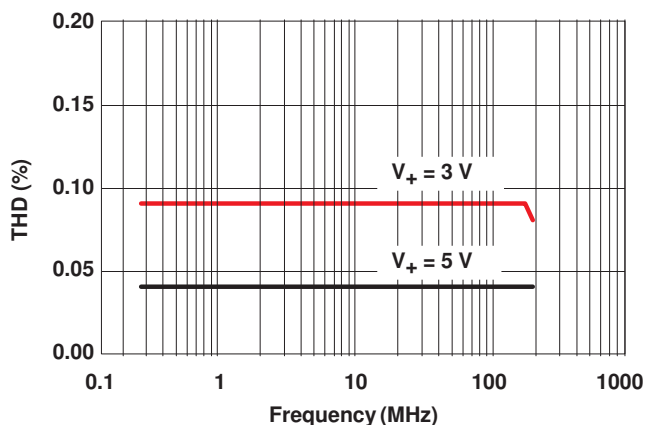

Figure 12. Total Harmonic Distortion vs Frequency

PIN DESCRIPTION

PIN NUMBER	NAME	DESCRIPTION
1	IN	Digital control pin to connect COM to NO
2	COM	Common
3	GND	Digital ground
4	NO	Normally open
5	V ₊	Power supply

PARAMETER DESCRIPTION

SYMBOL	DESCRIPTION
V _{COM}	Voltage at COM
V _{NO}	Voltage at NO
r _{on}	Resistance between COM and NO ports when the channel is ON
r _{on(flat)}	Difference between the maximum and minimum value of r _{on} in a channel over the specified range of conditions
I _{NO(OFF)}	Leakage current measured at the NO port, with the corresponding channel (NO to COM) in the OFF state
I _{NO(ON)}	Leakage current measured at the NO port, with the corresponding channel (NO to COM) in the ON state and the output (COM) open
I _{COM(OFF)}	Leakage current measured at the COM port, with the corresponding channel (COM to NO) in the OFF state
I _{COM(ON)}	Leakage current measured at the COM port, with the corresponding channel (COM to NO) in the ON state and the output (NO) open
V _{IH}	Minimum input voltage for logic high for the control input (IN)
V _{IL}	Maximum input voltage for logic low for the control input (IN)
V _I	Voltage at the control input (IN)
I _{IH} , I _{IL}	Leakage current measured at the control input (IN)
t _{ON}	Turn-on time for the switch. This parameter is measured under the specified range of conditions and by the propagation delay between the digital control (IN) signal and analog output (COM or NO) signal when the switch is turning ON.
t _{OFF}	Turn-off time for the switch. This parameter is measured under the specified range of conditions and by the propagation delay between the digital control (IN) signal and analog output (COM or NO) signal when the switch is turning OFF.
Q _C	Charge injection is a measurement of unwanted signal coupling from the control (IN) input to the analog (NO or COM) output. This is measured in coulomb (C) and measured by the total charge induced due to switching of the control input. Charge injection, Q _C = C _L × ΔV _{COM} , C _L is the load capacitance, and ΔV _{COM} is the change in analog output voltage.
C _{NO(OFF)}	Capacitance at the NO port when the corresponding channel (NO to COM) is OFF
C _{NO(ON)}	Capacitance at the NO port when the corresponding channel (NO to COM) is ON
C _{COM(OFF)}	Capacitance at the COM port when the corresponding channel (COM to NO) is OFF
C _{COM(ON)}	Capacitance at the COM port when the corresponding channel (COM to NO) is ON
C _I	Capacitance of control input (IN)
O _{ISO}	OFF isolation of the switch is a measurement of OFF-state switch impedance. This is measured in dB in a specific frequency, with the corresponding channel (NO to COM) in the OFF state.
BW	Bandwidth of the switch. This is the frequency in which the gain of an ON channel is –3 dB below the DC gain.
THD	Total harmonic distortion describes the signal distortion caused by the analog switch. This is defined as the ratio of root mean square (RMS) value of the second, third, and higher harmonic to the absolute magnitude of the fundamental harmonic.
I ₊	Static power-supply current with the control (IN) pin at V ₊ or GND

PARAMETER MEASUREMENT INFORMATION

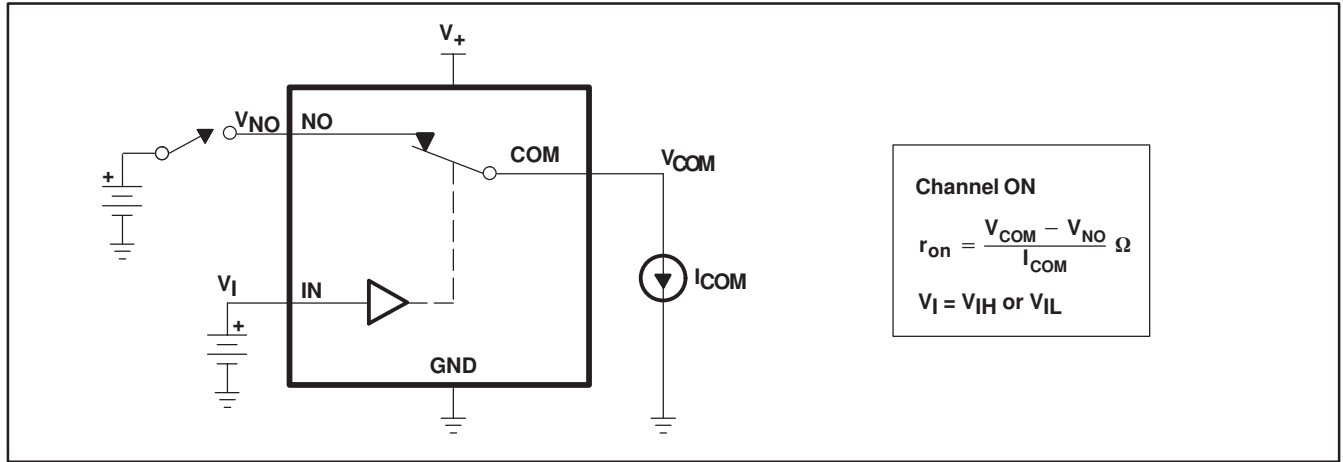

Figure 13. ON-State Resistance (r_{on})

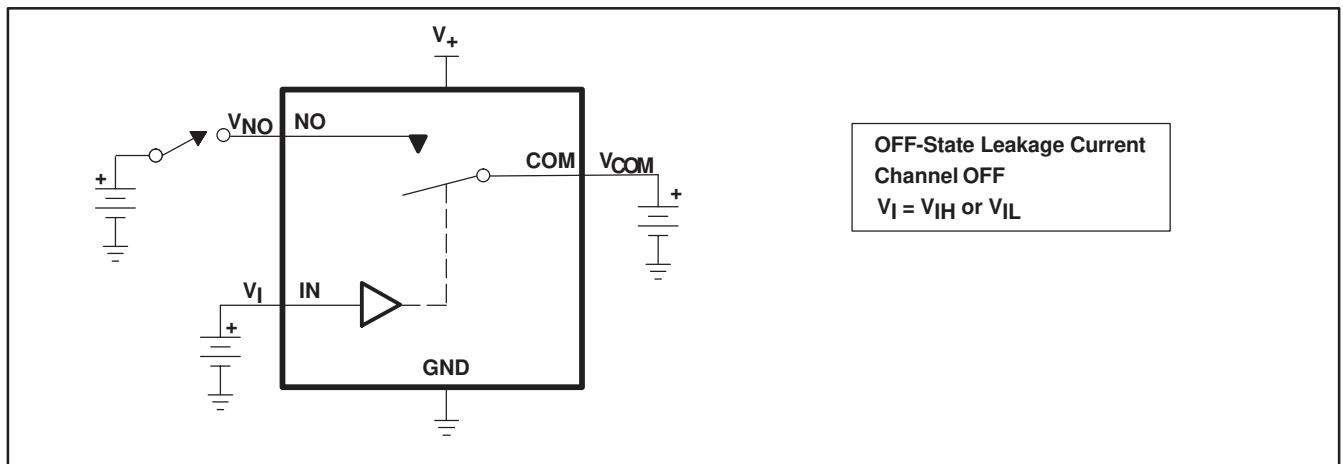

Figure 14. OFF-State Leakage Current ($I_{COM(OFF)}$, $I_{NO(OFF)}$)

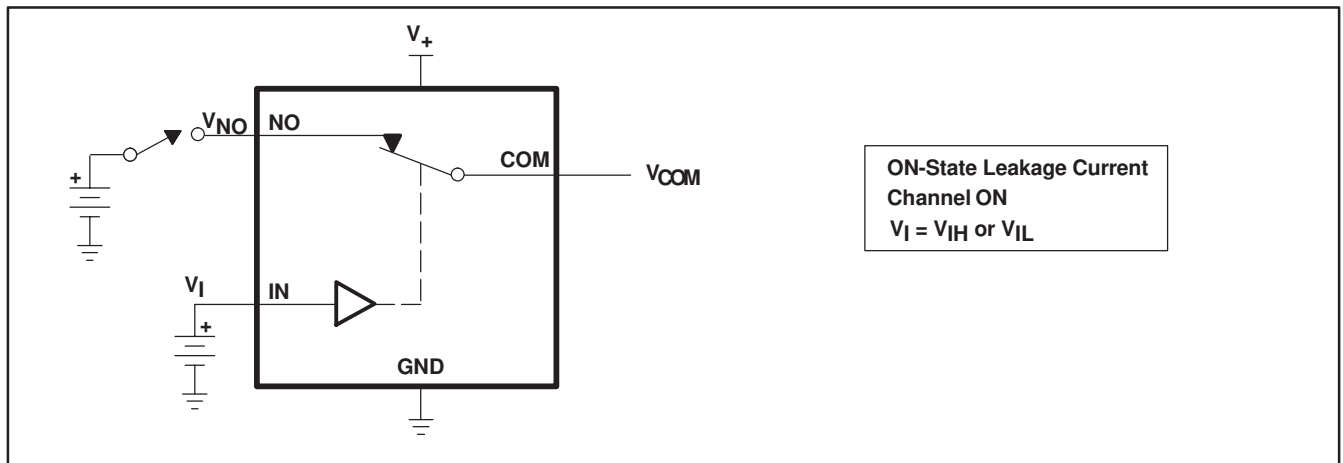

Figure 15. ON-State Leakage Current ($I_{COM(ON)}$, $I_{NO(ON)}$)

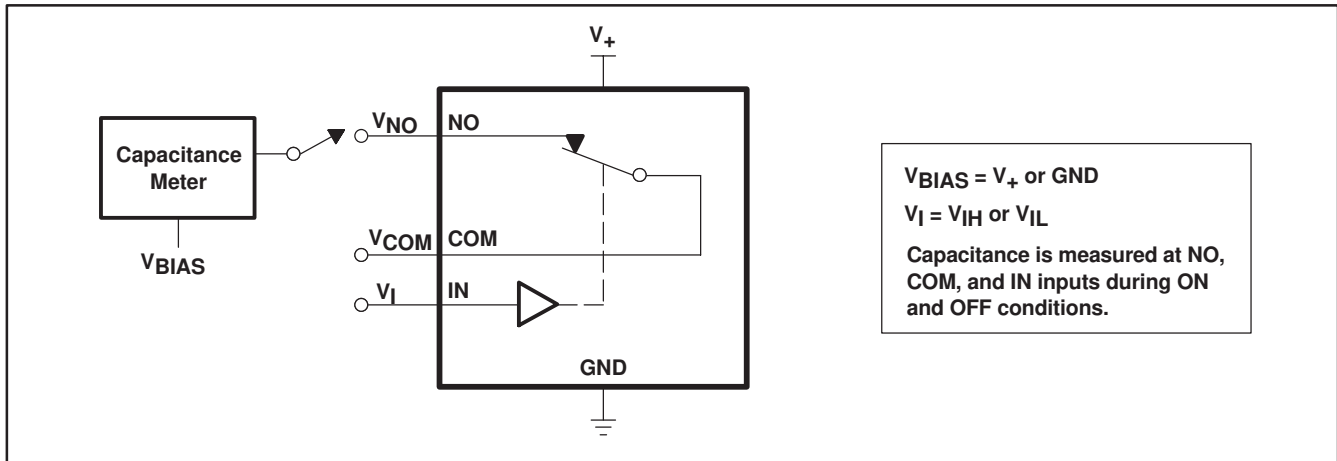
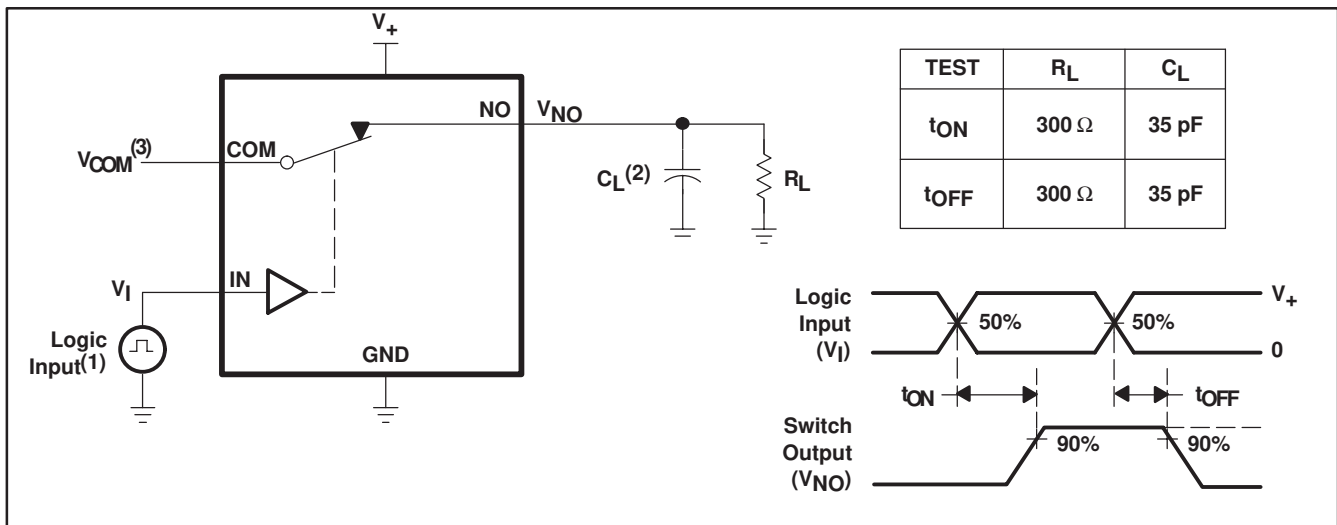

Figure 16. Capacitance (C_I , $C_{COM(OFF)}$, $C_{COM(ON)}$, $C_{NO(OFF)}$, $C_{NO(ON)}$)



- (1) All input pulses are supplied by generators having the following characteristics: PRR \leq 10 MHz, $Z_O = 50 \Omega$, $t_r < 5$ ns, $t_f < 5$ ns.
 (2) C_L includes probe and jig capacitance.
 (3) See Electrical Characteristics for V_{COM} .

Figure 17. Turn-On (t_{ON}) and Turn-Off Time (t_{OFF})

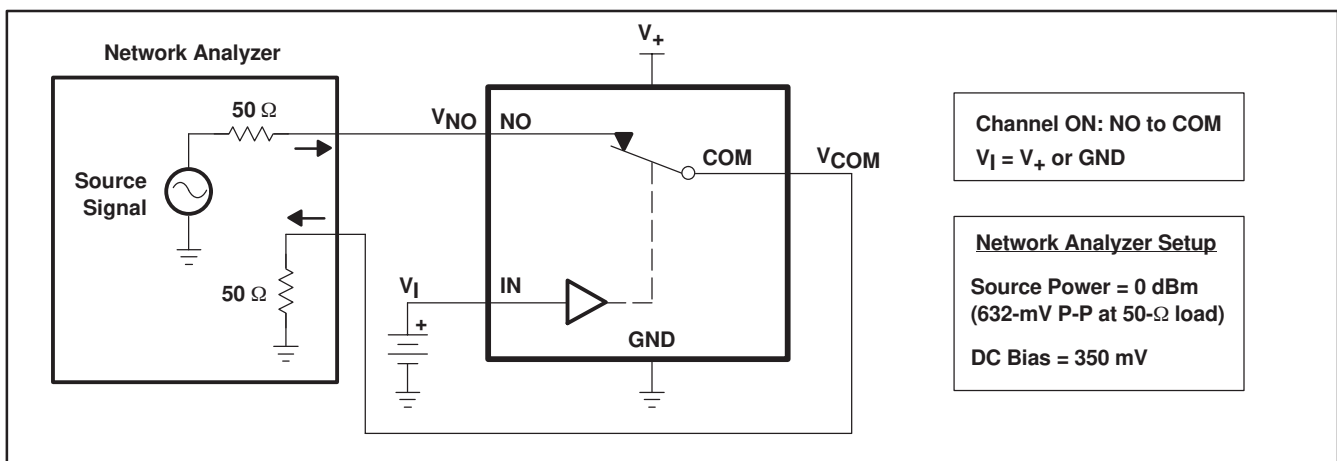

Figure 18. Bandwidth (BW)

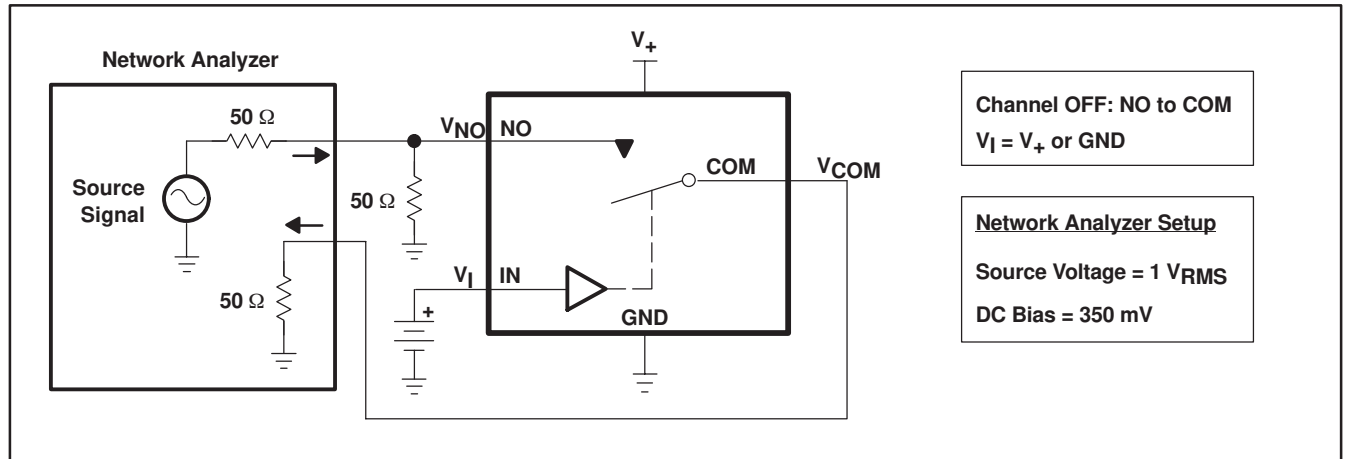
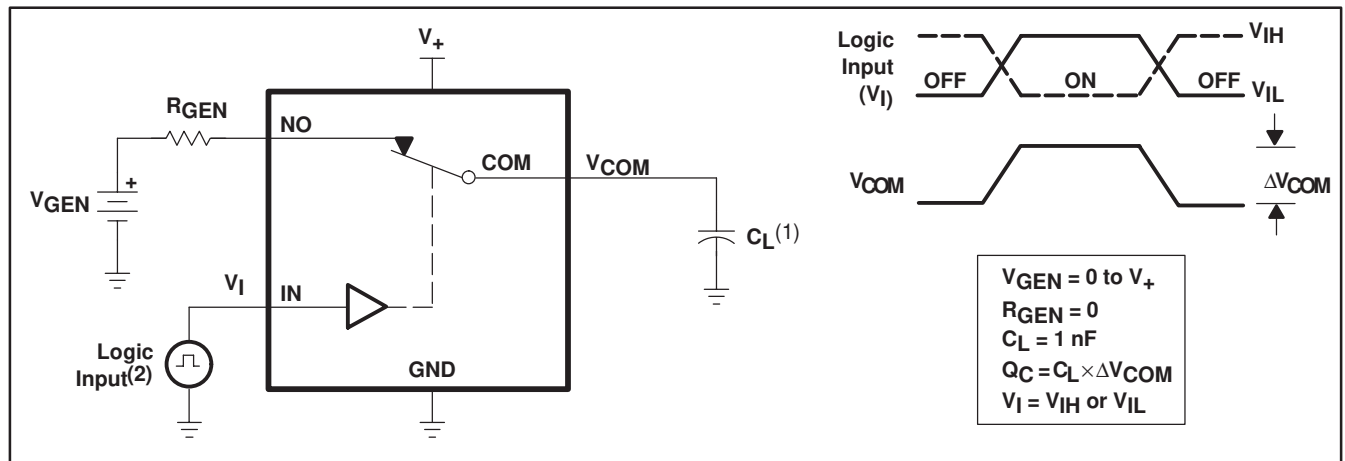

Figure 19. OFF Isolation (O_{ISO})



(1) C_L includes probe and jig capacitance.

(2) All input pulses are supplied by generators having the following characteristics: $PRR \leq 10$ MHz, $Z_O = 50 \Omega$, $t_r < 5$ ns, $t_f < 5$ ns.

Figure 20. Charge Injection (Q_C)

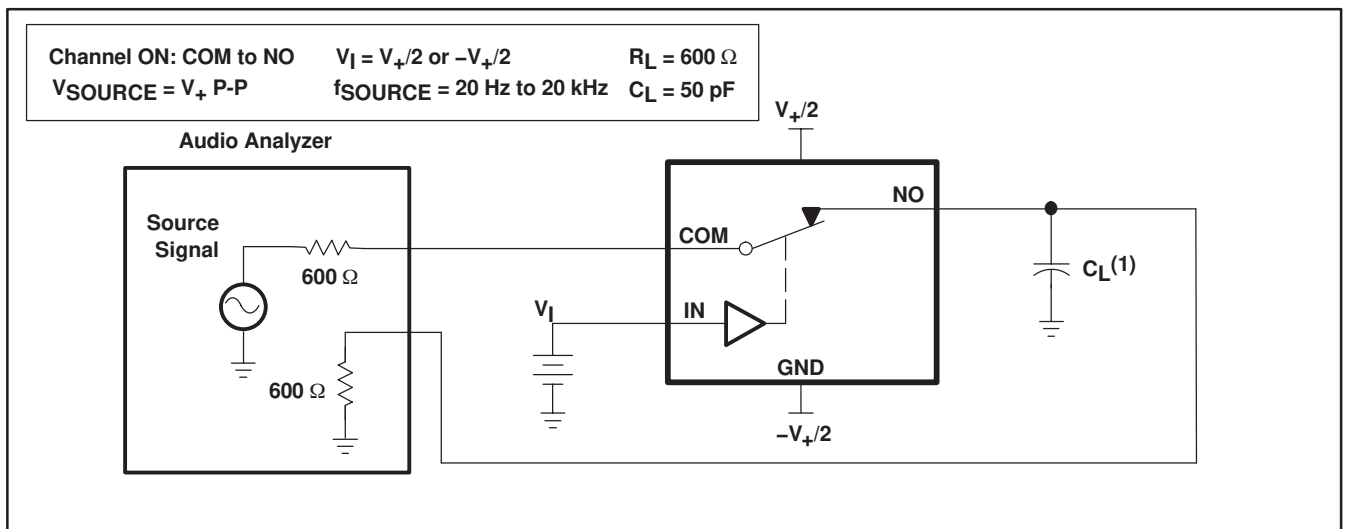

(1) C_L includes probe and jig capacitance.

Figure 21. Total Harmonic Distortion (THD)

PACKAGING INFORMATION

Orderable Device	Status (1)	Package Type	Package Drawing	Pins	Package Qty	Eco Plan (2)	Lead finish/ Ball material (6)	MSL Peak Temp (3)	Op Temp (°C)	Device Marking (4/5)	Samples
MAX4596DBVR	ACTIVE	SOT-23	DBV	5	3000	RoHS & Green	NIPDAU	Level-1-260C-UNLIM	-40 to 85	6SCR	Samples
MAX4596DCKR	ACTIVE	SC70	DCK	5	3000	RoHS & Green	NIPDAU	Level-1-260C-UNLIM	-40 to 85	SCR	Samples

(1) The marketing status values are defined as follows:

ACTIVE: Product device recommended for new designs.

LIFEBUY: TI has announced that the device will be discontinued, and a lifetime-buy period is in effect.

NRND: Not recommended for new designs. Device is in production to support existing customers, but TI does not recommend using this part in a new design.

PREVIEW: Device has been announced but is not in production. Samples may or may not be available.

OBSOLETE: TI has discontinued the production of the device.

(2) **RoHS:** TI defines "RoHS" to mean semiconductor products that are compliant with the current EU RoHS requirements for all 10 RoHS substances, including the requirement that RoHS substance do not exceed 0.1% by weight in homogeneous materials. Where designed to be soldered at high temperatures, "RoHS" products are suitable for use in specified lead-free processes. TI may reference these types of products as "Pb-Free".

RoHS Exempt: TI defines "RoHS Exempt" to mean products that contain lead but are compliant with EU RoHS pursuant to a specific EU RoHS exemption.

Green: TI defines "Green" to mean the content of Chlorine (Cl) and Bromine (Br) based flame retardants meet JS709B low halogen requirements of <=1000ppm threshold. Antimony trioxide based flame retardants must also meet the <=1000ppm threshold requirement.

(3) MSL, Peak Temp. - The Moisture Sensitivity Level rating according to the JEDEC industry standard classifications, and peak solder temperature.

(4) There may be additional marking, which relates to the logo, the lot trace code information, or the environmental category on the device.

(5) Multiple Device Markings will be inside parentheses. Only one Device Marking contained in parentheses and separated by a "~" will appear on a device. If a line is indented then it is a continuation of the previous line and the two combined represent the entire Device Marking for that device.

(6) Lead finish/Ball material - Orderable Devices may have multiple material finish options. Finish options are separated by a vertical ruled line. Lead finish/Ball material values may wrap to two lines if the finish value exceeds the maximum column width.

Important Information and Disclaimer:The information provided on this page represents TI's knowledge and belief as of the date that it is provided. TI bases its knowledge and belief on information provided by third parties, and makes no representation or warranty as to the accuracy of such information. Efforts are underway to better integrate information from third parties. TI has taken and continues to take reasonable steps to provide representative and accurate information but may not have conducted destructive testing or chemical analysis on incoming materials and chemicals. TI and TI suppliers consider certain information to be proprietary, and thus CAS numbers and other limited information may not be available for release.

In no event shall TI's liability arising out of such information exceed the total purchase price of the TI part(s) at issue in this document sold by TI to Customer on an annual basis.

TAPE AND REEL BOX DIMENSIONS

*All dimensions are nominal

Device	Package Type	Package Drawing	Pins	SPQ	Length (mm)	Width (mm)	Height (mm)
MAX4596DBVR	SOT-23	DBV	5	3000	202.0	201.0	28.0
MAX4596DCKR	SC70	DCK	5	3000	202.0	201.0	28.0

EXAMPLE BOARD LAYOUT

DCK0005A

SOT - 1.1 max height

SMALL OUTLINE TRANSISTOR

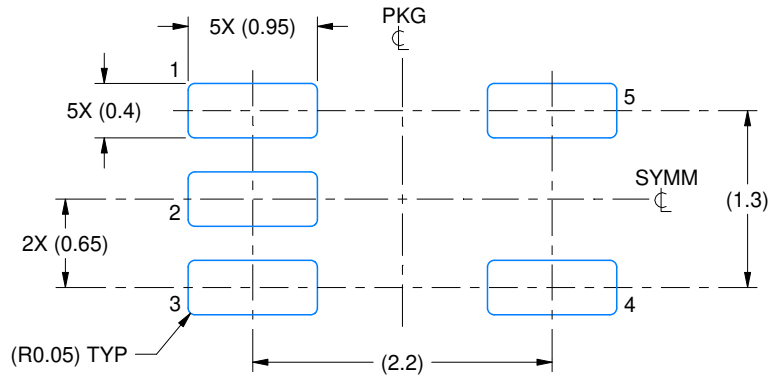

LAND PATTERN EXAMPLE
EXPOSED METAL SHOWN
SCALE:18X

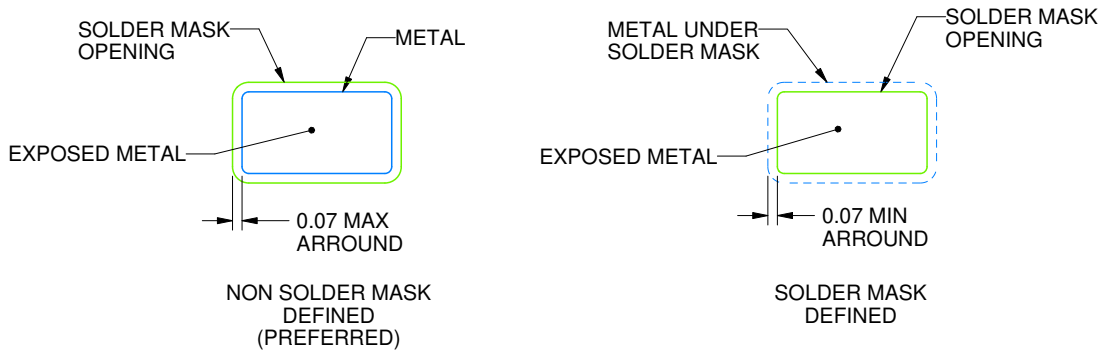

SOLDER MASK DETAILS

4214834/C 03/2023

NOTES: (continued)

- 4. Publication IPC-7351 may have alternate designs.
- 5. Solder mask tolerances between and around signal pads can vary based on board fabrication site.

EXAMPLE STENCIL DESIGN

DCK0005A

SOT - 1.1 max height

SMALL OUTLINE TRANSISTOR

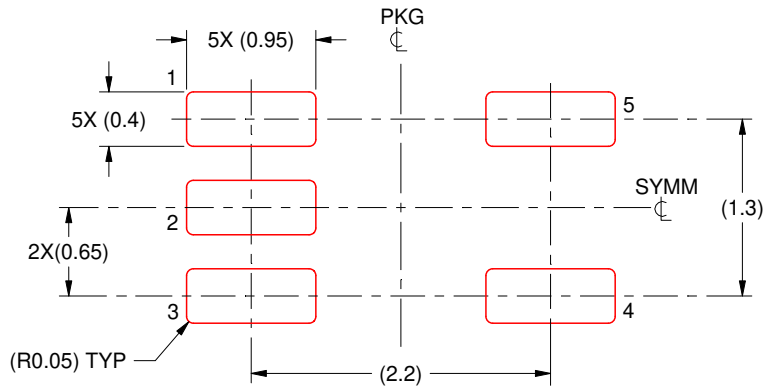

SOLDER PASTE EXAMPLE
BASED ON 0.125 THICK STENCIL
SCALE:18X

4214834/C 03/2023

NOTES: (continued)

6. Laser cutting apertures with trapezoidal walls and rounded corners may offer better paste release. IPC-7525 may have alternate design recommendations.
7. Board assembly site may have different recommendations for stencil design.

EXAMPLE BOARD LAYOUT

DBV0005A

SOT-23 - 1.45 mm max height

SMALL OUTLINE TRANSISTOR

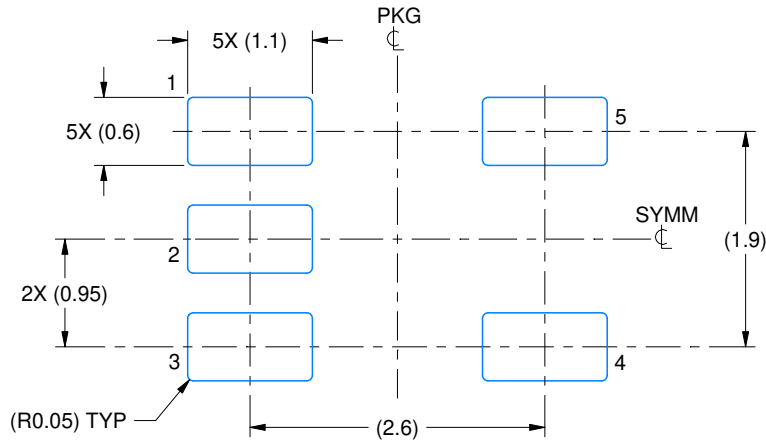

LAND PATTERN EXAMPLE
EXPOSED METAL SHOWN
SCALE:15X

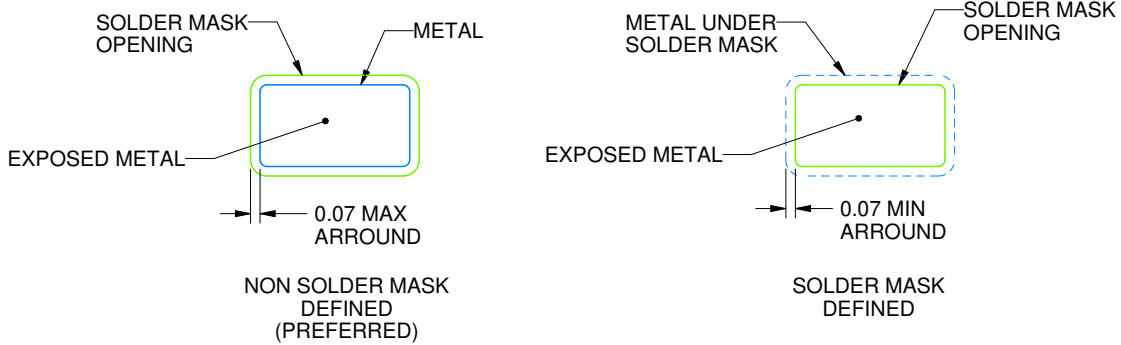

SOLDER MASK DETAILS

4214839/H 09/2023

NOTES: (continued)

- 6. Publication IPC-7351 may have alternate designs.
- 7. Solder mask tolerances between and around signal pads can vary based on board fabrication site.

EXAMPLE STENCIL DESIGN

DBV0005A

SOT-23 - 1.45 mm max height

SMALL OUTLINE TRANSISTOR



SOLDER PASTE EXAMPLE
BASED ON 0.125 mm THICK STENCIL
SCALE:15X

4214839/H 09/2023

NOTES: (continued)

8. Laser cutting apertures with trapezoidal walls and rounded corners may offer better paste release. IPC-7525 may have alternate design recommendations.
9. Board assembly site may have different recommendations for stencil design.

IMPORTANT NOTICE AND DISCLAIMER

TI PROVIDES TECHNICAL AND RELIABILITY DATA (INCLUDING DATA SHEETS), DESIGN RESOURCES (INCLUDING REFERENCE DESIGNS), APPLICATION OR OTHER DESIGN ADVICE, WEB TOOLS, SAFETY INFORMATION, AND OTHER RESOURCES "AS IS" AND WITH ALL FAULTS, AND DISCLAIMS ALL WARRANTIES, EXPRESS AND IMPLIED, INCLUDING WITHOUT LIMITATION ANY IMPLIED WARRANTIES OF MERCHANTABILITY, FITNESS FOR A PARTICULAR PURPOSE OR NON-INFRINGEMENT OF THIRD PARTY INTELLECTUAL PROPERTY RIGHTS.

These resources are intended for skilled developers designing with TI products. You are solely responsible for (1) selecting the appropriate TI products for your application, (2) designing, validating and testing your application, and (3) ensuring your application meets applicable standards, and any other safety, security, regulatory or other requirements.

These resources are subject to change without notice. TI grants you permission to use these resources only for development of an application that uses the TI products described in the resource. Other reproduction and display of these resources is prohibited. No license is granted to any other TI intellectual property right or to any third party intellectual property right. TI disclaims responsibility for, and you will fully indemnify TI and its representatives against, any claims, damages, costs, losses, and liabilities arising out of your use of these resources.

TI's products are provided subject to [TI's Terms of Sale](#) or other applicable terms available either on [ti.com](https://www.ti.com) or provided in conjunction with such TI products. TI's provision of these resources does not expand or otherwise alter TI's applicable warranties or warranty disclaimers for TI products.

TI objects to and rejects any additional or different terms you may have proposed.

Mailing Address: Texas Instruments, Post Office Box 655303, Dallas, Texas 75265
Copyright © 2023, Texas Instruments Incorporated