

# 3mm (T1) Package Discrete LED RED, Low Current

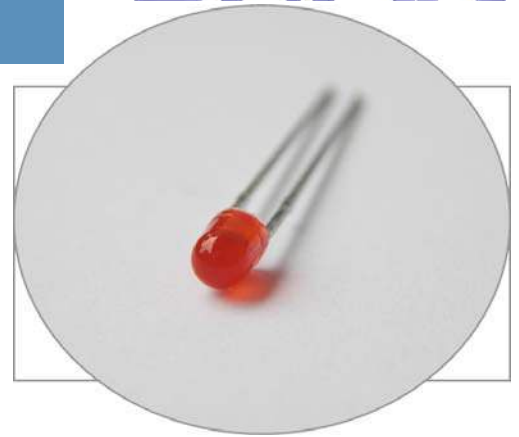

## 3HDL-X

- ◆ Industry Standard 3mm (T1) Package
- ◆ RoHS Compliant
- ◆ Diffused Lens
- ◆ Available in Flange (F) and Shouldered (S) Lead Frame Styles
- ◆ 2 mA Low Operating Current
- ◆ Ideal for Status Indication and Display

Bivar 3mm T1 Package 2 mA Low Current LED is special binned at 2 mA and is ideal for those applications where lower power budget is required such as solar panel or battery-powered portable devices. Bivar offers diffused LED lens for uniform light output. The Flanged LED is ideal for Panel Mount Clip & Ring assemblies. The Shouldered Lead frame LED is ideal for vertical spacer assemblies without lead bends and also has a built in strain relief feature which is ideal for right angle holder assemblies that require lead bends.

Part Number	Material	Emitted Color	Peak. Wavelength $\lambda_p$ (nm) TYP.	Lens Appearance	Viewing Angle
3HDL-F	GaAsP/GaP	RED	625nm	Red Diffused	35°
3HDL-S				Red Diffused	40°

## Part Number Designation

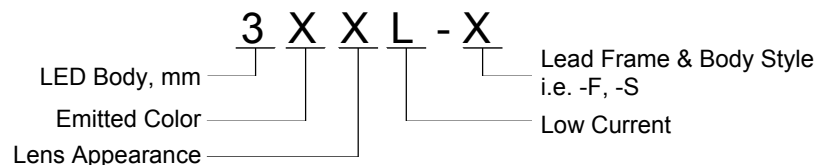

Bivar reserves the right to make changes at any time without notice.

# 3mm (T1) Package Discrete LED RED, Low Current



## Outline Dimensions

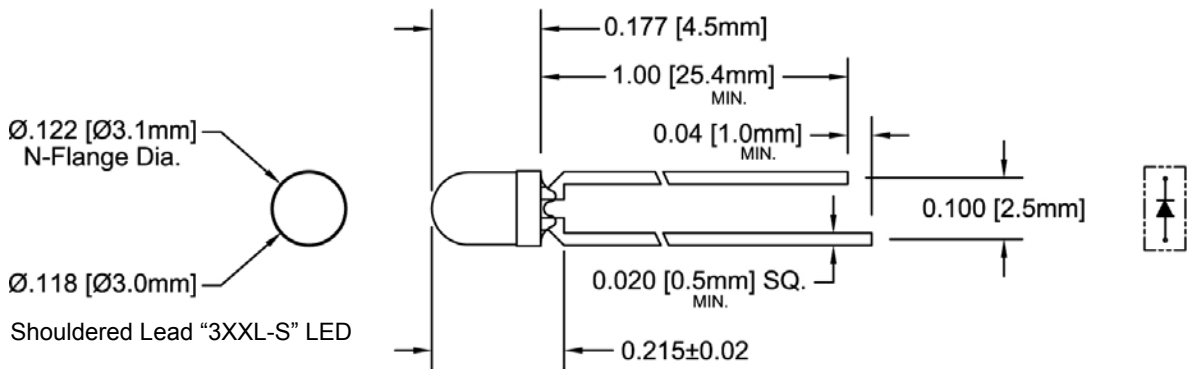
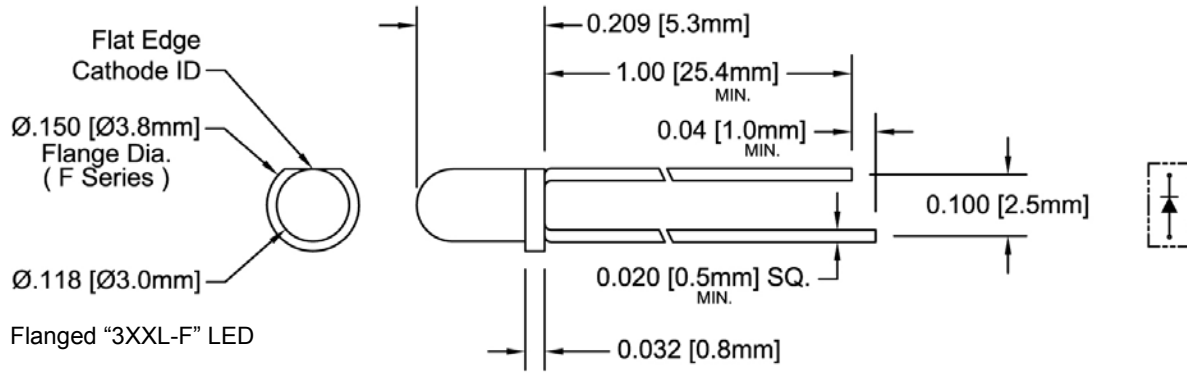

**Recommended Mounting**  
Hole Size =  $\text{Ø}0.032^{+0.003}_{-0.002}$

### Outline Drawings Notes:

1. All dimensions are in inches [millimeters].
2. Standard tolerance:  $\pm 0.010$ " unless otherwise noted.
3. Tolerance of overall epoxy outline:  $\pm 0.020$ " unless otherwise noted.
4. Epoxy meniscus may extend to 0.060" max.

Bivar reserves the right to make changes at any time without notice.

# 3mm (T1) Package Discrete LED RED, Low Current



## Absolute Maximum Ratings

T<sub>A</sub> = 25°C unless otherwise noted

Power Dissipation	10 mW
Forward Current ( DC )	7 mA
Peak Forward Current <sup>1</sup>	/ mA
Reverse Voltage	5 V
Operating Temperature Range	-25 ~ +85°C
Storage Temperature Range	-30 ~ +100°C
Lead Soldering Temperature ( 3 mm from the base of the epoxy bulb ) <sup>2</sup>	260°C

Notes: 1. 10% Duty Cycle, Pulse Width ≤ 0.1 msec.      2. Solder time less than 5 seconds at temperature extreme.

## Electrical / Optical Characteristics

T<sub>A</sub> = 25°C & I<sub>F</sub> = 2 mA unless otherwise noted

Part Number	Forward Voltage (V) <sup>1</sup>			Recommend Forward Current (mA)			Reverse Current (μA)	Dominant Wavelength (nm) <sup>2</sup>			Luminous Intensity I <sub>v</sub> (mcd)			Viewing Angle 2Θ ½ (deg)
	MIN	TYP	MAX	MIN	TYP	MAX	MAX	MIN	TYP	MAX	MIN	TYP	MAX	TYP
3HDL-F	/	2.0	2.6	/	2	/	100	/	/	/	/	2.5	/	35
3HDL-S	/	2.0	2.6	/	2	/	100	/	/	/	/	2.5	/	40

Notes: 1. Tolerance of forward voltage : ±0.05V.      2. Tolerance of dominant wavelength : ±1.0nm.

Bivar reserves the right to make changes at any time without notice.

# 3mm (T1) Package Discrete LED RED, Low Current



## Typical Electrical / Optical Characteristics

$T_A = 25^\circ\text{C}$  unless otherwise noted

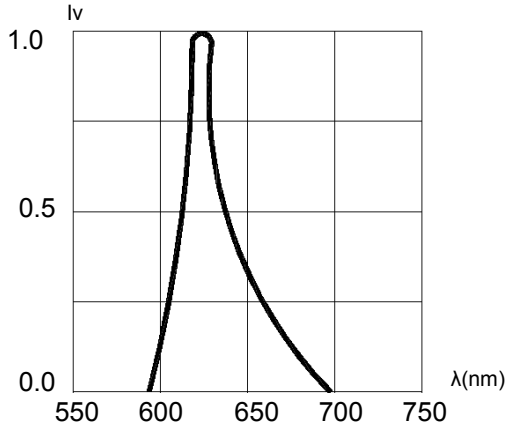

Fig. 1 Relative Luminous Intensity vs. Wavelength

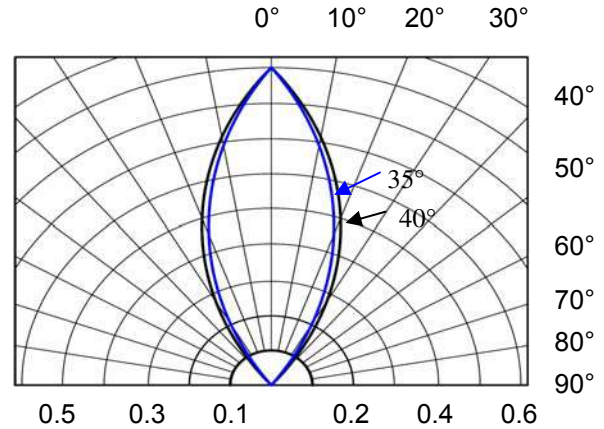

Fig. 2 Directivity Radiation Diagram



Fig. 3 Relative Intensity (10mA) vs. Forward Voltage

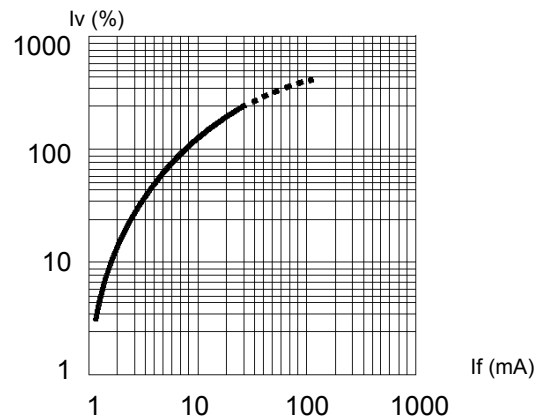

Fig. 4 Relative Luminous Intensity (%) vs. Forward Current

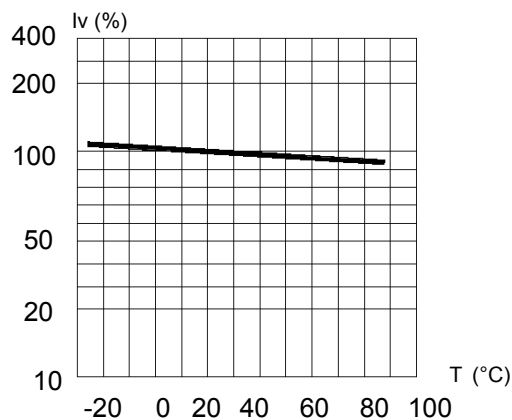

Fig. 5 Relative Intensity (%) vs. Temperature  
@ 20 mA

Bivar reserves the right to make changes at any time without notice.

# 3mm (T1) Package Discrete LED RED, Low Current



## Recommended Soldering Conditions

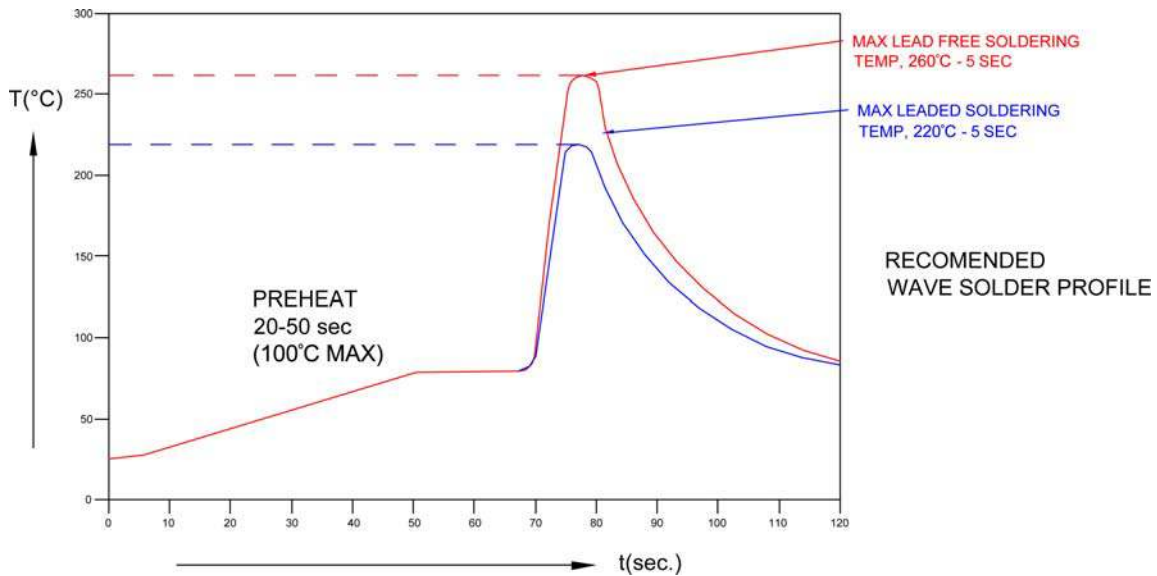

Recommended Lead Free Wave Soldering Profile	
Preheat Temperature: 100°C Max.	Peak Temperature: 260°C Max.
Preheat Time: 20 ~ 50 Seconds	Solder Time Above 217°C: 5 Seconds Max.
Note: Turn off top heater at preheat to prevent the lamp body directly exposed to the heat source.	

## Packaging and Labeling Plan

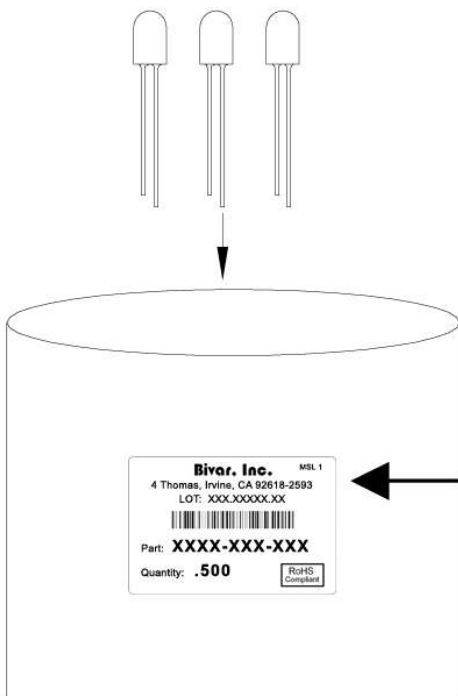

**Bivar, Inc.** MSL 1

4 Thomas, Irvine, CA 92618-2593  
LOT: XXX.XXXXX.XX



Part: **XXXX-XXX-XXX**

Quantity: **.500**

RoHS  
Compliant

Anti-Static Poly Bag with Desiccant  
(500 pcs Max. per Bag)

Bivar reserves the right to make changes at any time without notice.