

SLIN-30E1AL

Non-Isolated DC-DC Converter

The SLIN-30E1AL power module is non-isolated dc-dc converter that can deliver up to 30 A of output current. This module operates over a wide range of input voltage ($V_{IN} = 6 - 14$ VDC) and provides a precisely regulated output voltage from 0.8 VDC to 3.63 VDC, programmable via an external resistor.

Features include remote on/off, adjustable output voltage, over current and over temperature protection, output voltage sequencing and paralleling with active current sharing. A new feature, the Tunable Loop™, allows the user to optimize the dynamic response of the converter to match the load with reduced amount of output capacitance leading to savings on cost and PWB area.



Key Features & Benefits

- Wide Input Voltage Range
- High Efficiency
- Monotonic Start-up
- Remote On/Off
- Remote Sense
- Output Voltage Sequencing
- Over Temperature Protection
- Output Over Current Protection
- Startup into Pre-biased Output
- Tunable Loop™ (a Registered Trademark of Lineage Power Systems) to Optimize Dynamic Output Voltage Response
- Parallel Operation with Active Current Sharing
- Class II, Category 2, Non-Isolated DC/DC Converter (refer to IPC-9592B)
- Certificated to UL/CSA 62368-1



Applications

- Distributed Power Architectures
- Servers and Storage Applications
- Intermediate Bus Voltage Applications
- Networking Equipment
- Telecommunications Equipment

1. MODEL SELECTION

MODEL NUMBER	OUTPUT VOLTAGE	INPUT VOLTAGE	MAX. OUTPUT CURRENT	TYPICAL EFFICIENCY
SLIN-30E1ALG	0.8 - 3.63 VDC	6.0 - 14 VDC	30 A	92.9%
SLIN-30E1ALR				

PART NUMBER EXPLANATION

S	LIN	-	30	E	1A	L	x
Mounting Type	Series Code		Output Current	Input Voltage Range	Sequencing or not	Active Logic	Package
Surface Mount	SLIN Series		30 A	6.0 - 14 V	With Sequencing	Active Low	G – Tray Package R – Tape and Reel Package

2. ABSOLUTE MAXIMUM RATINGS

PARAMETER	DESCRIPTION	MIN	TYP	MAX	UNITS
Continuous Input Voltage		-0.3	-	15	V
Sequencing Voltage		-0.3	-	15	V
Operating Ambient Temperature		-40	-	85	°C
Storage Temperature		-55	-	125	°C
Altitude		-	-	2000	m

NOTE: Stresses in excess of the absolute maximum ratings can cause permanent damage to the device. These are absolute stress ratings only, functional operation of the device is not implied at these or any other conditions in excess of those given in the operations sections of the data sheet. Exposure to absolute maximum ratings for extended periods can adversely affect the device reliability.

3. INPUT SPECIFICATIONS

PARAMETER	DESCRIPTION	MIN	TYP	MAX	UNIT
Operating Input Voltage		6.0	12	14	V
Input Current (full load)	$V_{IN} = V_{IN,min}$, $V_O = V_{O,set}$, $I_O = I_{O,max}$	-	-	19	A
Input Current (no load)	$V_O = 0.8$ V, $V_{IN} = 12$ V, $I_O = 0$, module enabled	-	91	-	mA
	$V_O = 3.3$ V, $V_{IN} = 12$ V, $I_O = 0$, module enabled	-	265	-	mA
Input Stand-by Current	$V_{IN} = 12$ V, module disabled	-	20	-	mA
Input Reflected Ripple Current (pk-pk)	5 Hz to 20 MHz, 1 μ H source impedance; $V_{IN} = 6.0$ to 14 V, $I_O = I_{O,max}$	-	100	-	mA
I^2t Inrush Current Transient		-	-	1	A ² s
Input Ripple Rejection (120 Hz)		-	50	-	dB
Turn-on Threshold		-	5.5	-	V
Turn-off Threshold		-	5.0	-	V

CAUTION: This converter is not internally fused. An input line fuse must be used in application.

This power module can be used in a wide variety of applications, ranging from simple standalone operation to an integrated part of sophisticated power architecture. To preserve maximum flexibility, internal fusing is not included; however, to achieve maximum safety and system protection, always use an input line fuse. The safety agencies require a time-delay fuse with a maximum rating of 30A in the ungrounded input lead. Refer to the fuse manufacturer's data sheet for further information.

NOTE: Unless otherwise indicated, specifications apply over entire operating input voltage range, resistive load, and temperature conditions.

4. OUTPUT SPECIFICATIONS

PARAMETER	DESCRIPTION	MIN	TYP	MAX	UNIT	
Output Voltage Set Point	$V_{IN} = V_{IN,nom}$, $I_O = I_{O,nom}$, $T_{ref} = 25^{\circ}C$.	-1.5	-	+1.5	% $V_{O,set}$	
Output Voltage	Over entire operating input voltage range, resistive load, and temperature conditions until end of life	-3.0	-	+3.0	% $V_{O,set}$	
Adjustment Range	Selected by an external resistor	0.8	-	3.63	V	
Remote Sense Range		-	-	0.5	V	
Load Regulation	$I_O = I_{O,min}$ to $I_{O,max}$	-	-	10	mV	
Line Regulation	$V_{IN} = V_{IN,min}$ to $V_{IN,max}$	-	-	10	mV	
Temperature Regulation (-40°C to 85°C)	$T_{ref} = T_{A,min}$ to $T_{A,max}$	-	0.5	1	% $V_{O,set}$	
Output Current Range		0	-	30	A	
Output DC Current Limit	Hiccup Mode	-	140	-	% $I_{O,max}$	
Ripple and Noise (pk-pk)	5 Hz to 20 MHz BW, $V_{IN} = V_{IN,nom}$ and $I_O = I_{O,min}$ to $I_{O,max}$, $C_O = 0.1 \mu F // 47 \mu F$ ceramic capacitors	-	-	50	mV	
Output Short-Circuit Current	$V_O \leq 250$ mV, Hiccup Mode	-	3.5	-	A	
Turn-On Delay Time	Case 1: On/Off input is enabled and then input power is applied (delay from instant at which $V_{IN} = V_{IN,min}$ until $V_O = 10\%$ of $V_{O,set}$)	-	2.5	5	ms	
	Case 2: Input power is applied for at least one second and then the On/Off input is enabled (delay from instant at which Von/Off is enabled until $V_O = 10\%$ of $V_{O,set}$)	-	2.5	5	ms	
Output Voltage Overshoot	$V_{in} = V_{in,min}$ to $V_{in,max}$, $I_O = I_{O,max}$, $T_a = 25^{\circ}C$ With or without maximum external capacitance	-	-	3	% $V_{O,set}$	
Output Voltage Rise Time	Time for V_O to rise from 10% of $V_{O,set}$ to 90% of $V_{O,set}$	2	-	10	ms	
Output Capacitance	ESR ≥ 1 m Ω	Without the Tunable Loop™	0	-	200	
	ESR ≥ 0.15 m Ω	With the Tunable Loop™	0	-	1000	μF
	ESR ≥ 10 m Ω	With the Tunable Loop™	0	-	10000	

NOTE: Unless otherwise indicated, specifications apply over entire operating input voltage range, resistive load, and temperature conditions.

5. GENERAL SPECIFICATIONS

PARAMETER	DESCRIPTION	MIN	TYP	MAX	UNIT
Efficiency	Vo = 0.8 V	-	83.0	-	%
	Vo = 1.2 V	-	87.1	-	
	Vo = 1.8 V	-	90.1	-	
	Vo = 2.5 V	-	91.8	-	
	Vo = 3.3 V	-	92.9	-	
Switching Frequency		-	300	-	kHz
Over Temperature Protection		-	125	-	°C
Sequencing Slew Rate Capability	V _{IN, min} to V _{IN, max} ; I _{o, min} to I _{o, max} VSEQ < Vo	-	-	2	V/ms
Sequencing Delay Time	Delay from V _{IN, min} to application of voltage on SEQ pin	10	-	-	ms
Tracking Accuracy	Power-Up: 2 V/ms	-	100	200	mV
	Power-Down: 1 V/ms	-	200	400	
Forced Load Share Accuracy		-	10	-	%I _o
Number of Units in Parallel		-	-	5	-
Weight		-	7.04	-	g
MTBF	Calculated MTBF (V _{in} = 12 V, I _o = 80% full load, V _o = 2.5 V, T _a =40°C, 200 LFM) per Telecordia Method Issue 2, Method I Case 3		4,443,300		hours
Dimensions (L × W × H)			1.30 × 0.53 × 0.40		inch
			33.02 × 13.46 × 10.16		mm

NOTE: Unless otherwise indicated, specifications apply over entire operating input voltage range, resistive load, and temperature condition.

6. EFFICIENCY DATA

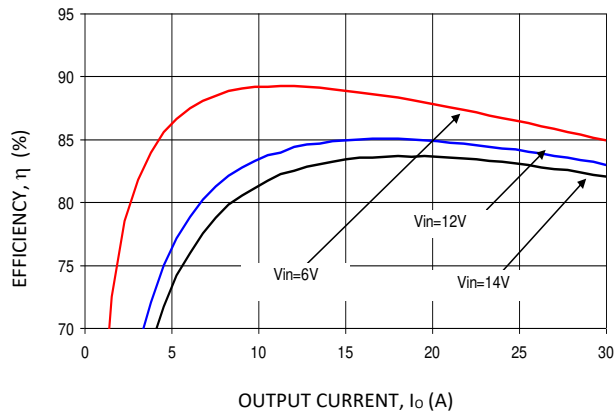

Figure 1. $V_o = 0.8\text{ V}$, $T_a = 25^\circ\text{C}$

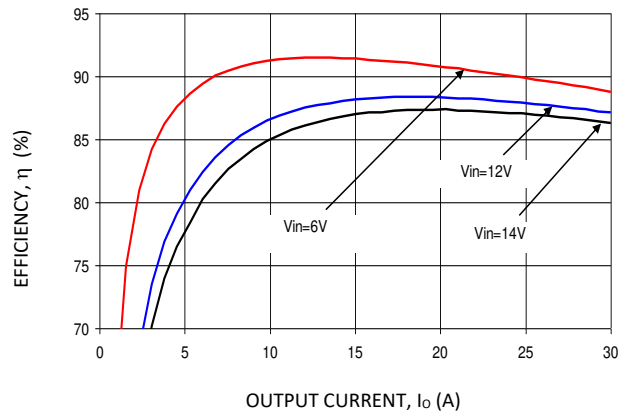

Figure 2. $V_o = 1.2\text{ V}$, $T_a = 25^\circ\text{C}$

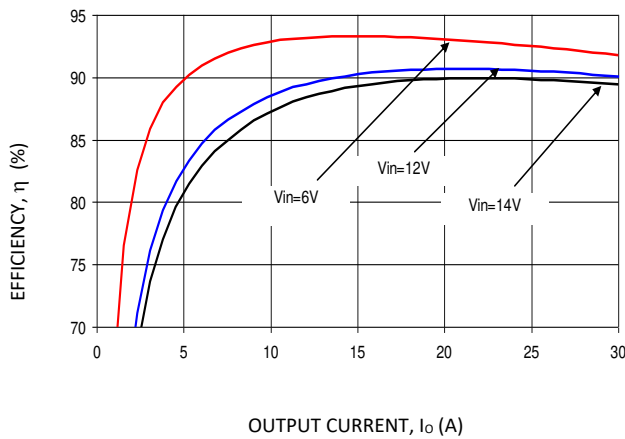

Figure 3. $V_o = 1.8\text{ V}$, $T_a = 25^\circ\text{C}$

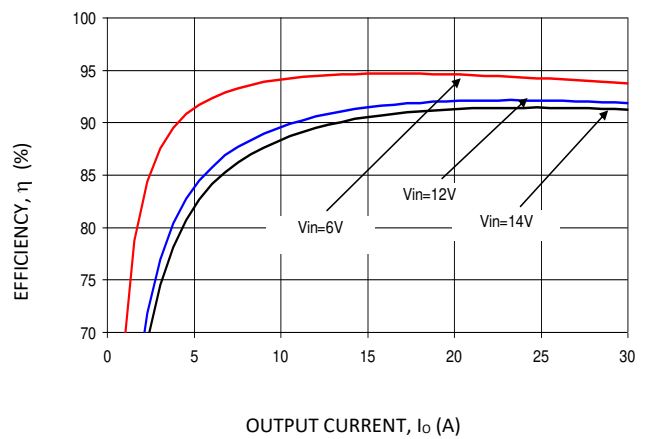

Figure 4. $V_o = 2.5\text{ V}$, $T_a = 25^\circ\text{C}$

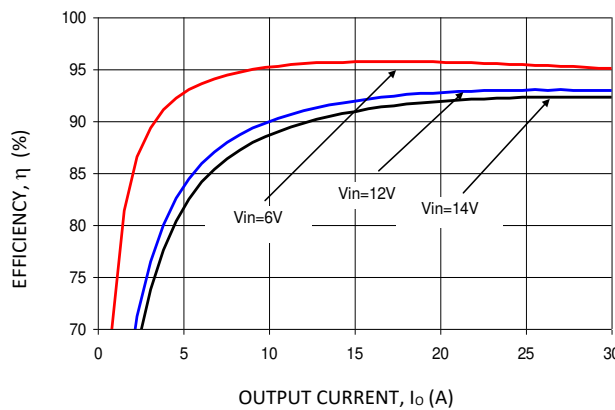

Figure 5. $V_o = 3.3\text{ V}$, $T_a = 25^\circ\text{C}$



Asia-Pacific
+86 755 298 85888

Europe, Middle East
+353 61 49 8941

North America
+1 866 513 2839

7. THERMAL DERATING CURVES

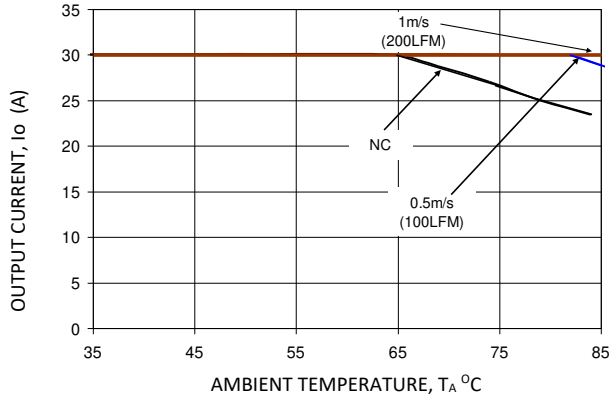

Figure 6. $V_o = 0.8 V$, $V_{in} = 12 V$

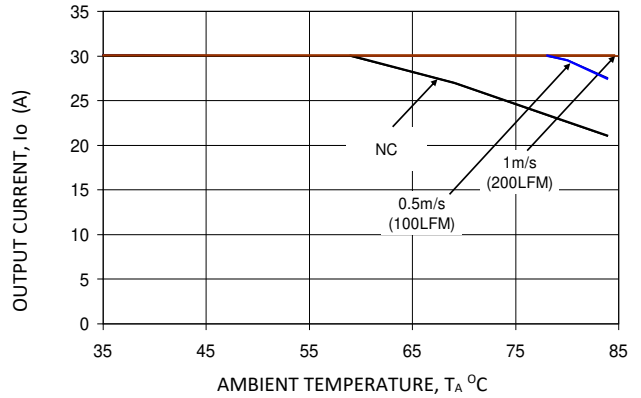

Figure 7. $V_o = 1.2 V$, $V_{in} = 12 V$

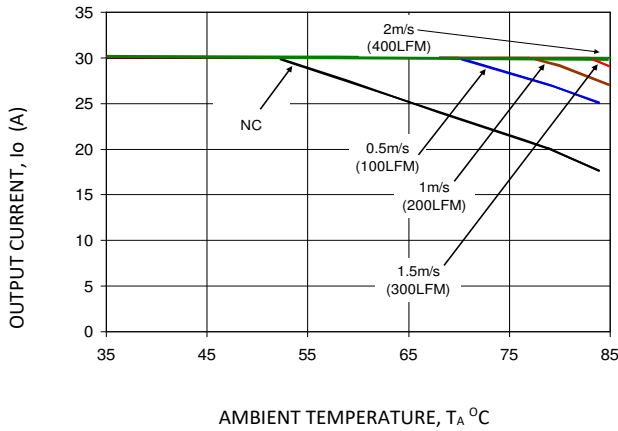

Figure 8. $V_o = 1.8 V$, $V_{in} = 12 V$

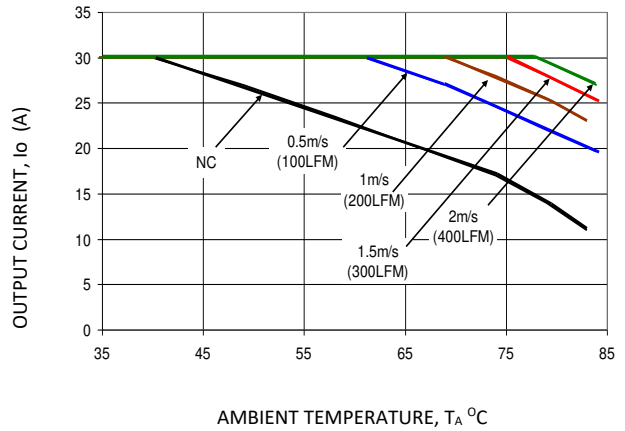

Figure 9. $V_o = 2.5 V$, $V_{in} = 12 V$

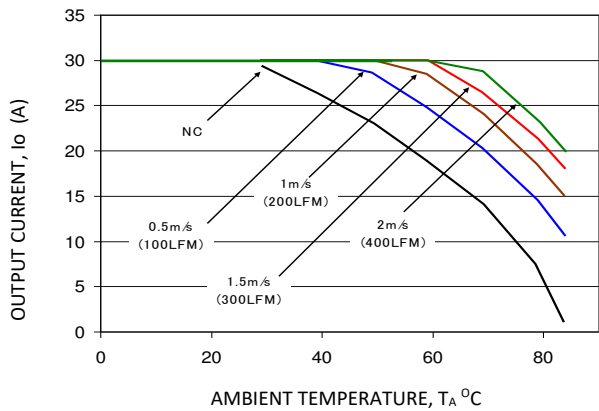

Figure 10. $V_o = 3.3 V$, $V_{in} = 12 V$

8. RIPPLE AND NOISE WAVEFORMS

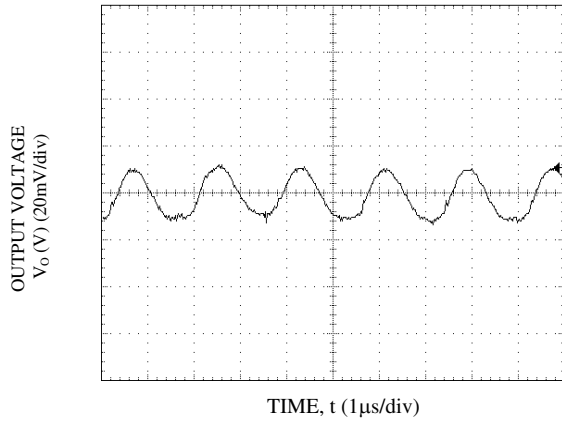

Figure 11. $V_o = 0.8\text{ V}$, $T_a = 25^\circ\text{C}$, $V_{in} = 12\text{ V}$, $I_o = I_{o,max}$
 $C_{OUT} = 0.1\ \mu\text{F} // 47\ \mu\text{F}$ ceramic capacitors

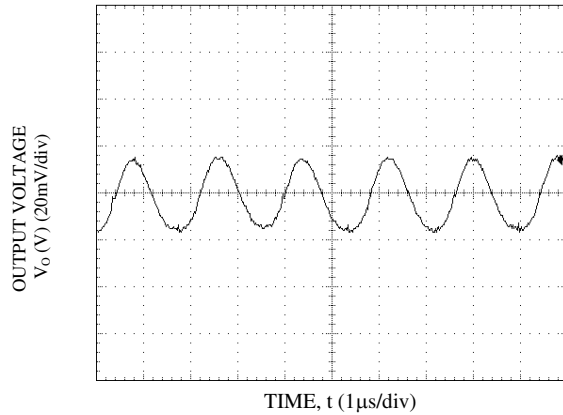

Figure 12. $V_o = 1.2\text{ V}$, $T_a = 25^\circ\text{C}$, $V_{in} = 12\text{ V}$, $I_o = I_{o,max}$
 $C_{OUT} = 0.1\ \mu\text{F} // 47\ \mu\text{F}$ ceramic capacitors

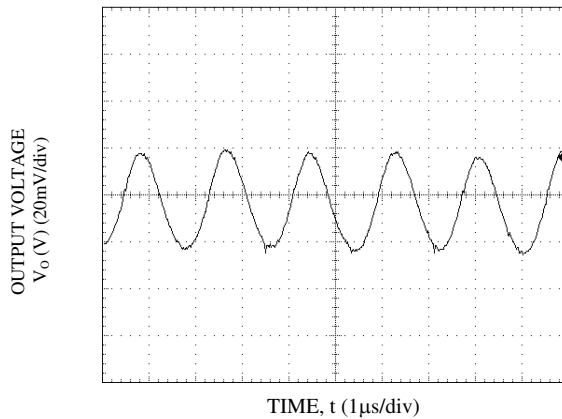

Figure 13. $V_o = 1.8\text{ V}$, $T_a = 25^\circ\text{C}$, $V_{in} = 12\text{ V}$, $I_o = I_{o,max}$
 $C_{OUT} = 0.1\ \mu\text{F} // 47\ \mu\text{F}$ ceramic capacitors

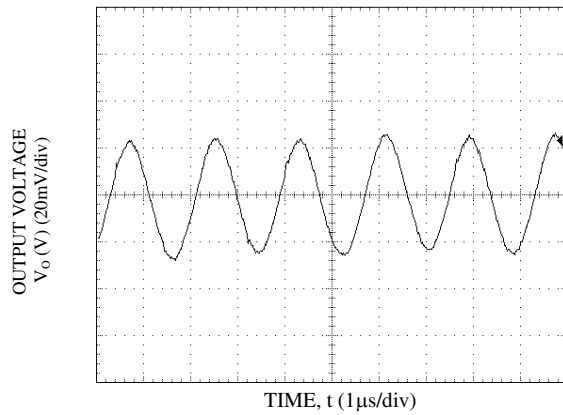

Figure 14. $V_o = 2.5\text{ V}$, $T_a = 25^\circ\text{C}$, $V_{in} = 12\text{ V}$, $I_o = I_{o,max}$
 $C_{OUT} = 0.1\ \mu\text{F} // 47\ \mu\text{F}$ ceramic capacitors

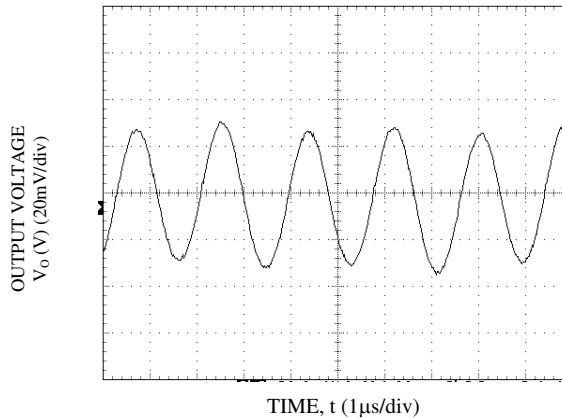

Figure 15. $V_o = 3.3\text{ V}$, $T_a = 25^\circ\text{C}$, $V_{in} = 12\text{ V}$, $I_o = I_{o,max}$
 $C_{OUT} = 0.1\ \mu\text{F} // 47\ \mu\text{F}$ ceramic capacitors

9. TRANSIENT RESPONSE WAVEFORMS

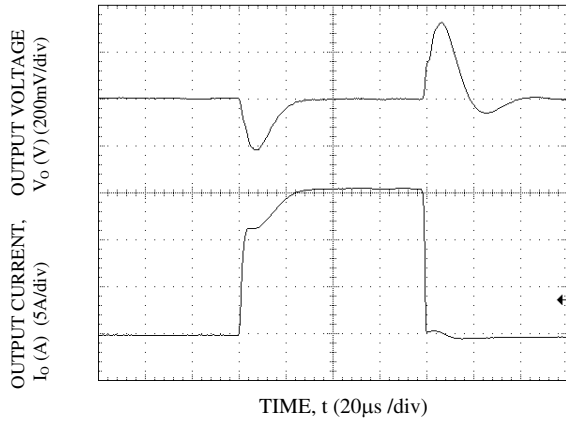

Figure 16. Transient Response to Dynamic Load Change from 0% to 50% to 0%. $V_o = 0.8\text{ V}$, $T_a = 25^\circ\text{C}$, $V_{in} = 12\text{ V}$

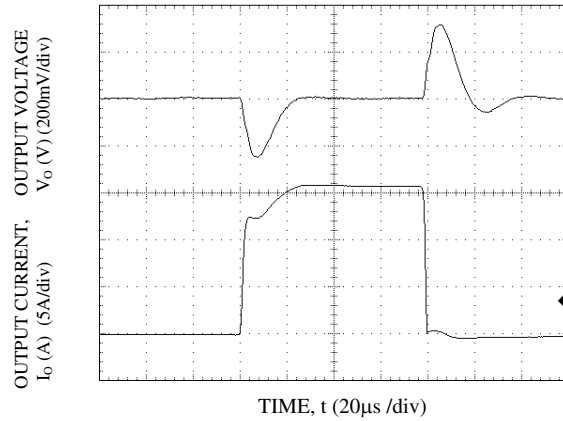

Figure 17. Transient Response to Dynamic Load Change from 0% to 50% to 0%. $V_o = 1.2\text{ V}$, $T_a = 25^\circ\text{C}$, $V_{in} = 12\text{ V}$

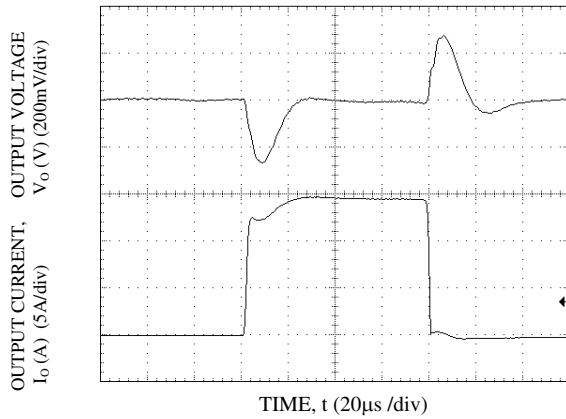

Figure 18. Transient Response to Dynamic Load Change from 0% to 50% to 0%. $V_o = 1.8\text{ V}$, $T_a = 25^\circ\text{C}$, $V_{in} = 12\text{ V}$

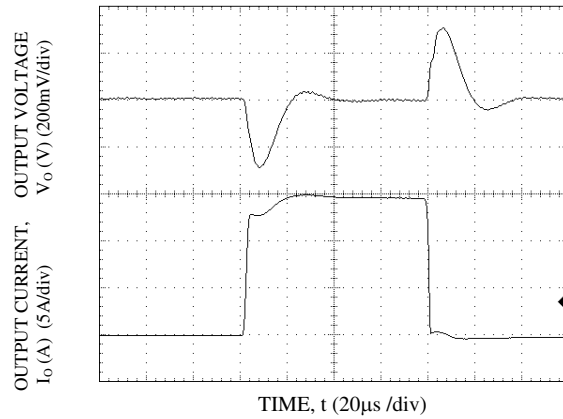

Figure 19. Transient Response to Dynamic Load Change from 0% to 50% to 0%. $V_o = 2.5\text{ V}$, $T_a = 25^\circ\text{C}$, $V_{in} = 12\text{ V}$

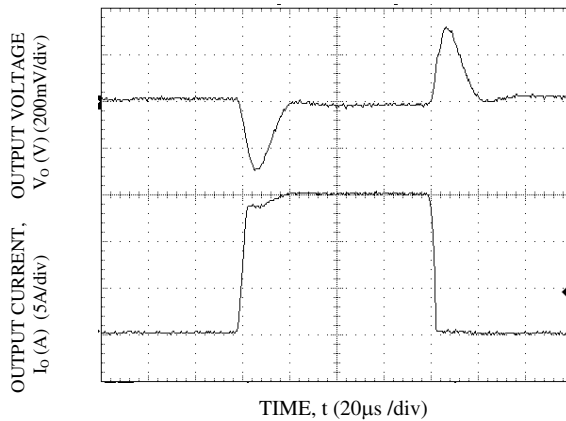

Figure 20. Transient Response to Dynamic Load Change from 0% to 50% to 0%. $V_o = 3.3\text{ V}$, $T_a = 25^\circ\text{C}$, $V_{in} = 12\text{ V}$

10. STARTUP TIME

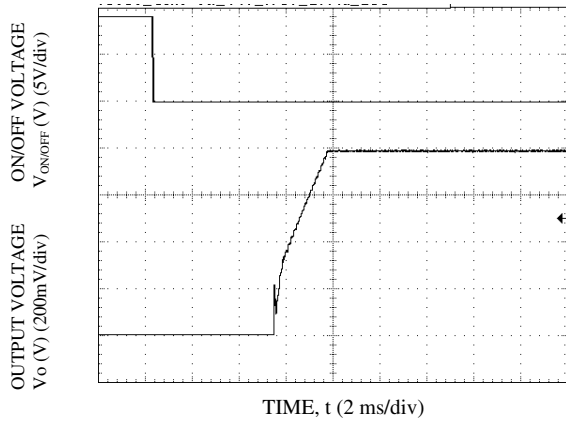

Figure 21. Start-up Using On/Off Voltage ($I_o = I_{o,max}$)
 $V_o = 0.8 V, T_a = 25^\circ C$

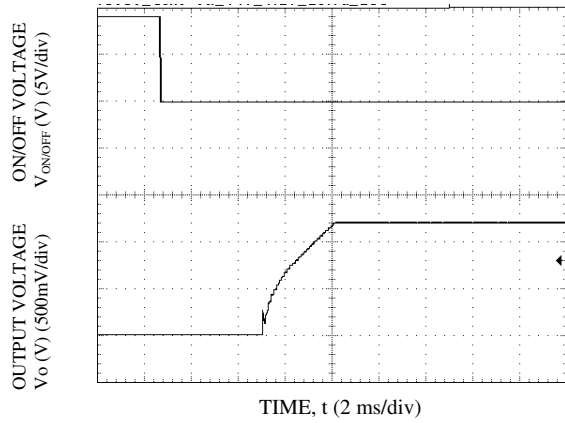

Figure 22. Start-up Using On/Off Voltage ($I_o = I_{o,max}$)
 $V_o = 1.2 V, T_a = 25^\circ C$

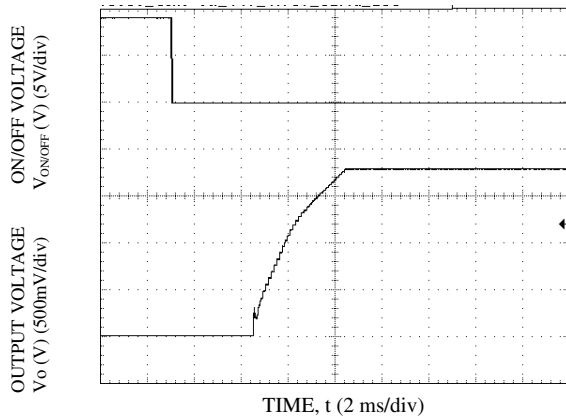

Figure 23. Start-up Using On/Off Voltage ($I_o = I_{o,max}$)
 $V_o = 1.8 V, T_a = 25^\circ C$

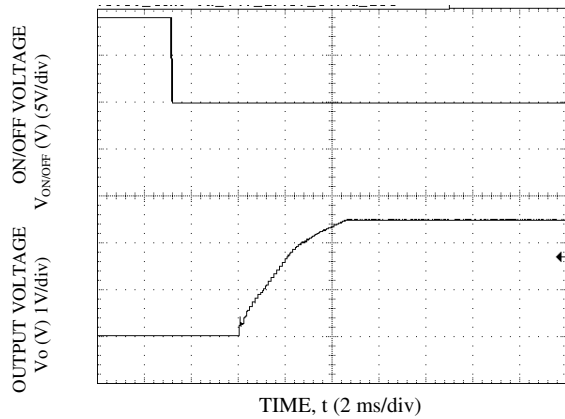

Figure 24. Start-up Using On/Off Voltage ($I_o = I_{o,max}$)
 $V_o = 2.5 V, T_a = 25^\circ C$

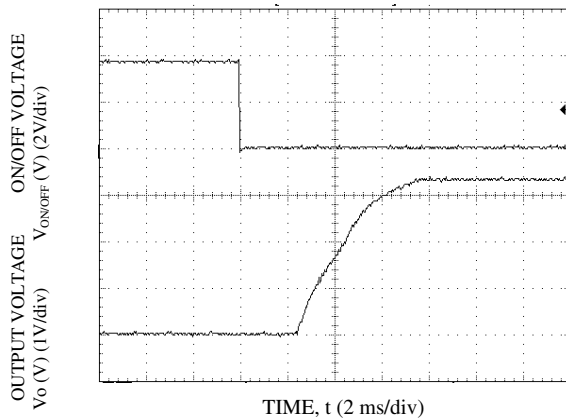

Figure 25. Start-up Using On/Off Voltage ($I_o = I_{o,max}$)
 $V_o = 3.3 V, T_a = 25^\circ C$

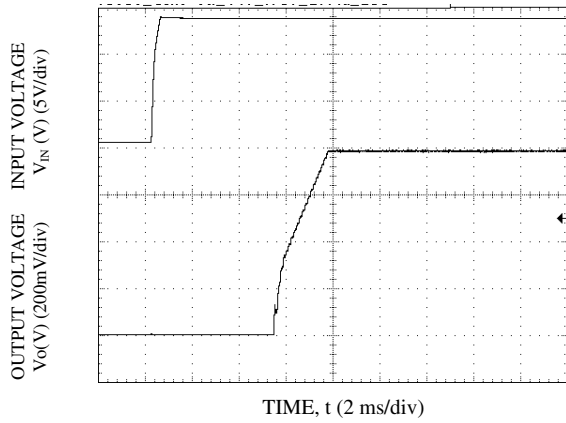

Figure 26. Start-up Using Input Voltage
 (VIN = 14 V, Io = Io,max), Vo = 0.8 V, Ta = 25°C

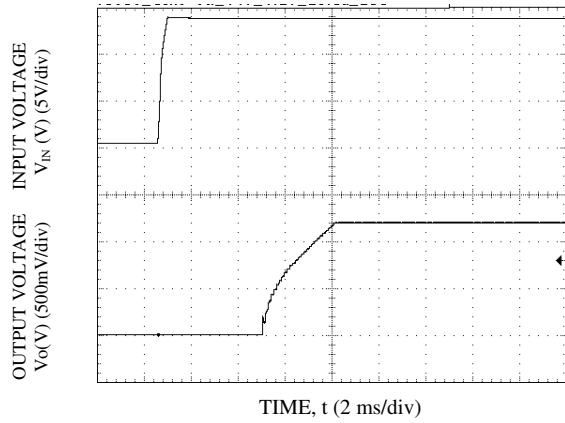

Figure 27. Start-up Using Input Voltage
 (VIN = 14 V, Io = Io,max), Vo = 1.2 V, Ta = 25°C

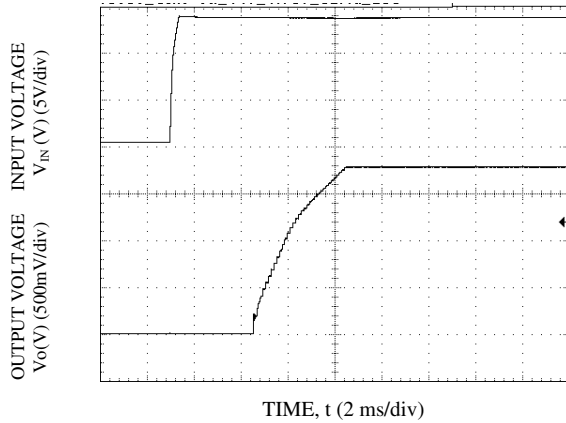

Figure 28. Start-up Using Input Voltage
 (VIN = 14 V, Io = Io,max), Vo = 1.8 V, Ta = 25°C

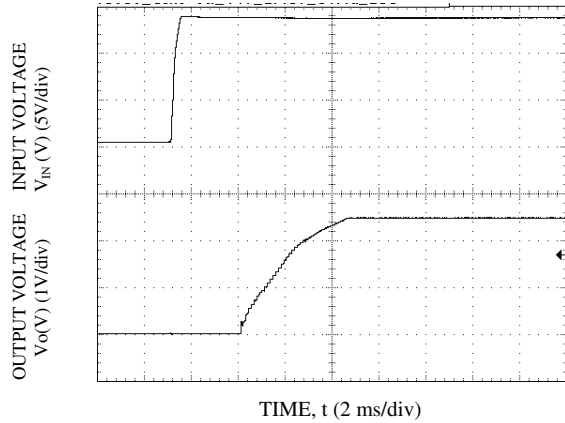

Figure 29. Start-up Using Input Voltage
 (VIN = 14 V, Io = Io,max), Vo = 2.5 V, Ta = 25°C

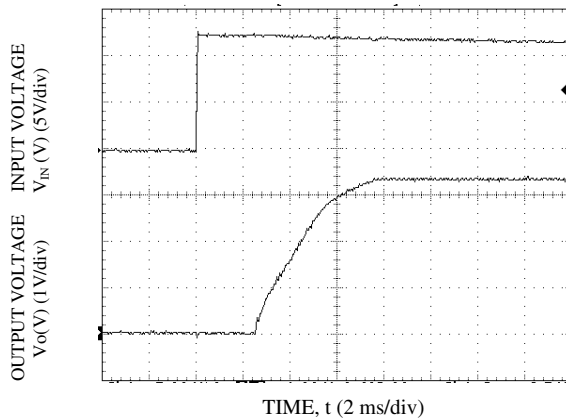
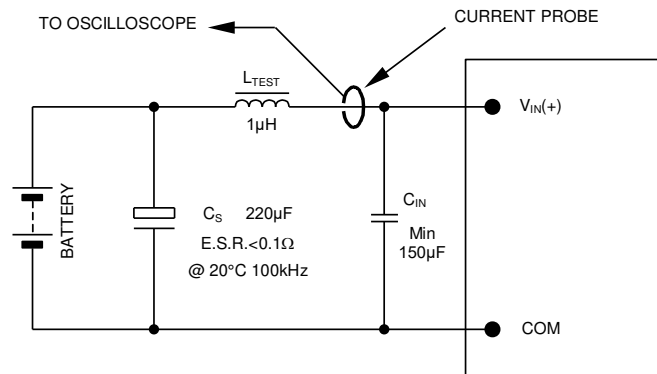

Figure 30. Start-up Using Input Voltage
 (VIN = 14V, Io = Io,max), Vo = 3.3 V, Ta = 25°C

11. TEST CONFIGURATIONS

Input Reflected Ripple Current Test Setup.



NOTE: Measure input reflected ripple current with a simulated source inductance (L_{TEST}) of $1\mu H$. Capacitor C_S offsets possible battery impedance. Measure current as shown above.

Figure 31.

Output Ripple and Noise Test Setup.

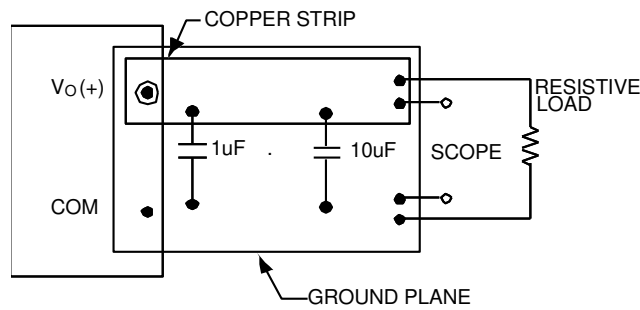

NOTE: All voltage measurements to be taken at the module terminals, as shown above. If sockets are used then Kelvin connections are required at the module terminals to avoid measurement errors due to socket contact resistance.

Figure 32.

Output Voltage and Efficiency Test Setup.

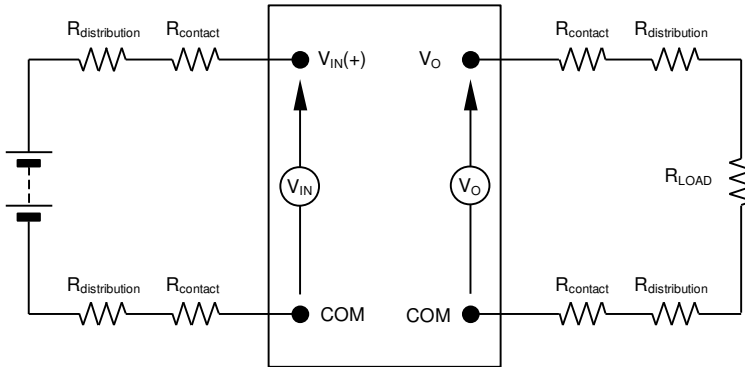

NOTE: All voltage measurements to be taken at the module terminals, as shown above. If sockets are used then Kelvin connections are required at the module terminals to avoid measurement errors due to socket contact resistance.

$$\text{Efficiency } \eta = \frac{V_o \cdot I_o}{V_{IN} \cdot I_{IN}} \times 100 \%$$

Figure 33.

12. INPUT FILTERING

The SLIN-30E1AL module should be connected to a low ac-impedance source. A highly inductive source can affect the stability of the module. An input capacitor must be placed directly adjacent to the input pin of the module, to minimize input ripple voltage and ensure module stability.

To minimize input voltage ripple, low-ESR polymer and ceramic capacitors are recommended at the input of the module. The figure below shows the input ripple voltage for various output voltages at 30A of load current with 1x22 μF, 2x22 μF or 2x47 μF ceramic capacitors and an input of 12 V.

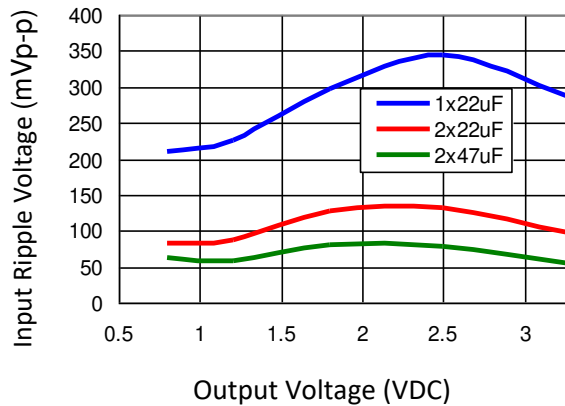

Figure 34.

13. OUTPUT FILTERING

The SLIN-30E1AL modules are designed for low output ripple voltage and will meet the maximum output ripple specification with no external capacitors. However, additional output filtering may be required by the system designer for a number of reasons. First, there may be a need to further reduce the output ripple and noise of the module. Second, the dynamic response characteristics may need to be customized to a particular load step change.

To reduce the output ripple and improve the dynamic response to a step load change, additional capacitance at the output can be used. Low ESR ceramic and polymer are recommended to improve the dynamic response of the module. For stable operation of the module, limit the capacitance to less than the maximum output capacitance as specified in the electrical specification table. Optimal performance of the module can be achieved by using the Tunable Loop feature described later in this data sheet. The figure below shows the output ripple voltage for various output voltages at 30A of load current with external 1x10 μ F, 1x47 μ F, 2x47 μ F or 4x47 μ F ceramic capacitors and an input of 12 V.

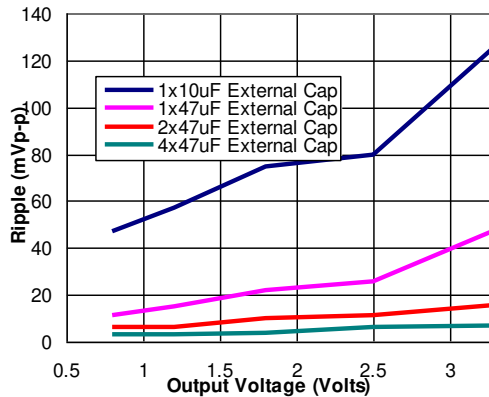

Figure 35.

14. SAFETY CONSIDERATIONS

For safety agency approval the power module must be installed in compliance with the spacing and separation requirements of the end-use safety agency standards, i.e., UL/CSA 62368-1 Licensed. The SLIN-30E1AL was tested using a 30 A, time delay fuse in the ungrounded input.

For the converter output to be considered meeting the requirements of electrical energy source class 1 (ES1), the input must meet ES1 requirements. The input to these units is to be provided with a time-delay fuse with a maximum rating of 30 A in the positive input lead.

15. REMOTE ON/OFF

PARAMETER		DESCRIPTION	MIN	TYP	MAX	UNIT
Signal Low (Unit On)	Active Low	The remote on/off pin open, Unit off.	-0.3	-	1.2	V
Signal High (Unit Off)			3.0	-	$V_{in,max}$	

The SLIN-30E1AL power modules feature an On/Off pin for remote On/Off operation. If not using the On/Off pin, connect the pin to ground (the module will be ON). The On/Off signal ($V_{ON/OFF}$) is referenced to ground. The circuit configuration for remote On/Off operation of the module using the On/Off pin is shown below.

During a Logic High on the On/Off pin (transistor Q1 is OFF), the module remains OFF. The external resistor R1 should be chosen to maintain 3.0V minimum on the On/Off pin to ensure that the module is OFF when transistor Q1 is in the OFF state. Suitable values for R1 are 4.7K for input voltage of 12V and 3K for 5Vin. During Logic-Low when Q1 is turned ON, the module is turned ON.

The On/Off pin can also be used to synchronize the output voltage start-up and shutdown of multiple modules in parallel. By connecting On/Off pins of multiple modules, the output start-up can be synchronized (please refer to characterization curves). When On/Off pins are connected, all modules will shut down if any one of the modules gets disabled due to under voltage lockout or over temperature protection.

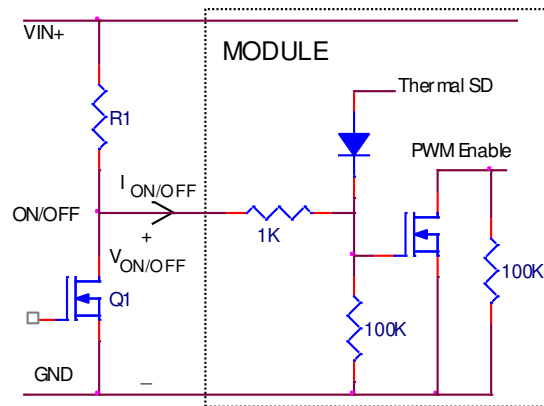

Figure 36. Remote On/Off Implementation using ON/OFF

16. OVER CURRENT PROTECTION

To provide protection in a fault (output overload) condition, the unit is equipped with internal current limiting circuitry and can endure current limiting continuously. At the point of current limit inception, the unit enters hiccup mode. The unit operates normally once the output current is brought back into its specified range.

17. OVER TEMPERATURE PROTECTION

To provide protection in a fault condition, the unit is equipped with a thermal shutdown circuit. The unit will shut down if the over temperature threshold of 125°C is exceeded at the thermal reference point Tref. The thermal shutdown is not intended as a guarantee that the unit will survive temperatures beyond its rating. Once the unit goes into thermal shutdown it will then wait to cool before attempting to restart.

18. INPUT UNDER-VOLTAGE LOCKOUT

At input voltages below the input under voltage lockout limit, the module operation is disabled. The module will begin to operate at an input voltage above the under-voltage lockout turn-on threshold.

19. OUTPUT VOLTAGE PROGRAMMING

The output voltage of the SLIN-30E1AL can be programmed to any voltage from 0.8 Vdc to 3.63 Vdc by connecting a resistor (shown as Rtrim in the figure below) between Trim and GND pins of the module. Without an external resistor between Trim and GND pins, the output of the module will be 0.8 VDC. To calculate the value of the trim resistor, Rtrim for a desired output voltage, use the following equation.

$$R_{trim} = \left[\frac{8000}{V_o - 0.8} \right] \Omega$$

Rtrim is the external resistor in Ω

Vo is the desired output voltage

By using a ±0.5% tolerance trim resistor with a TC of ±100 ppm, a set point tolerance of ±1.5% can be achieved as specified in the electrical specification. Table 1 provides Rtrim values required for some common output voltages.

VO, set (V)	RTRIM (KΩ)
0.8	Open
1.0	40
1.2	20
1.5	11.429
1.8	8
2.5	4.706
3.3	3.2

Table 1.

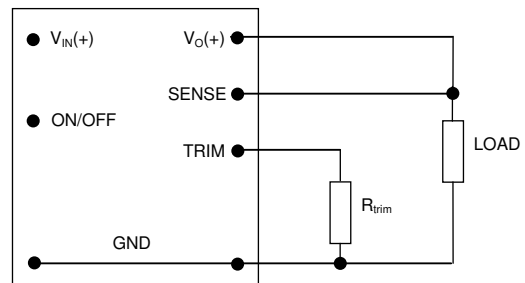

Figure 37. Circuit configuration to program output voltage using an external resistor

20. REMOTE SENSE

The SLIN-30E1AL power modules have a Remote Sense feature to minimize the effects of distribution losses by regulating the voltage at the SENSE pin. The voltage between the SENSE pin and VOUT pin must not exceed 0.5V. Note that the output voltage of the module cannot exceed the specified maximum value. This includes the voltage drop between the SENSE and Vout pins. When the Remote Sense feature is not being used, connect the SENSE pin to the VOUT pin.

21. VOLTAGE MARGINING

Output voltage margining can be implemented in the SLIN-30E1AL modules by connecting a resistor, $R_{margin-up}$, from the Trim pin to the ground pin for margining-up the output voltage and by connecting a resistor, $R_{margin-down}$, from the Trim pin to output pin for margining-down. The figure below shows the circuit configuration for output voltage margining.

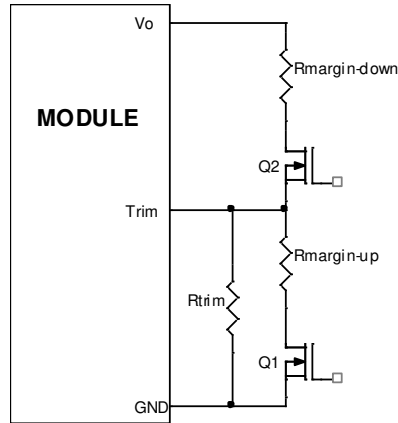

Figure 38. Circuit Configuration for margining Output voltage

22. MONOTONIC START-UP AND SHUTDOWN

The SLIN-30E1AL modules have monotonic start-up and shutdown behavior for any combination of rated input voltage, output current and operating temperature range.

23. STARTUP INTO PRE-BIASED OUTPUT

The SLIN-30E1AL modules can start into a pre-biased output as long as the pre-bias voltage is 0.5 V less than the set output voltage. Note that pre-bias operation is not supported when output voltage sequencing is used.

24. OUTPUT VOLTAGE SEQUENCING

The SLIN-30E1AL modules include a sequencing feature that enables users to implement various types of output voltage sequencing in their applications. This is accomplished via an additional sequencing pin. When not using the sequencing feature, either tie the SEQ pin to VIN or leave it unconnected.

When an analog voltage is applied to the SEQ pin, the output voltage tracks this voltage until the output reaches the set-point voltage. The final value of the SEQ voltage must be set higher than the set-point voltage of the module. The output voltage follows the voltage on the SEQ pin on a one-to-one basis. By connecting multiple modules together, multiple modules can track their output voltages to the voltage applied on the SEQ pin.

For proper voltage sequencing, first, input voltage is applied to the module. The On/Off pin of the module is left unconnected (or tied to GND for negative logic modules or tied to VIN for positive logic modules) so that the module is ON by default. After applying input voltage to the module, a minimum 10msec delay is required before applying voltage on the SEQ pin. This delay gives the module enough time to complete its internal power-up soft-start cycle. During the delay time, the SEQ pin should be held close to ground (nominally 50mV ± 20 mV). This is required to keep the internal op-amp out of saturation thus preventing output overshoot during the start of the sequencing ramp. By selecting resistor R1 according to the following equation:

$$R1 = \frac{24950}{V_{IN} - 0.05} \text{ ohms}$$

The voltage at the sequencing pin will be 50 mV when the sequencing signal is at zero.

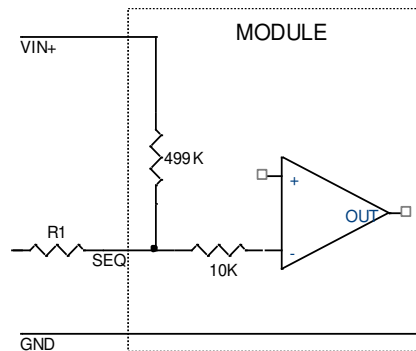

Figure 39. Circuit showing connection of the sequencing signal to the SEQ pin

After the 10 msec delay, an analog voltage is applied to the SEQ pin and the output voltage of the module will track this voltage on a one-to-one volt basis until the output reaches the set-point voltage. To initiate simultaneous shutdown of the modules, the SEQ pin voltage is lowered in a controlled manner. The output voltage of the modules tracks the voltages below their set-point voltages on a one-to-one basis. A valid input voltage must be maintained until the tracking and output voltages reach ground potential.

When using the sequencing feature to control start-up of the module, pre-bias immunity during start-up is disabled. The pre-bias immunity feature of the module relies on the module being in the diode-mode during start-up. When using the sequencing feature, modules go through an internal set-up time of 10 msec and will be in synchronous rectification mode when the voltage at the SEQ pin is applied. This will result in the module sinking current if a pre-bias voltage is present at the output of the module. When pre-bias immunity during start-up is required, the sequencing feature must be disabled. For additional guidelines on using the sequencing feature please contact the Bel Power technical representatives for additional information.

25. ACTIVE LOAD SHARING

For additional power requirements, the SLIN-30E1AL power module is also available with a parallel option. Up to five modules can be configured, in parallel, with active load sharing.

Good layout techniques should be observed when using multiple units in parallel. To implement forced load sharing, the following connections should be made:

- The share pins of all units in parallel must be connected. The path of these connections should be as direct as possible.
- All remote-sense pins should be connected to the power bus at the same point, i.e., connect all the SENSE(+) pins to the (+) side of the bus. Close proximity and directness are necessary for good noise immunity.

Some special considerations apply for design of converters in parallel operation:

- When sizing the number of modules required for parallel operation, take note of the fact that current sharing has some tolerance. In addition, under transient conditions such as a dynamic load change and during startup, all converter output currents will not be equal. To allow for such variation and avoid the likelihood of a converter shutting off due to a current overload, the total capacity of the paralleled system should be no more than 75% of the sum of the individual converters. As an example, for a system of four SLIN-30E1AL converters in parallel, the total current drawn should be less than 75% of (4 x 30A), i.e., less than 90A.
- All modules should be turned on and off together. This is so that all modules come up at the same time avoiding the problem of one converter sourcing current into the other leading to an over current trip condition. To ensure that all modules come up simultaneously, the on/off pins of all paralleled converters should be tied together and the converters enabled and disabled using the on/off pin.
- The share bus is not designed for redundant operation and the system will be non-functional upon failure of one of the units when multiple units are in parallel. In particular, if one of the converters shuts down during operation, the other converters may also shut down due to their outputs hitting current limit. In such a situation, unless a coordinated restart is ensured, the system may never properly restart since different converters will try to restart at different times causing an overload condition and subsequent shutdown. This situation can be avoided by having an external output voltage monitor circuit that detects a shutdown condition and forces all converters to shut down and restart together. When not using the sequencing feature, share pins should be left unconnected.

26. TUNABLE LOOP™

The SLIN-30E1AL modules have a new feature that optimizes transient response of the module called Tunable Loop™.

External capacitors are usually added to the output of the module for two reasons: to reduce output ripple and noise and to reduce output voltage deviations from the steady-state value in the presence of dynamic load current changes. Adding external capacitance however affects the voltage control loop of the module, typically causing the loop to slow down with sluggish response. Larger values of external capacitance could also cause the module to become unstable.

The Tunable Loop™ allows the user to externally adjust the voltage control loop to match the filter network connected to the output of the module. The Tunable Loop™ is implemented by connecting a series R-C between the SENSE and TRIM pins of the module. This R-C allows the user to externally adjust the voltage loop feedback compensation of the module.

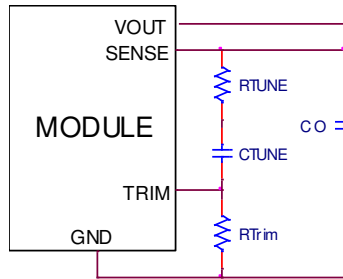

Figure 40. Circuit diagram showing connection of R_{TUNE} and C_{TUNE} to tune the control loop of the module.

Recommended values of R_{TUNE} and C_{TUNE} for different output capacitor combinations are given in Tables 2 and 3. Table 2 shows the recommended values of R_{TUNE} and C_{TUNE} for different values of ceramic output capacitors up to 1000uF that might be needed for an application to meet output ripple and noise requirements. Selecting R_{TUNE} and C_{TUNE} according to Table 2 will ensure stable operation of the module.

In applications with tight output voltage limits in the presence of dynamic current loading, additional output capacitance will be required. Table 3 lists recommended values of R_{TUNE} and C_{TUNE} in order to meet 2% output voltage deviation limits for some common output voltages in the presence of a 15 A to 30 A step change (50% of full load), with an input voltage of 12 V.

Table 2. General recommended values of R_{TUNE} and C_{TUNE} for $V_{in} = 12\text{ V}$ and various external ceramic capacitor combinations.

C_o	1x47 μF	2x47 μF	4x47 μF	10x47 μF	20x47 μF
R_{TUNE}	560 Ω	390 Ω	390 Ω	220 Ω	220 Ω
C_{TUNE}	270 pF	470 pF	820 pF	2200 pF	4700 pF

Table 2.

Table 3. Recommended values of R_{TUNE} and C_{TUNE} to obtain transient deviation of $\leq 2\%$ of V_{out} for a 15A step load with $V_{in} = 12\text{ V}$.

V_o	3.3 V	2.5 V	1.8 V	1.2 V	0.8 V
C_o	2x47 μF + 3x330 μF Polymer	3x47 μF + 3x330 μF Polymer	3x47 μF + 4x330 μF Polymer	7x330 μF Polymer	2x47 μF + 10x330 μF Polymer
R_{TUNE}	390 Ω	390 Ω	330 Ω	220 Ω	150 Ω
C_{TUNE}	2200 pF	3900 pF	6800 pF	10 nF	56 nF
ΔV	66 mV	50 mV	36 mV	24 mV	16 mV

Table 3.



Asia-Pacific +86 755 298 85888 Europe, Middle East +353 61 49 8941 North America +1 866 513 2839

27. THERMAL CONSIDERATIONS

Power modules operate in a variety of thermal environments; however, sufficient cooling should always be provided to help ensure reliable operation.

Considerations include ambient temperature, airflow, module power dissipation, and the need for increased reliability. A reduction in the operating temperature of the module will result in an increase in reliability. The thermal data presented here is based on physical measurements taken in a wind tunnel. The test set-up is shown below.

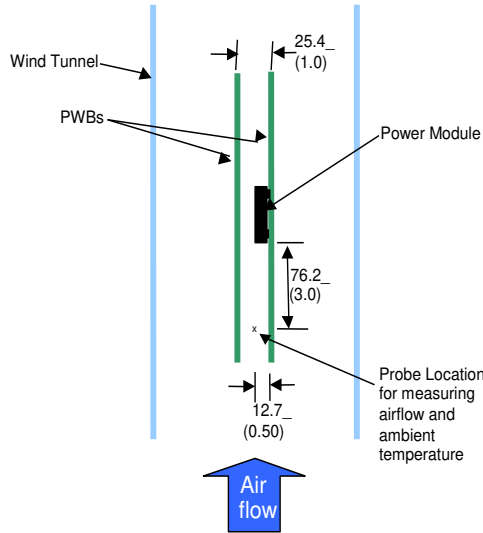

Figure 41. Thermal Test Setup

The thermal reference points, T_{ref} used in the specifications is shown below. For reliable operation the temperatures at this point should not exceed 125 °C. The output power of the module should not exceed the rated power of the module ($V_{o,set} \times I_{o,max}$).

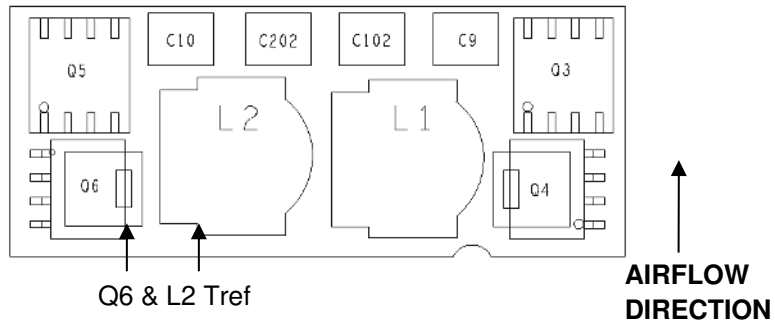

Figure 42. Preferred airflow direction and location of hot spot of the module (T_{ref})

28. EXAMPLE APPLICATION CIRCUIT

Requirements:

Vin: 12 V

Vout: 1.8 V

Iout: 22.5 A max., worst case load transient is from 15 A to 22.5 A

ΔV_{out} : 1.5% of Vout (27 mV) for worst case load transient

Vin, ripple 1.5% of Vin (180 mV, p-p)

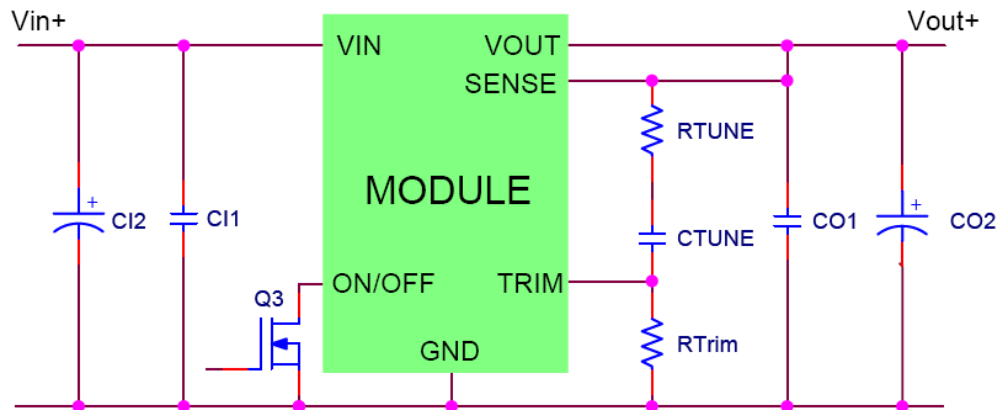

Figure 43.

C11 2 x 22 μ F/16 V ceramic capacitor (e.g. TDK C Series)

C12 100 μ F/16 V Bulk Electrolytic

CO1 3 x 47 μ F/6.3 V ceramic capacitor (e.g. TDK C Series, Murata GRM32ER60J476ME20)

CO2 330 μ F /4 V Polymer/Poscap, Low EST (e.g. Sanyo Poscap 4TPE470MCL)

CTune 15 nF ceramic capacitor (can be 1206, 0805 or 0603 size)

RTune 430 Ω SMT resistor (can be 1206, 0805 or 0603 size)

RTrim 8 k Ω SMT resistor (can be 1206, 0805 or 0603 size, recommended tolerance of 0.1%)

29. MECHANICAL DIMENSIONS

OUTLINE

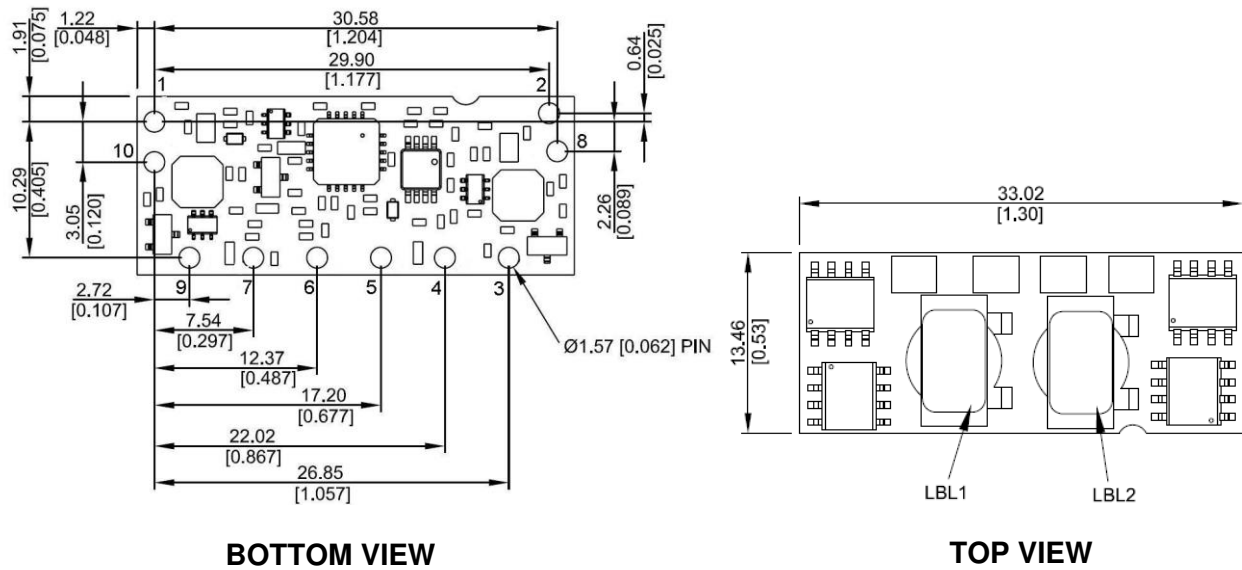

BOTTOM VIEW

TOP VIEW

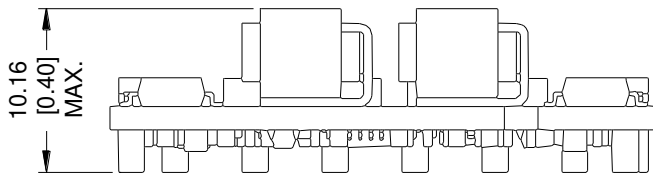

SIDE VIEW

Co-planarity (max): 0.102[0.004]

Figure 44. Outline

Notes:

Dimensions are in millimeter [inch].

Tolerances: $x.x \pm 0.5$ mm [0.02 inch] [unless otherwise indicated]

$x.xx \pm 0.25$ mm [0.010 inch]

These parts are not however compatible with the higher temperatures associated with lead free solder processes and must be soldered using a reflow profile with a peak temperature of no more than 245 °C.

PIN DEFINITION

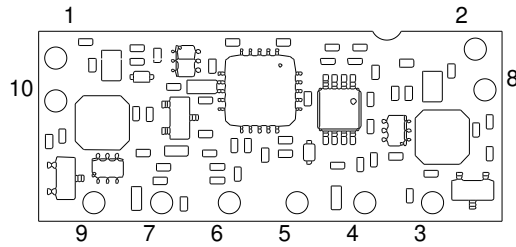

BOTTOM VIEW

Figure 45. Pins

PIN	FUNCTION	PIN	FUNCTION
1	ON/OFF	6	TRIM
2	VIN	7	SENSE
3	SEQ	8	GND
4	GND	9	SHARE
5	VOUT	10	GND

RECOMMENDED PAD LAYOUT

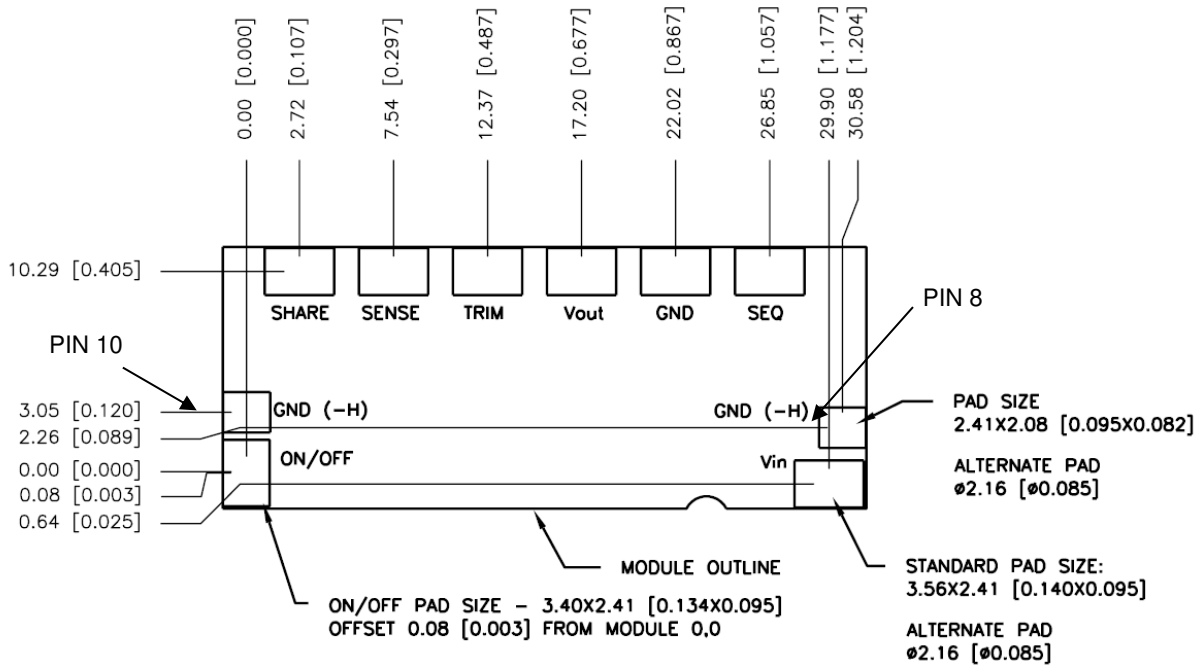
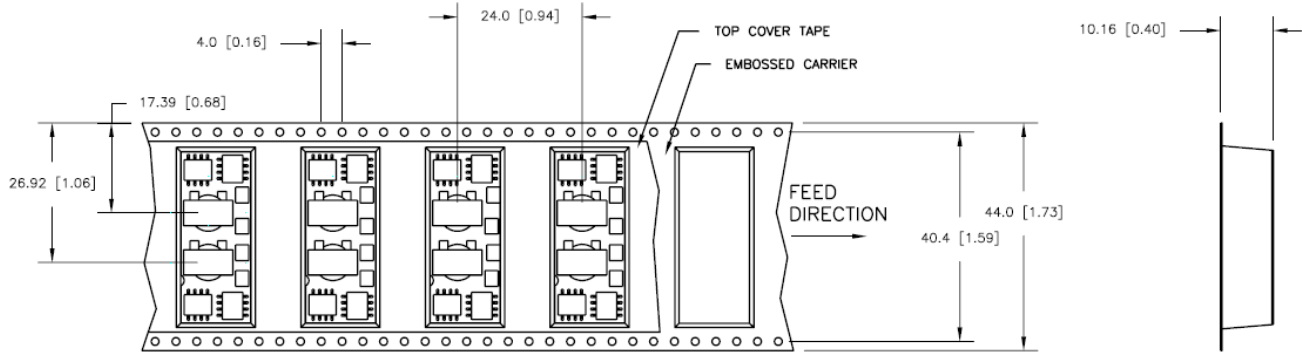

Figure 46. Recommended pad layout

30. PACKAGING DETAILS

The SLIN-30E1AL modules are supplied in tape & reel as standard.
All Dimensions are in millimeter [inch].



NOTE: CONFORMS TO EIA-481 STANDARD

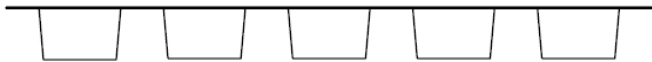

Figure 47.

Reel Dimensions:

Outside Dimensions: 330.2 mm [13.00 inch]

Inside Dimensions: 177.8 mm [7.00 inch]

Tape Width: 44.00 mm [1.73 inch]

31. SURFACE MOUNT INFORMATION

PICK AND PLACE

The SLIN-30E1AL modules use an open frame construction and are designed for a fully automated assembly process. The modules are fitted with a label designed to provide a large surface area for pick and place operations. The label meets all the requirements for surface mount processing, as well as safety standards, and is able to withstand reflow temperatures of up to 300°C. The label also carries product information such as part number and serial number.

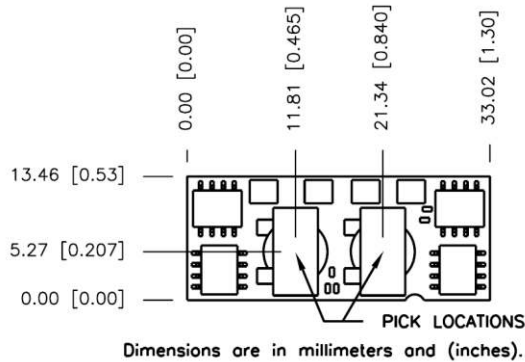

Figure 48. Pick and Place Location

NOZZLE RECOMMENDATIONS

The module weight has been kept to a minimum by using open frame construction. Even so, these modules have a relatively large mass when compared to conventional SMT components. Variables such as nozzle size, tip style, vacuum pressure and pick & placement speed should be considered to optimize this process. The minimum recommended inside nozzle diameter for reliable operation is 3 mm. The maximum nozzle outer diameter, which will safely fit within the allowable component spacing, is 5 mm max.

TIN LEAD SOLDERING

The SLIN-30E1AL power modules are lead free modules and can be soldered either in a lead-free solder process or in a conventional Tin/Lead (Sn/Pb) process. It is recommended that the customer review data sheets in order to customize the solder reflow profile for each application board assembly. The following instructions must be observed when soldering these units. Failure to observe these instructions may result in the failure of or cause damage to the modules and can adversely affect long-term reliability.

In a conventional Tin/Lead (Sn/Pb) solder process peak reflow temperatures are limited to less than 235°C. Typically, the eutectic solder melts at 183°C, wets the land, and subsequently wicks the device connection. Sufficient time must be allowed to fuse the plating on the connection to ensure a reliable solder joint. There are several types of SMT reflow technologies currently used in the industry. These surface mount power modules can be reliably soldered using natural forced convection, IR (radiant infrared), or a combination of convection/IR. For reliable soldering the solder reflow profile should be established by accurately measuring the modules CP connector temperatures.

LEAD FREE SOLDERING

The SLIN-30E1AL modules are lead-free (Pb-free) and RoHS compliant and are both forward and backward compatible in a Pb-free and a SnPb soldering process. Failure to observe the instructions may result in the failure of or cause damage to the modules and can adversely affect long-term reliability.

PB-FREE REFLOW PROFILE

Power Systems will comply with J-STD-020 Rev. C (Moisture/Reflow Sensitivity Classification for Nonhermetic Solid State Surface Mount Devices) for both Pb-free solder profiles and MSL classification procedures. This standard provides a recommended forced-air-convection reflow profile based on the volume and thickness of the package. The suggested Pb-free solder paste is Sn/Ag/Cu (SAC). The recommended linear reflow profile using Sn/Ag/Cu solder is shown below.

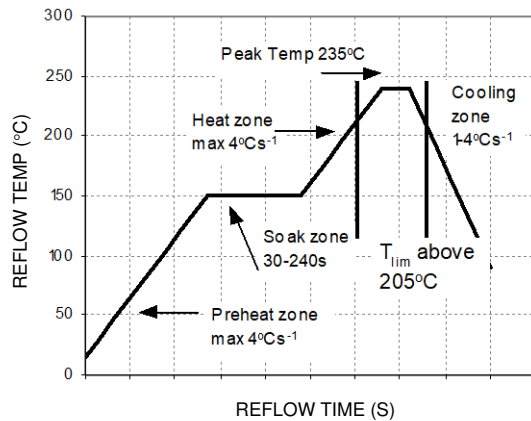

Figure 49. Reflow Profile for Tin/Lead (Sn/Pb) process

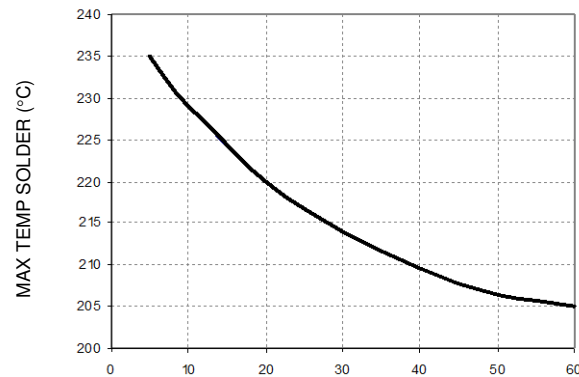

Figure 50. Time Limit Curve Above 205°C Reflow for Tin Lead (Sn/Pb) process

MSL RATING

The SLIN-30E1AL modules have a MSL rating of 2A.

STORAGE AND HANDLING

The recommended storage environment and handling procedures for moisture-sensitive surface mount packages is detailed in J-STD-033 Rev. A (Handling, Packing, Shipping and Use of Moisture/Reflow Sensitive Surface Mount Devices). Moisture barrier bags (MBB) with desiccant are required for MSL ratings of 2 or greater. These sealed packages should not be broken until time of use. Once the original package is broken, the floor life of the product at conditions of $\leq 30^{\circ}\text{C}$ and 60% relative humidity varies according to the MSL rating (see J-STD-033A). The shelf life for dry packed SMT packages will be a minimum of 12 months from the bag seal date, when stored at the following conditions: $< 40^{\circ}\text{C}$, $< 90\%$ relative humidity.

POST SOLDER CLEANING AND DRYING CONSIDERATIONS

Post solder cleaning is usually the final circuit board assembly process prior to electrical board testing. The result of inadequate cleaning and drying can affect both the reliability of a power module and the testability of the finished circuit board assembly.

32. REVISION HISTORY

DATE	REVISION	CHANGES DETAIL	APPROVAL
2010-01-11	A	First release	T. Bubriski
2010-06-08	B	Update the Vout range from 2.75 VDC to 3.63 VDC.	T. Bubriski
2010-07-26	C	Corrected required fuse type on page 2.	T. Bubriski
2010-12-02	D	Updated the Active Load Sharing Section on page 17.	T. Bubriski
2015-07-29	E	Update UL in features, update part Selection, part number explanation, absolute maximum ratings, MSL rating, add label and the reflow solder temperature in mechanical outline.	XF.Jiang
2021-08-11	AF	Add object ID and module photo. Update safety certificate and mechanical drawing height. Update to new format.	XF.Jiang

For more information on these products consult: tech.support@psbel.com

NUCLEAR AND MEDICAL APPLICATIONS - Products are not designed or intended for use as critical components in life support systems, equipment used in hazardous environments, or nuclear control systems.

TECHNICAL REVISIONS - The appearance of products, including safety agency certifications pictured on labels, may change depending on the date manufactured. Specifications are subject to change without notice.



Asia-Pacific
+86 755 298 85888

Europe, Middle East
+353 61 49 8941

North America
+1 866 513 2839