

THIS DRAWING IS UNPUBLISHED. RELEASED FOR PUBLICATION
 © COPYRIGHT - By - ALL RIGHTS RESERVED.

REVISIONS					
P	LTR	DESCRIPTION	DATE	DM	APD
AP3		REVISED PER EOR-17-013047	12SEP17	J.Z	D.Z

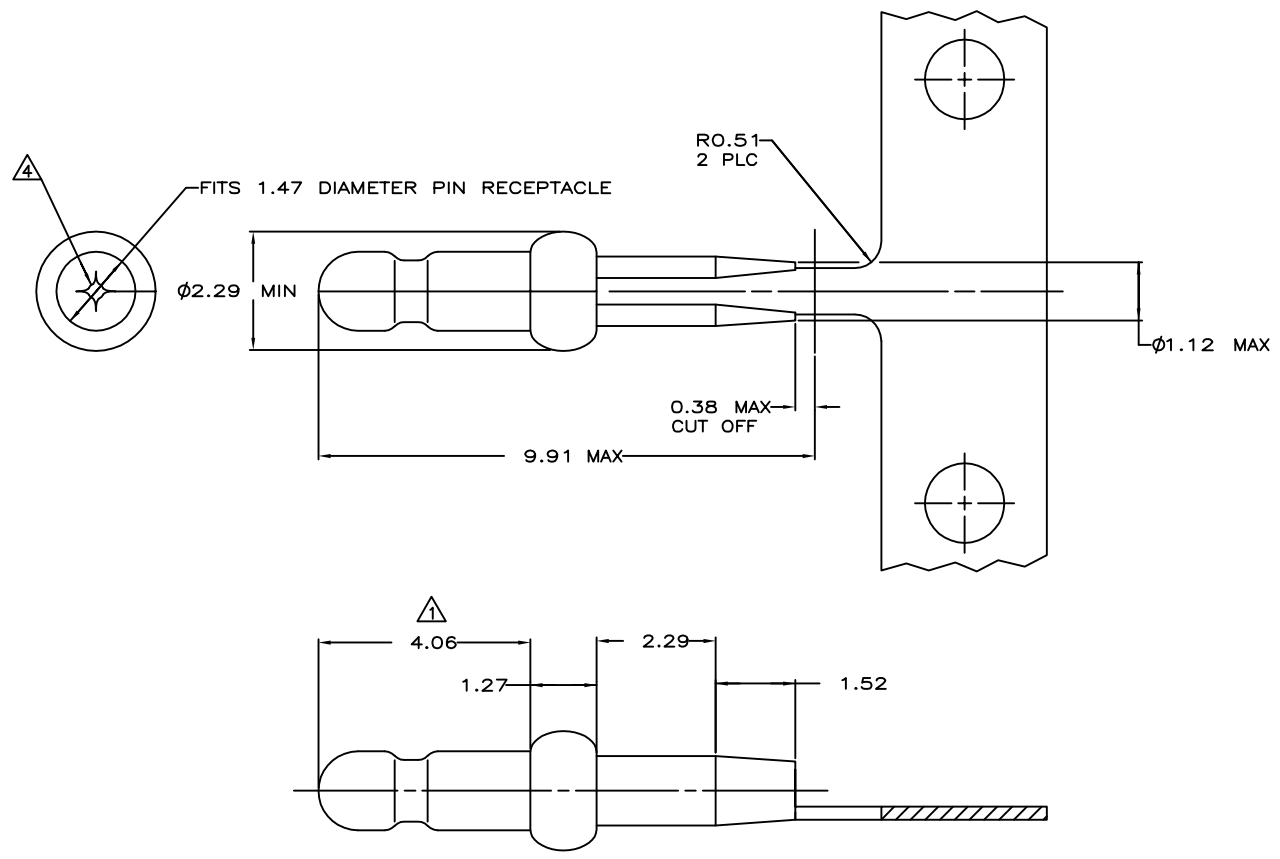

- △ 0.00076 MIN GOLD PLATING IN THIS AREA WITH 0.00381 MIN MATTE TIN LEAD ON THE REMAINDER, BOTH OVER 0.00127 MIN NICKEL UNDERPLATE.
- 2. FITS 1.17 - 1.27 DIAMETER HOLE IN A 1.57 OR 2.36 PRINTED CIRCUIT BOARD.
- 3. PARTS TO COMPLY WITH AMP SOLDERABILITY SPECIFICATION 109-11-3.
- △ 0.05 - 0.25 DIAMETER OPENING REQUIRED IN TIP OF PIN.
- 5. APPLICATOR FEED: 8.00 - 8.26
- △ 0.00076 MIN GOLD PLATING IN THIS AREA WITH 0.00381 MIN MATTE TIN ON THE REMAINDER, BOTH OVER 0.00127 MIN NICKEL UNDERPLATE.

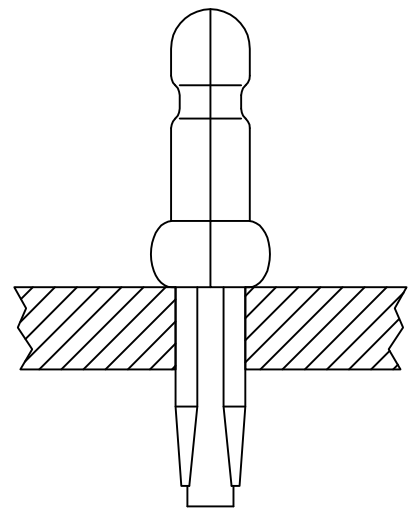
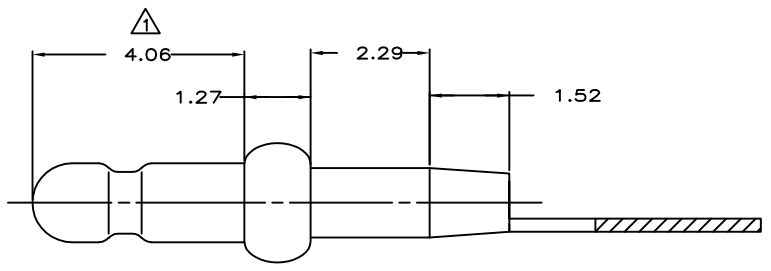

OBSOLETE	△	3-60802-1
	PRE TIN	60802-2
	△	60802-1
	FINISH	PART NUMBER

0.13	.005	1.17	.046	2.29	.090	9.91	.390
0.05	.002	1.12	.044	1.57	.062	8.26	.325
0.00381	0.000150	0.51	.020	1.52	.060	8.00	.315
0.00127	0.000050	0.38	.015	1.47	.058	4.06	.160
0.00076	0.000030	0.25	.010	1.27	.050	2.36	.093
MM	IN	MM	IN	MM	IN	MM	IN

CONVERSION TABLE



THIS DRAWING IS A CONTROLLED DOCUMENT.

DIMENSIONS:	mm	TOLERANCES UNLESS OTHERWISE SPECIFIED:	0 PLC ± -	1 PLC ± -	2 PLC ± 0.13	3 PLC ± -	4 PLC ± -	ANGLES ± -	
MATERIAL	0.25 PH BRZ	FINISH	SEE TABLE	DWG: T. BECK 7-28-97 CHK: R. SWING 7-28-97 APNG: A. BEDDICK 9-10-97 PRODUCT SPEC: 108-1025 APPLICATION SPEC: 114-1008 WEIGHT: 0.000000 CUSTOMER DRAWING					
TE Connectivity PIN, .058 DIAMETER, PHOSPHER BRONZE, PRESS FIT, P.C. CONTACT			SIZE: A2	CAGE CODE: 00779	DRAWING NO: 60802	RESTRICTED TO: -	SCALE: 15:1	SHEET: 1 of 1	REV: AP3