

PRODUCT NUMBER
SEE TABLE

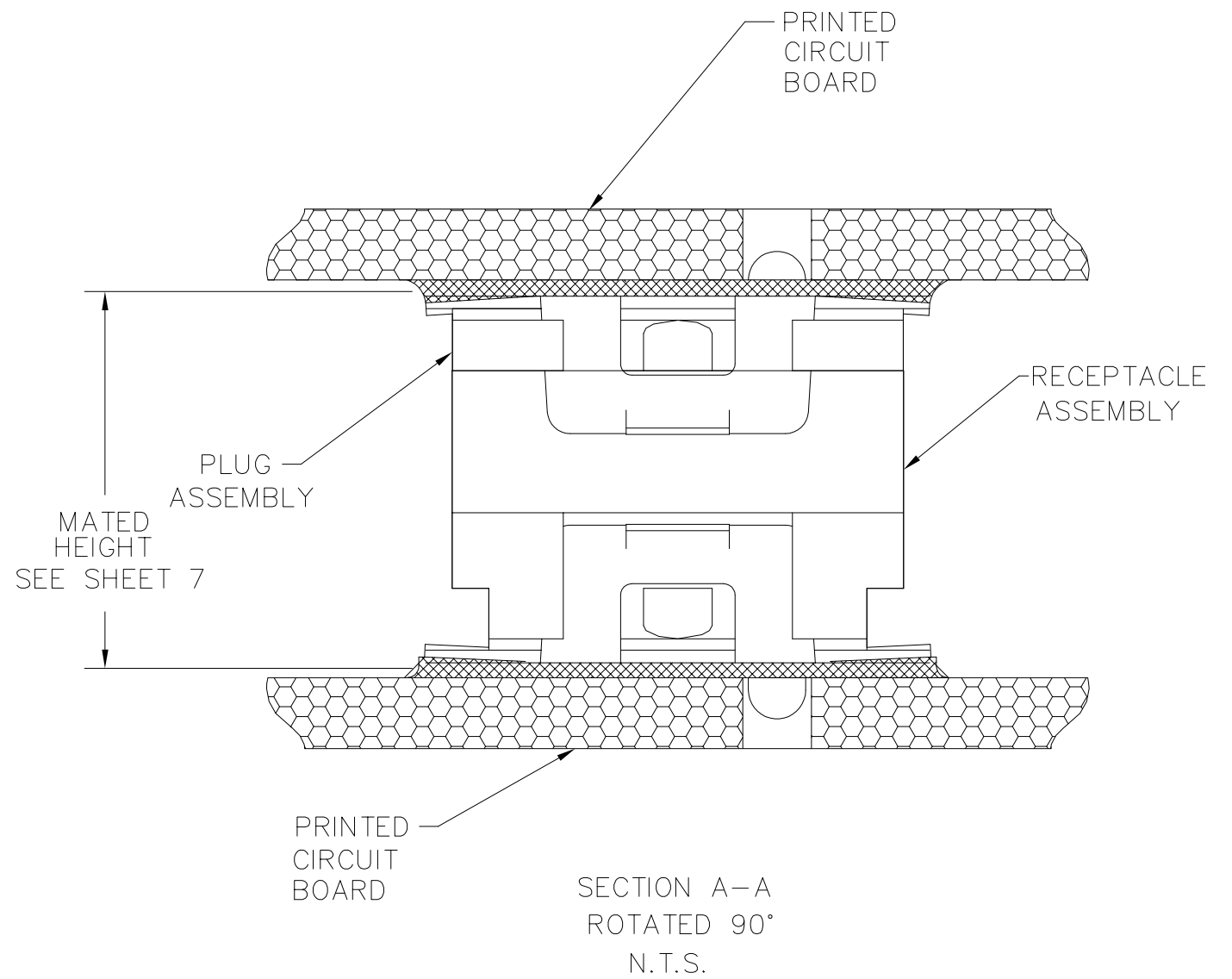
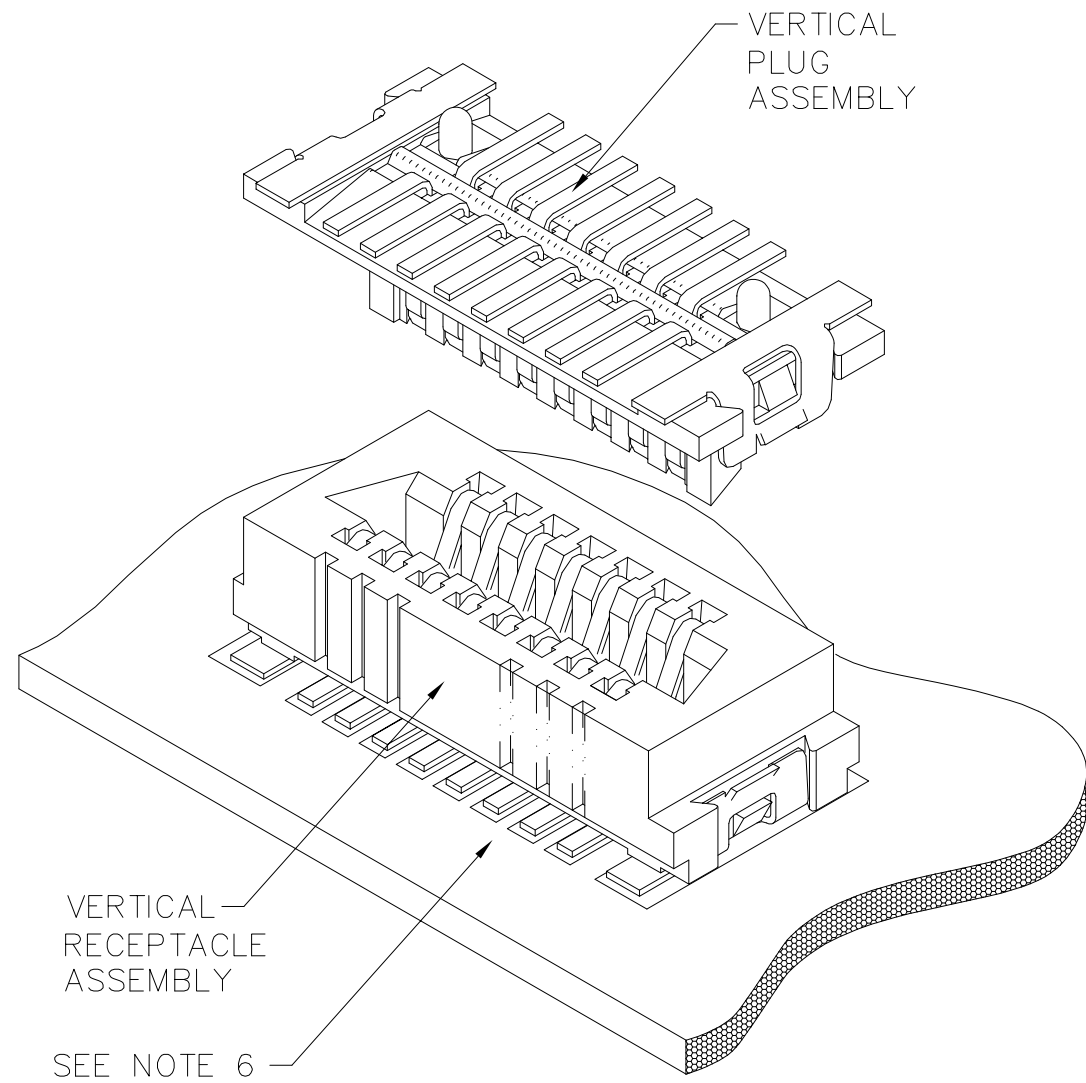

Amphenol
FCi

© 2016 AFCI

mat'l. code		surface		tolerance		projection		product family	
Bob		ISO 1302 ✓		ISO 406 ISO 1101		1101		CONAN HPL548	
ltr		ecn no		dr		date		title	
A		N11-0214		Bob		2020-03-22		ASSEMBLY CONAN PLUG	
				angles		linear		mm	
				0°±2°		.0±.3 .00±.13 .000±.05		scale 1:1	
				dr		Bob Gu 2020-03-22		dwg no	
				enr		Bob Gu 2020-03-22		sheet 1 of 5	
				chr		LQ Lei 2020-03-22		10162582	
				appd		Tim Yao 2020-03-22		A3	
sheet index		revision		A				type	
sheet		1~5						Product Customer Drawing	

PRODUCT NUMBER
SEE TABLE

CONAN[®] ASSEMBLY PART NUMBER

10162582 - T C W 4 Y ZZ LF

LEAD FREE
SEE NOTE 8

TYPE	T
PLUG W/O PEGS	0
PLUG WITH PEGS	1

PICK AND PLACE CAP OR TAPE	C
W/O CAP	0
WITH CAP	1

PACKAGING	W
TUBE	2
PRESSURE SEALED TAPE & REEL	3

Y	PLUG HEIGHT	RECEPTACLE HEIGHT	MATED HEIGHT	+ .010 - .008 [+.25] [-.20]
1	.034 [.86]	.129 [3.28]	.163 [4.15]	
2	.048 [1.23]	SEE Y=1 FOR ALL RECEPTACLES	.177 [4.50]	
3	.068 [1.73]		.197 [5.00]	
4	.107 [2.72]		.236 [6.00]	
5	.1465 [3.721]		.276 [7.00]	

ZZ	NUMBER OF POSITIONS
09	9
11	11
15	15
21	21
25	25
31	31
41	41
51	51
69	69

W	PLATING
4	GOLD FLASH

NOTES:

- MATERIALS:
HOUSING - LCP, UL-94V-0. COLOR: NATURAL.
TERMINALS - COPPER ALLOY,
PLATED WITH GOLD IN CONTACT AREA
AND 100u"/2.54u Sn ON SOLDER LEGS WITH
AN OVERALL 50u"/1.27u Ni UNDERPLATE.
RETENTION DEVICE - BRASS,
PLATED WITH 100u"/2.54u Sn OVER NICKEL.
- REFERENCE GS-12-0977 FOR PRODUCT PERFORMANCE
AND ENVIRONMENTAL RESISTANCE DATA.
- SEE TA-774 FOR FURTHER DESCRIPTION OF
HOW THIS DIMENSION IS APPLIED.
- PICK AND PLACE CAP OR TAPE IS ONLY AVAILABLE WITH
OPTION 3 PACKAGING. (PSA ADHESIVE SEALED).
ALSO, PSA PACKAGING REQUIRES A PICK AND
PLACE CAP.
- RECOMMENDED SOLDER PASTE THICKNESS IS
.006 TO .008 INCHES THICK.
- THE TOE HEIGHT OF THE SOLDER TAIL SHALL BE
MEASURED FROM THE LOWEST POINT OF THE .004
CO-PLANARITY GRAVITY PLANE. THIS MEASUREMENT
IS NOT TO EXCEED A WINDOW OF .000 TO .007 INCHES.
- THREE SLOTS MAY BE LOCATED AT EITHER END OF
HOUSING.
- 5.50mm MATED HEIGHT IS ONLY AVAILABLE
IN 9, 15 AND 31 POS.
- 7.50mm MATED HEIGHT IS ONLY AVAILABLE
IN 9 POS.

EXAMPLE: 10162582-3131125LF
IS A CONAN RECEPTACLE ASSEMBLY,
HAVING PEGS AND WITH A PICK AND PLACE CAP.
IT IS .13 [3.2] HIGH AND 25 POSITIONS AND IS
PACKAGED IN PRESSURE SEALED TAPE, REEL AND LEAD FREE.

- APPLIES TO 91921-3XYZZ AND
91931- 3XYZZ OPTIONS ONLY.
- THE HOUSING WILL WITHSTAND EXPOSURE TO 260°C PEAK TEMPERATURE
FOR 30 SECONDS IN A CONVECTION INFRA RED OR VAPOR PHASE
REFLOW OVEN. SEE APPLICATION/PROCEDURES IF THEY ARE AVAILABLE
- PRODUCT WITH "LF" AT THE END MEETS EUROPEAN UNION DIRECTIVES AND OTHER
COUNTRY REGULATION AS DESCRIBED IN GS-22-008.

mat'l. code Bob		surface ISO 1302 ✓	tolerance ISO 406 ISO 1101	projection 1101	product family CONAN HPL548
ltr	ecn no	dr	date	tolerances unless otherwise specified	title
A				angles linear .0±.3 .00±.13 .000±.05	ASSEMBLY CONAN PLUG
				0°±2°	mm
		dr	Bob Gu 2020-03-22	scale 1:1	dwg no sheet 2 of 5 size
		enr	Bob Gu 2020-03-22		10162582 A3
		chr	LQ Lei 2020-03-22		
		appd	Tim Yao 2020-03-22		type Product Customer Drawing
sheet index	revision sheet	A	1~5		

Amphenol FCI

© 2016 AFCl

PRODUCT NUMBER
SEE TABLE

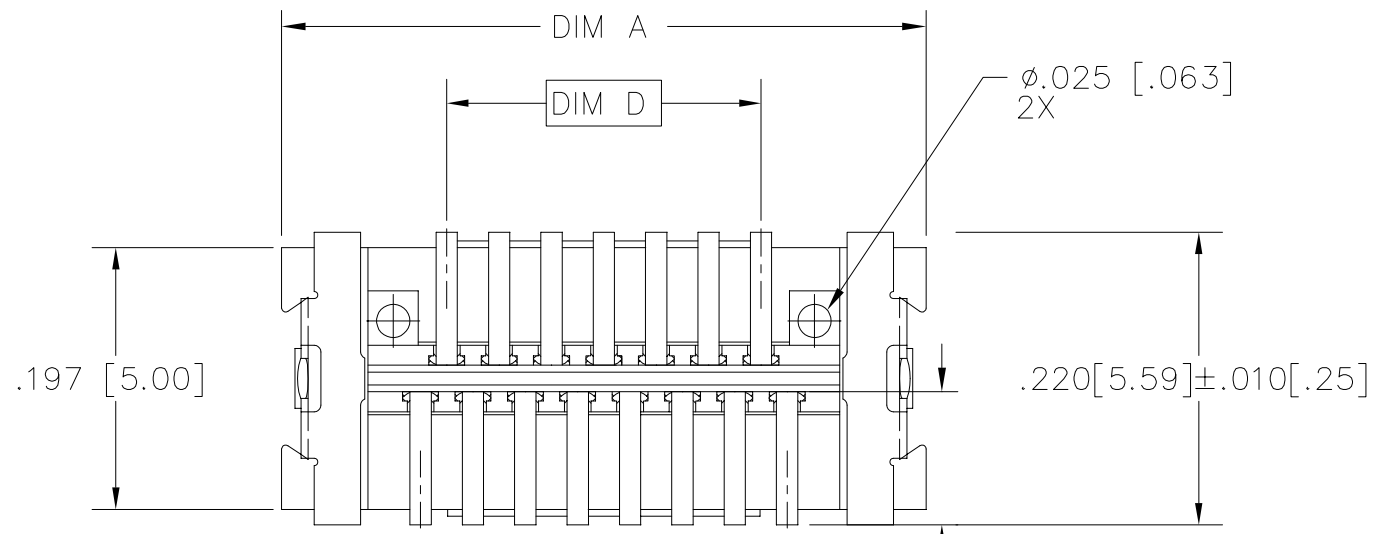

PLUG

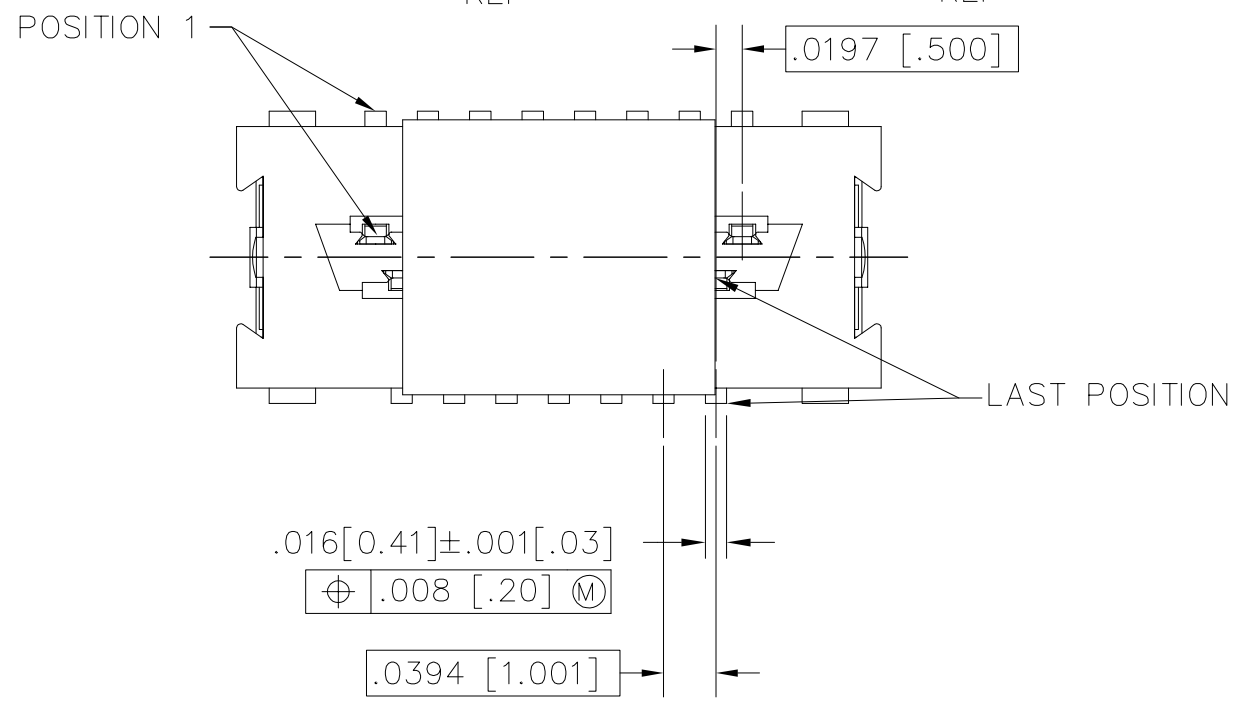
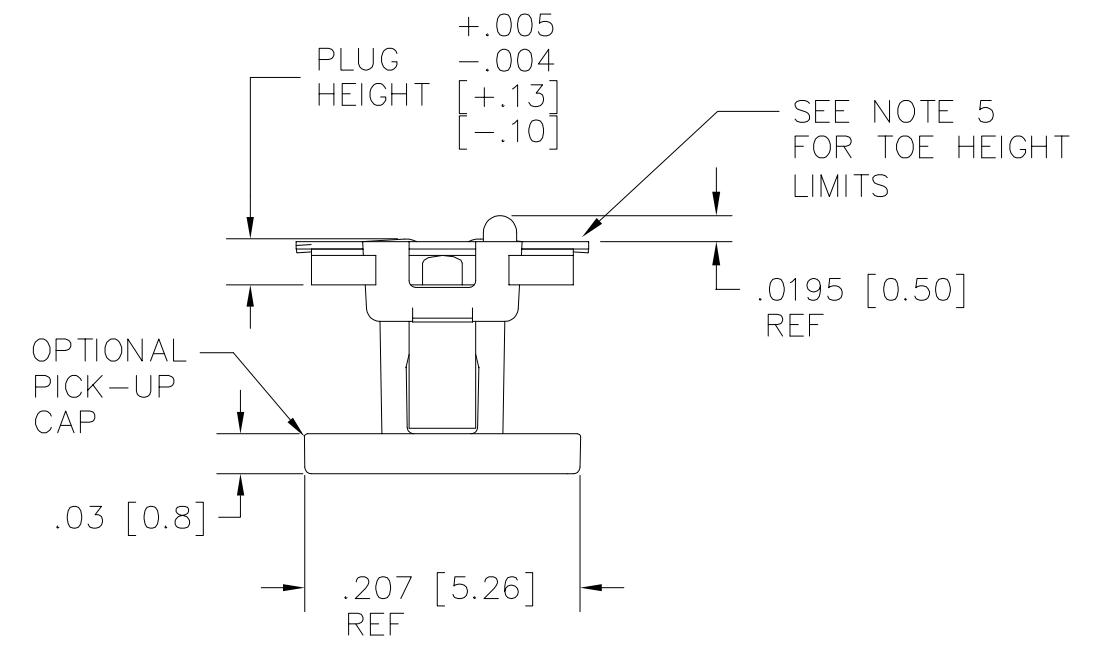
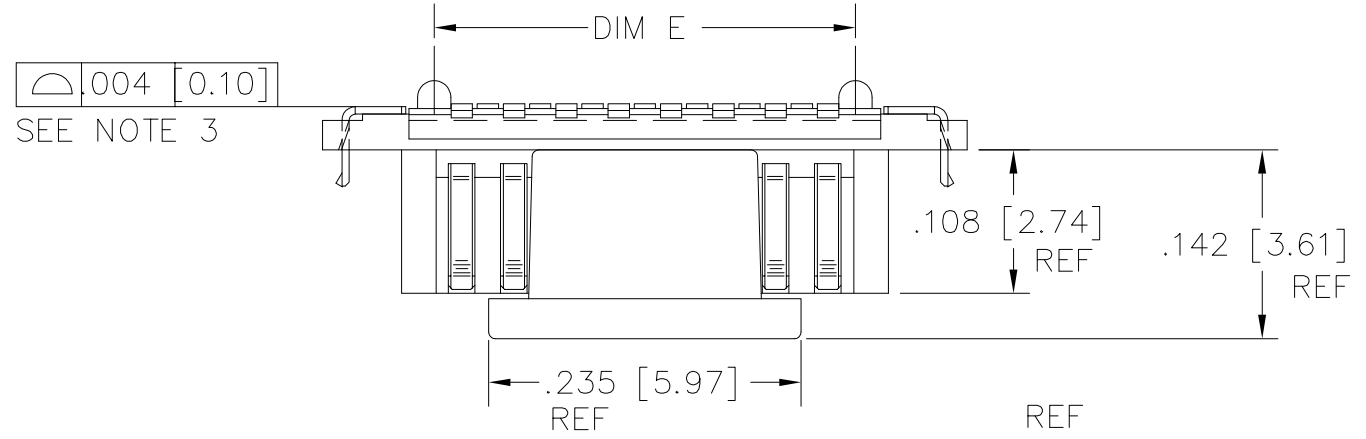

mat'l. code Bob		surface ISO 1302 ✓		tolerance ISO 406 ISO 1101		projection 1101		product family CONAN HPL548	
ltr A		ecn no dr		date		tolerances unless otherwise specified		title ASSEMBLY CONAN CONNECTOR	
						angles linear		dwg no 10162582	
						0°±2°		sheet 3 of 5	
						.0±.3		size A3	
						.00±.13		type Product Customer Drawing	
						.000±.05			
sheet index		revision sheet A		1~5		scale 1:1			
						Amphenol FCi			
						dr Bob Gu 2020-03-22			
						enr Bob Gu 2020-03-22			
						chr LQ Lei 2020-03-22			
						appd Tim Yao 2020-03-22			

PRODUCT NUMBER
SEE TABLE

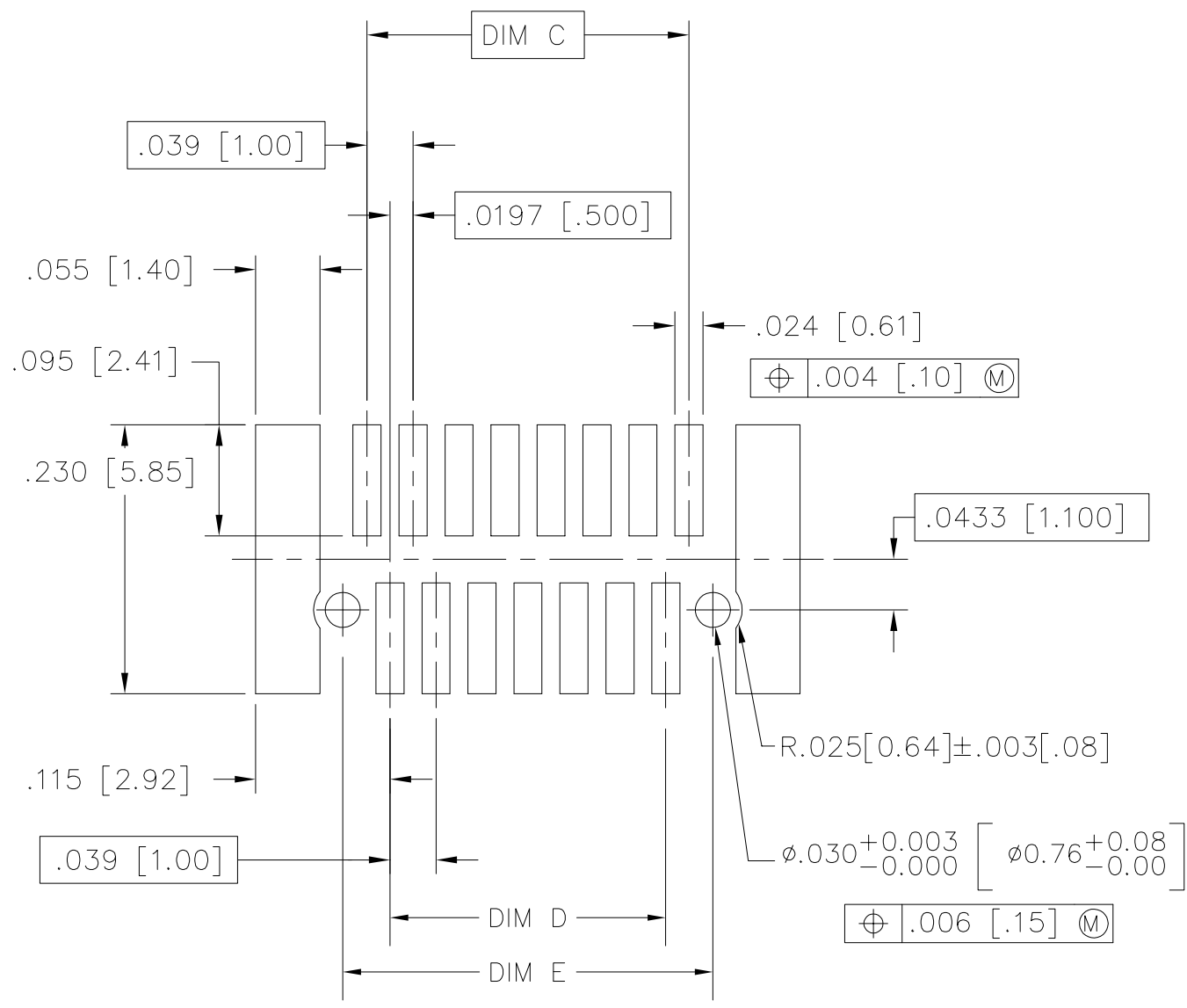

RECOMMENDED
PAD LAYOUT
FOR PLUG

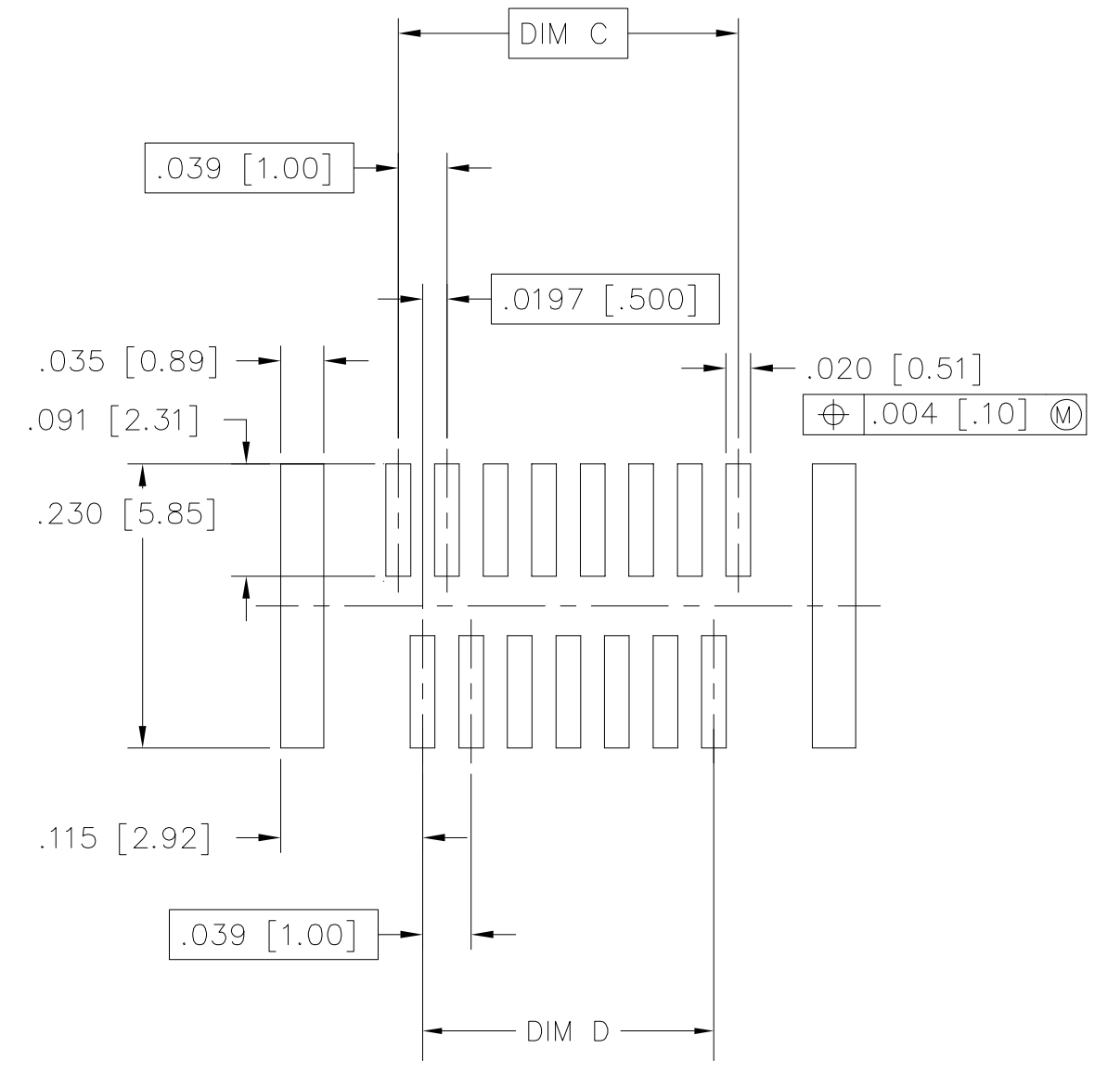

RECOMMENDED
STENCIL LAYOUT
FOR PLUG

mat'l. code		surface		tolerance		projection		product family	
Bob		ISO 1302 ✓		ISO 406 ISO 1101		1101		CONAN HPL548	
ltr		ecn no		dr		date		title	
A								ASSEMBLY CONAN CONNECTOR	
				angles		linear		mm	
				0°±2°				scale 1:1	
				dr		Bob Gu 2020-03-22		dwg no	
				enr		Bob Gu 2020-03-22		sheet 4 of 5	
				chr		LQ Lei 2020-03-22		size	
				appd		Tim Yao 2020-03-22		A3	
sheet index		revision		A				type	
sheet		1~5						Product Customer Drawing	



© 2016 AFCI

PRODUCT NUMBER	POS	DIM "A"	DIM "C"	DIM "D"	DIM "E"
10162582-TCWXY09LF	9	.366 [9.30]	.157 [4.00]	.118 [3.00]	.1990 [5.055]
-TCWXY11LF	11	.406 [10.30]	.197 [5.00]	.157 [4.00]	.2380 [6.045]
-TCWXY15LF	15	.484 [12.30]	.276 [7.00]	.236 [6.00]	.3170 [8.052]
-TCWXY21LF	21	.602 [15.30]	.394 [10.00]	.354 [9.00]	.4350 [11.049]
-TCWXY25LF	25	.681 [17.30]	.472 [12.00]	.433 [11.00]	.5140 [13.056]
-TCWXY31LF	31	.800 [20.30]	.591 [15.00]	.551 [14.00]	.6320 [16.053]
-TCWXY41LF	41	.996 [25.30]	.787 [20.00]	.748 [19.00]	.8290 [21.057]
-TCWXY51LF	51	1.193 [30.30]	.984 [25.00]	.945 [24.00]	1.0260 [26.060]
-TCWXY69LF	69	1.547 [39.30]	1.339 [34.00]	1.299 [33.00]	1.3800 [35.052]

NOTES:

- MATERIALS:
HOUSING - LCP, UL-94V-0. COLOR: NATURAL.
TERMINALS - COPPER ALLOY, PLATED WITH GOLD OR GXT IN CONTACT AREA AND 100u"/2.54u Sn ON SOLDER LEGS WITH AN OVERALL 50u"/1.27u Ni UNDERPLATE.
RETENTION DEVICE - BRASS, PLATED WITH 100u"/2.54u Sn OVER NICKEL.
- REFERENCE GS-12-0977 FOR PRODUCT PERFORMANCE AND ENVIRONMENTAL RESISTANCE DATA.
- SEE TA-774 FOR FURTHER DESCRIPTION OF HOW THIS DIMENSION IS APPLIED.
- RECOMMENDED SOLDER PASTE THICKNESS IS .006 TO .008 INCHES THICK.
- THE TOE HEIGHT OF THE SOLDER TAIL SHALL BE MEASURED FROM THE LOWEST POINT OF THE .004 CO-PLANARITY GRAVITY PLANE. THIS MEASUREMENT IS NOT TO EXCEED A WINDOW OF .000 TO .007 INCHES.
- THREE SLOTS MAY BE LOCATED AT EITHER END OF HOUSING.
- THE HOUSING WILL WITHSTAND EXPOSURE TO 260°C PEAK TEMPERATURE FOR 30 SECONDS IN A CONVECTION INFRA RED OR VAPOR PHASE REFLOW OVEN. SEE APPLICATION/PROCEDURES IF THEY ARE AVAILABLE
- PRODUCT WITH "LF" AT THE END MEETS EUROPEAN UNION DIRECTIVES AND OTHER COUNTRY REGULATION AS DESCRIBED IN GS-22-008.

Amphenol
FCI

© 2016 AFCI

mat'l. code		surface		tolerance		projection		product family	
Bob		ISO 1302 ✓		ISO 406 ISO 1101		1101		CONAN HPL548	
ltr		ecn no		dr		date		title	
A								ASSEMBLY CONAN CONNECTOR	
				tolerances unless otherwise specified		mm			
				angles		linear			
				0°±2°		.0±.3			
						.00±.13			
						.000±.05		scale 1:1	
				dr		Bob Gu		2020-03-22	
				enr		Bob Gu		2020-03-22	
				chr		LQ Lei		2020-03-22	
				appd		Tim Yao		2020-03-22	
sheet index		revision		A				dwg no	
		sheet		1~5				10162582	
								sheet 5 of 5	
								size	
								A3	
								type	
								Product Customer Drawing	