



## End-to-End Industrial Asset Monitoring Solution

- **Faster Monitoring:** Legacy assets can get connected and remotely monitored in minutes using Modbus RTU, 4 digital I/O & 2 analog inputs on iCast1.
- **Remote Control:** Control digital output(s) and write to MODBUS slave registers from web and mobile app.
- **Reduce Costs:** Enterprises can securely implement IoT capabilities at much lower up front cost without needing technical expertise.
- **Retrofit solution:** Industrial controls, commercial buildings, retail spaces and factories can be entirely retrofitted with IoT capabilities in days instead of months.
- **Work Smarter:** Continuously monitor, optimize the asset performance and maintain assets on a need-only basis.



### iCast1 IoT Bridge Model

Port Number	SL-IC1-M00-C
Modbus	RTU MASTER
Analog Input	2 Analog Inputs (0-10V / 4-20mA)
Digital IO's	4 Pins configured as Input / Output

### Wi-Fi Interface for Cloud Connectivity

Antenna	Internal PCB Antenna
Speed	802.11 b/g/n [up to 72.2 Mbps]
Protocols Supported	MQTT, HTTPS
Frequency	2.4 GHz

### Serial Interface

Port	4 Pin Pigtail Connector
Interface Mode	RS485
Supported Baud Rates	9600bps – 115.2 kbps
Parity	Odd, Even or None
Data Bits	8 bits
Stop Bits	1 or 2
Flow Control	None
Termination	Internal 130 ohm
ESD Protection	8 KV
Isolation Protection	NA
Serial Devices Supported	1 MODBUS SLAVE
Protocols Supported	MODBUS RTU MASTER

### Power Details

Power Consumption	Max 10W
Input Voltage	12 – 24 VDC
Max. Input Voltage Range	10 – 26 VDC
Reverse Power Protection	Yes
Overload Protection	No

### LED Indications

Wi-Fi LED	LED OFF – Wi-Fi not provisioned SLOW BLINK – Connecting to AP FAST BLINK – Connecting to Cloud LED ON – Connected to Cloud
PWR LED	LED OFF – Power OFF LED ON – Power ON
BLE LED (used for provisioning IoT Bridge)	LED OFF – BLE advertising stop SLOW BLINK – BLE advertising start LED ON – Connected to mobile app

### Environmental

Operating Temperature Range	-20 °C to +70 °C [-4 °F to +158 °F]
Storage Temperature Range	-40 °C to +85 °C [-40 °F to +185 °F]
Humidity	5 to 85% RH (non-condensing)
Protection Level	Plastic case, IP40
Agency Approvals	CE, FCC
EMI	EN 55032 Class A FCC Part 15 Subpart C (15.247)
EMS	IEC61000-4-2 (ESD): ±4kV (contact), ±8kV (air discharge) IEC 61000-4-3 (RS): 10V/m (80MHz-6GHz) IEC 61000-4-6 (CS): 10V (150KHz-80MHz)
Mechanical Standards	IEC60068-2-64 (Random Vibration) IEC60068-2-32 (Drop Test / Free Fall)

### Reset to Factory Defaults

Press and hold YELLOW button for 10 seconds to reset all settings to factory default.



## Dimensions

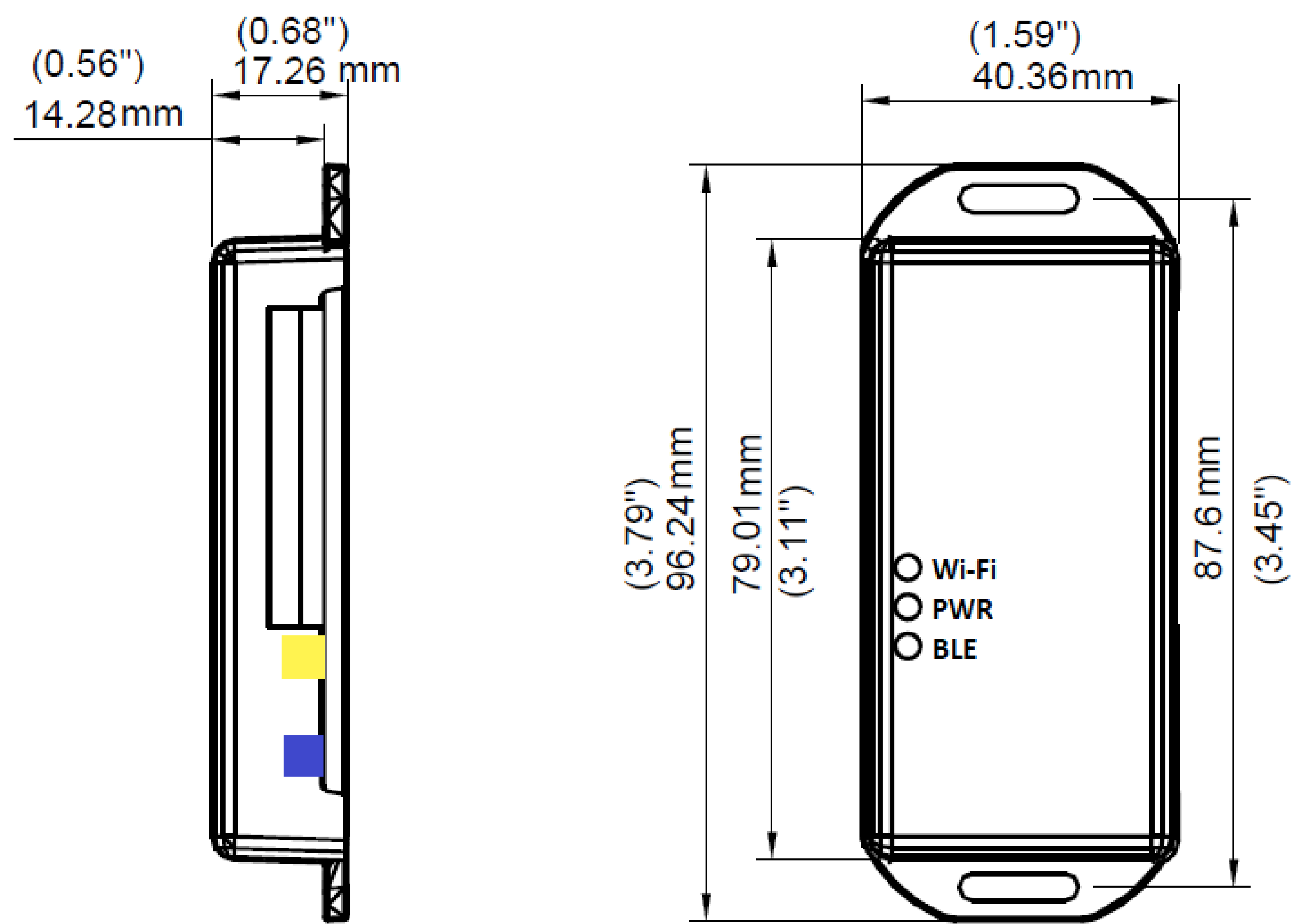

## Ports Details

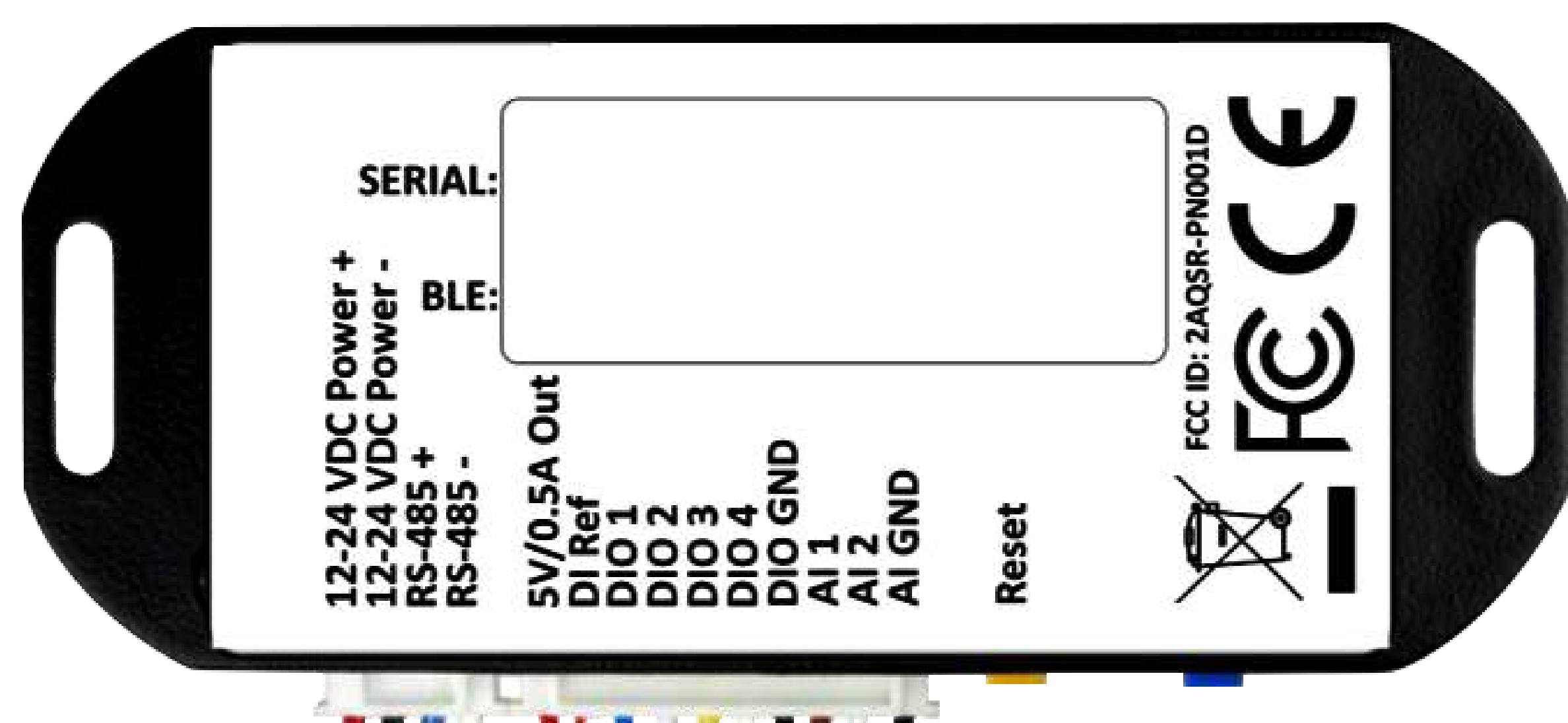

### Power Supply & Serial Port

Pin Name	Pin Function
12-24 VDC Power +	12-24 volts DC, positive terminal
12-24 VDC Power -	12-24 volts DC, negative terminal
RS-485 +	RS-485 positive terminal
RS-485 -	RS-485 negative terminal

### Input / Output Port

Pin Name	Pin Function
5V/0.5A Out	+5 Volts DC output @ 0.5amps
DI Ref	Digital Port Input reference (Range from 3.3V up to 24V)
DIO 1	Digital Input or Output 1
DIO 2	Digital Input or Output 2
DIO 3	Digital Input or Output 3
DIO 4	Digital Input or Output 4
DIO GND	Ground
AI 1	Analog Input 1 Signal (4-20mA/0-10V)
AI 2	Analog Input 2 Signal (4-20mA/0-10V)
AI GND	Ground

#### Note:

- Digital inputs are sinking and need a cold contact driving them.
- Digital outputs are 1A @ DI Ref Volts
- Analog inputs are 0-10VDC or 4-20 mA

## Safety Standards



## Quick Setup & Provisioning

- Mount iCast1 Wireless IoT Bridge
- Download Mobile App & Create Account
- Create a Device Profile from the Web App
- Provision the iCast1 to Your Account
- Requires iOS/Android smartphone with Bluetooth for provisioning and 2.4GHz AP with active internet connection
- For detailed instructions kindly refer to Quick Start Guide

## Cloud Subscription

- iCast1 IoT Bridge requires maintaining a monthly cloud subscription for providing long-term data storage, real-time monitoring and alert notifications. Subscription details at, <https://cloud.shorelineiot.com/pricing>

## Additional Help and Support:

- Please refer to the iCast1 IoT bridge User Manual for more detailed information.

## Connectivity

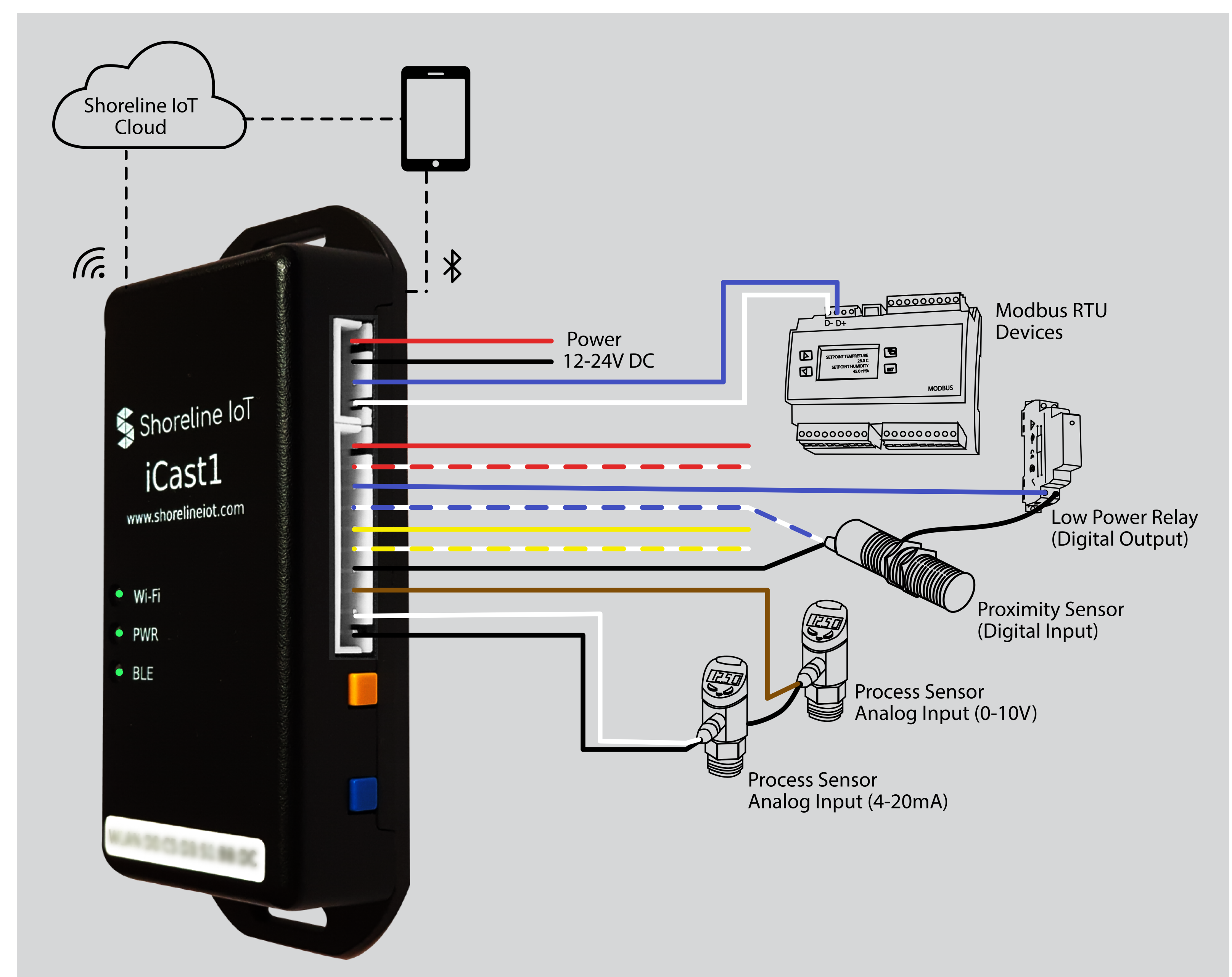

### Warning

- Disconnect power when wiring connections to the iCast1 unit
- Mount the iCast1 unit indoors only
- Avoid mounting inside a metal enclosure.