

**FineAdjust
Applicator**

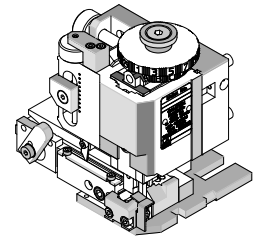

**Application Tooling
Specification Sheet**



Order No. 63901-1300

FEATURES

- Quick punch removal with the push of a button for fast and easy tooling change
- Applicator designed to industry standard mounting and shut height 135.80mm (5.346")
- Quick set-up time; plus the crimp height, track and feed adjustments can be set without removing the applicator from the press
- Fine adjustment allows users to achieve target with little effort by adjusting in increments of .015mm (.0006") for conductor crimp height and .063mm (.0025") for insulation height
- Independent adjustment rings allow users to quickly adjust the conductor or insulation crimp height without affecting each other
- Directly adapts to most automatic wire processing machines

SCOPE

Products: 1.20mm (.047") Pitch Pico-EZmate™ Wire-to-Board Crimp Terminal, 28-30 AWG.

Terminal Series No.	Terminal Order No.	Wire Size		Insulation Diameter				Strip Length	
				IPC/WHMA-A620 (1)		Terminal (2)			
		AWG	mm ²	mm	In.	mm	In.	mm	In.
✗ 78172	78172-0410 78172-0411	28-30	0.08-0.05	0.50-0.70	.020-.028	0.50-0.70	.020-.028	0.90-1.30	.035-.051

✗ Oiler is required for this applicator due to gold plating on terminal.
 Oiler order number 63801-7240 (See Part Number 63801-7240 on Molex Web)
 (1) To achieve optimum IPC-A620 insulation crimps, use this insulation OD range.
 (2) Overall insulation OD specification for terminal.

DEFINITION OF TERMS

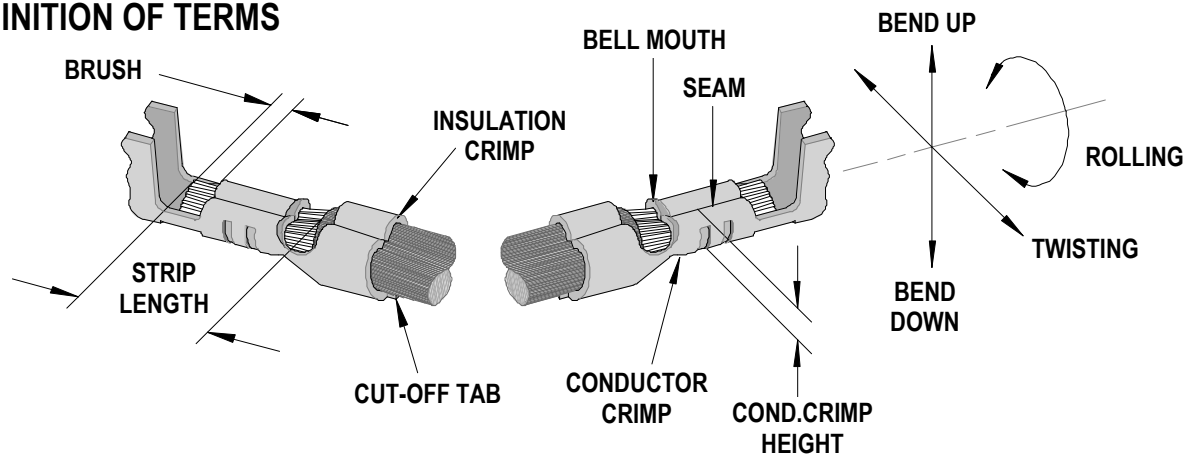

The above terminal drawing is a generic terminal representation. It is not an image of a terminal listed in the scope.

CRIMP SPECIFICATION

Terminal Series No.	Bell mouth		Cut-off Tab Maximum		Conductor Brush	
	mm	In.	mm	In.	mm	In.
78172	0.05-0.15	.002-.006	0.05	.002	0.15-0.70	.006-.028

Terminal Series No.	Bend up	Bend down	Twist	Roll	Punch Width mm (Ref)				Seam Seam shall not be open and no wire allowed out of the crimping area
					Conductor		Insulation		
	Degree (Max)		Degree (Max)		mm	In	mm	In	
78172	3	3	2	3	0.80	.031	0.80	.031	

After crimping, the conductor profile should measure the following.

Terminal Series No.	Wire Size		Conductor Crimp				Pull Force Minimum	
	AWG	mm ²	Crimp Height		Crimp Width (Ref.)		N	Lb.
			mm	In.	mm	In.		
78172	28	0.08	0.44-0.48	.017-.019	0.85	.033	10.0	2.25
	30	0.05	0.40-0.44	.015-.017	0.85	.033	5.0	1.12

Terminal Ordr No.	Wire Size		Insulation			
	AWG	mm ²	Crimp Height		Crimp Width (Ref.)	
			mm	In.	mm	In.
78172-0410	28	0.08	0.73-0.77	.028-.030	0.85	.033
	30	0.05	0.71-0.75	.027-.029	0.85	.033
78172-0411	28	0.08	0.77-0.81	.030-.032	0.85	.033
	30	0.05	0.75-0.79	.029-.031	0.85	.033

Pull Force should be measured with no influence from the insulation crimp.
The above specifications are guidelines to an optimum crimp.

PARTS LIST

FineAdjust Applicator 63901-1300				
Item	Order No	Engineering No.	Description	Quantity
Perishable Tooling				
	63901-1370	63901-1370	Tool Kit (All "Y" Items)	REF
1	63457-0046	63457-0046	Conductor Punch	1 Y
2	63455-0059	63455-0059	Conductor Anvil	1 Y
3	63454-0082	63454-0082	Insulation Punch	1 Y
4	63456-0054	63456-0054	Insulation Anvil	1 Y
5	63443-0005	63443-0005	Cut-Off Plunger	1 Y
6	63443-0012	63443-0012	Front Plunger Retainer	1 Y
Other Components				
7	63901-1301	63901-1301	Feed Guide	1
8	11-24-1067	4996-4	Cut-off Plunger Spring	1
9	11-40-4039	8302-5	Front Plunger Striker	1
10	63443-0009	63443-0009	Front Scrap Chute	1
11	63443-0025	63443-0025	Key	1
12	63443-0090	63443-0090	Wire Stop	1
13	63890-0058	63890-0058	Height Spacer	1
14	63443-2217	63443-2217	Coarse Spacer (17.00mm)	1
15	63443-2314	63443-2314	Fine Spacer (3.70mm)	1
16	63443-6101	63443-6101	Rear Cover	1
Frame				
17	63800-4901	63800-4901	Top	1
18	63801-3281	63801-3281	Base	1
19	63801-4650	63801-4650	Track	1
20	63820-7820	63820-7820	Feed Cam-Special	1
Hardware				
21	N/A	N/A	M3 by 6 Long SHCS	2**
22	N/A	N/A	M3 by 6 Long FHCS	1**
23	N/A	N/A	M4 by 6 Long SHCS	3**
24	N/A	N/A	M4 by 12 Long BHCS	2**
25	N/A	N/A	M4 by 50 Long SHCS	2**
26	N/A	N/A	M5 by 12 Long SHCS	1**
27	N/A	N/A	#10-32 by 3/8" Long Flat Point SSS	1**
28	N/A	N/A	#10-32 Hex Jam Nut	1**
** Available from an industrial supply company such as MSC (1-800-645-7270).				

Assembly Drawing

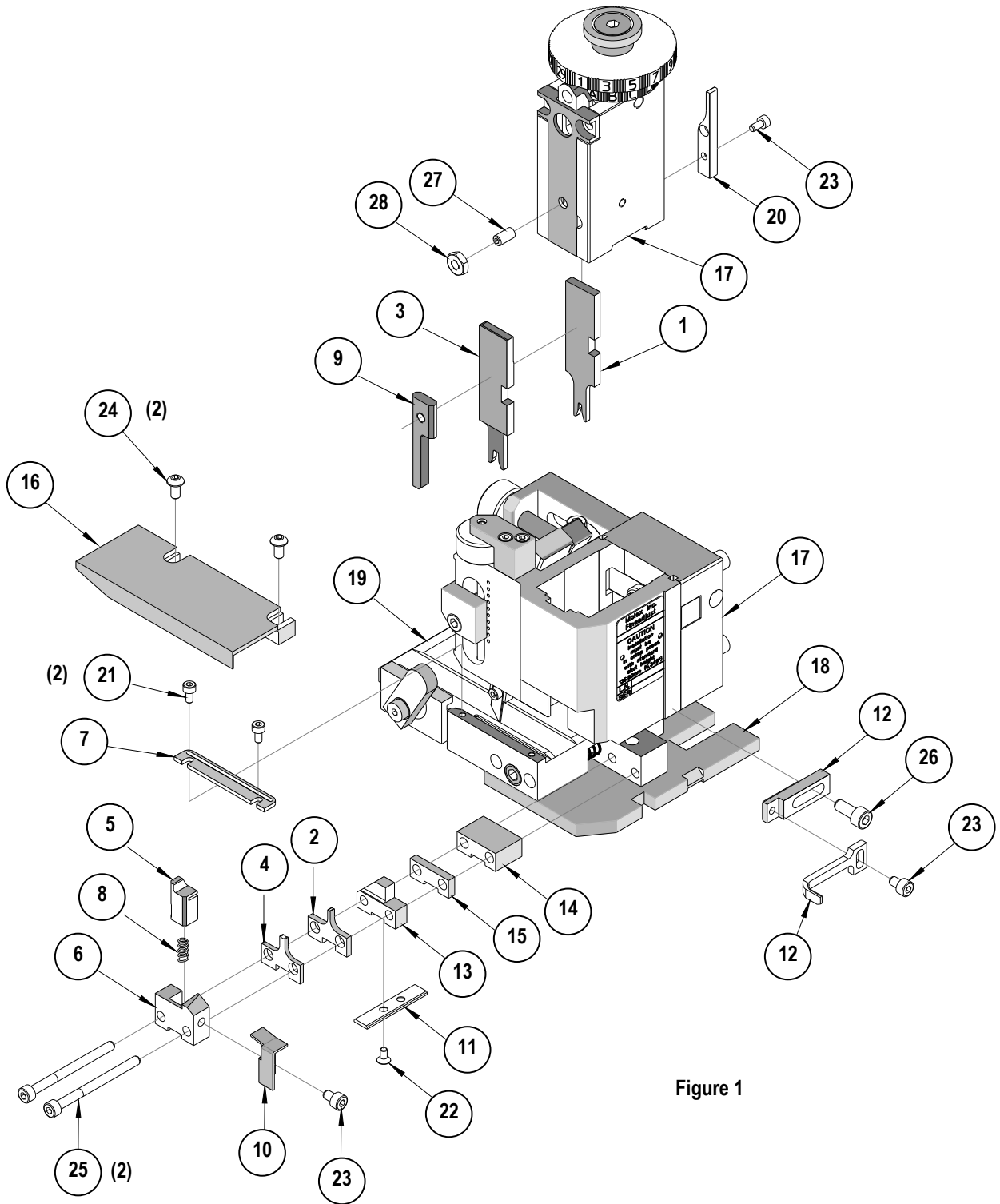

Figure 1

NOTES

1. Molex recommends an extra perishable tooling kit be maintained at your facility.
2. Verify tooling alignment by manually cycling the press and Applicator before crimping under power. Check that all screws are tight.
3. Slugs, Terminals, Dirt and Oil should be kept clear of work area.
4. Wear safety glasses at all times.
5. For recommended maintenance refer to the FineAdjust Manual.

CAUTION: This applicator should only be used in a press with a shut height of 135.8 mm (5.346"). Tooling damage could result at a lower setting.

CAUTION: To prevent injury never operate this Applicator without the guards supplied with the press or wire-processing machine in place. Reference the press or wire processing manufacturer's instruction manual.

CAUTION: Molex crimp specifications are valid only when used with Molex terminals, applicators and tooling.

<http://www.molex.com>