

PART NUMBER	REVISION	DESCRIPTION	FEED TYPE
2151432-1	E	FINE CRIMP HEIGHT ADJUST	MECHANICAL
2151432-2	F	FINE CRIMP HEIGHT ADJUST	PNEUMATIC
7-2151432-1	E	MECHANICAL AND CRIMP TOOLING KIT	MECHANICAL
7-2151432-2	F	PNEUMATIC AND CRIMP TOOLING KIT	PNEUMATIC
7-2151432-7	A	CRIMP TOOLING KIT	-

ATLANTIC VERSION TERMINATOR INTERFACE ADAPTER

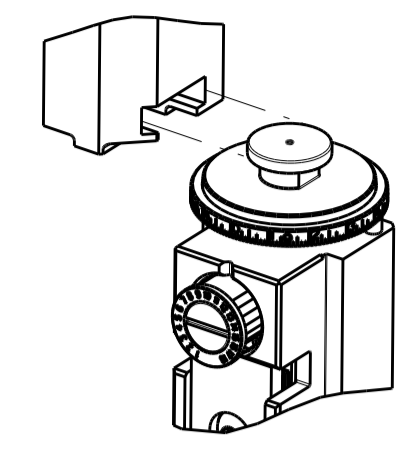

APPLICATOR DATA		
CRIMP	SIZE	TYPE
WIRE	1.40 mm [.055]	F
INSUL	1.70 mm [.067]	O

APPLICATOR INSTRUCTIONS 408-35042

TERMINAL DATA: MOLEX TERMINAL		MOLEX CRIMP SPECIFICATION	
TERMINAL NAME: TERMINAL, FEMALE BOX			
WIRE STRIP LENGTH		INSULATION DIAMETER RANGE	
3.17-3.56 mm [.125-.140 IN]		Ø1.40-1.63 mm [.055-.064 IN]	
TERMINAL APPLICATION SPECIFICATION		PS-70058	
TERMINALS APPLIED			
TE TERMINAL	MOLEX TERMINAL	TE TERMINAL	MOLEX TERMINAL
286981-1	16-02-0088	286981-8	16-02-0131
286981-2	16-02-0087	286981-9	70058-0086
286981-3	16-02-0086	1-286981-0	70058-0087
286981-4	16-02-1124	1-286981-1	70058-0088
286981-5	16-02-1111	1-286981-2	70058-4086
286981-6	16-02-1110	1-286981-3	70058-5001
286981-7	16-02-0103		

WIRE SIZE	CRIMP HEIGHT mm [INCH]	CRIMP HEIGHT REFERENCE SETTING
22 AWG OR 0.35mm2	0.865+/-0.025 [.034+/- .001]	8.1
24 AWG OR 0.20mm2	0.785+/-0.025 [.0309+/- .0010]	8.9

- 1 RECOMMENDED SPARE PARTS
- 2 REFER TO SUPPLIED INSTRUCTION SHEET FOR CLEANING, LUBRICATION AND STORAGE OF APPLICATOR.
- 3 APPLY PART NUMBER 2-23419-6 LOCTITE TO THREADS OF ITEM 242.
- 4 CRIMP HEIGHT REFERENCE SETTING WAS THE SETTING USED WHEN THE APPLICATOR WAS QUALIFIED AT THE FACTORY. ADJUSTMENT MAY BE NECESSARY WHEN RUNNING APPLICATOR IN THE FIELD.
- 5. UNLESS SPECIFIED OTHERWISE TORQUE VALUES SHALL BE USED PER DOCUMENT, 101-35000.

***WARNING**
ON INSTALLATION, SET WIRE DISC TO CRIMP HEIGHT REFERENCE SETTING FOR LARGEST WIRE SIZE. CRIMP HEIGHT REFERENCE SETTINGS GREATER THAN THE VALUE SHOWN MAY CAUSE DAMAGE TO THE CRIMP TOOLING. REFER TO THE INSTRUCTION SHEET FOR PROPER SETUP AND ADJUSTMENTS.

ATLANTIC VERSION
Shown on sheets 1 of 4 & 2 of 4
(Pacific version shown on sheets 3 of 4 & 4 of 4)

LOC	DIST	REVISIONS					
A	66	P	LTN	DESCRIPTION	DATE	OWN	APVD
		C		ECR-15-018772	30DEC2015	MR	GB
		D		ECR-18-012381	03AUG2018	FZ	KZ
		E		ECR-18-016100	11OCT2018	TB	CT
		F		ECR-19-010979	15JUL2019	FZ	TE

-	1	1	1	1	2119791-6	DEPRESSOR, WIRE	286	
-	1	1	1	1	2280441-1	INSERT, SHEAR	282	
-	1	-	1	-	2119641-1	FEED CAM, AIR FEED	248	
-	1	1	1	1	2119082-9	CAM, SNAIL, INSULATION ADJUSTMENT	244	
-	1	1	1	1	2079764-1	WASHER, WAVE SPRING, CREST-TO-CREST	243	
-	1	1	1	1	2119083-1	RETAINER, INSULATION DIAL	242	
-	2	2	2	2	7-18023-7	SCR, SKT HD CAP M3 X 4.0	241	
-	-	1	-	1	2119580-1	MECHANICAL FEED ASSEMBLY	239	
-	1	-	1	-	2844940-1	AIR FEED MODULE	238	
-	1	1	1	1	1-356885-5	STOP, SHEAR	237	
-	REF	REF	REF	REF	994970-2	COUNTER, MAGNETIC	164	
-	1	1	1	1	2168083-6	SCR, SKT HD CAP, RoHS, M5 X 65	124	
-	1	1	1	1	2844908-1	SCREW, LOCKING	99	
-	1	1	1	1	2844907-1	POST, LOCKING	98	
-	1	1	1	1	1-22281-8	SPRING, COMPRESSION	96	
-	1	1	1	1	980371-4	SCR, SKT HD SHLDR 5.0 DIA X 6.0	83	
-	1	1	1	1	455888-6	SPACER, CRIMPER	82	
-	1	1	1	1	8-240641-4	SPACER	81	
-	1	1	1	1	1803607-3	DOCUMENTATION PACKAGE	71	
-	1	1	1	1	2119791-5	DEPRESSOR, WIRE	70	
-	1	1	1	1	2119943-1	WASHER, SPACER	69	
-	1	1	1	1	2119740-1	TAG, IDENTIFICATION	67	
-	2	2	2	2	2168078-1	SCREW, DRIVE, RH, RoHS, 2 x .188	66	
-	4	4	4	4	2168083-1	SCR, SKT HD CAP, RoHS, M3 X 8.0	65	
-	2	2	2	2	2-18032-5	SCR, SET, FLT PNT, M5 X 20.0	61	
-	1	1	1	1	2168083-2	SCR, SKT HD CAP, RoHS, M4 X 8.0	60	
-	1	1	1	1	5-18022-5	SCR, HEX HD CAP, M4 X 6.0	59	
-	1	1	1	1	1338683-1	FEED PAWL	56	
-	4	4	4	4	2168083-3	SCR, SKT HD CAP, RoHS, M4 X 12.0	54	
-	2	2	2	2	2-2168083-6	SCR, SKT HD CAP, RoHS, M4 X 18	53	
-	1	2	1	2	18023-9	SCR, SKT HD CAP M4 X 6.0	49	
-	-	1	-	1	2119652-1	FEED CAM, PRE FEED	48	
-	-	1	-	1	2119653-1	FEED CAM, POST FEED	47	
-	1	1	1	1	1803583-9	APPLICATOR BASIC ASSEMBLY, SF	46	
-	1	1	1	1	1803515-1	RAM ASSEMBLY, SF ATLANTIC	44	
-	1	1	1	1	1803602-1	SCR, BHSC, RoHS (M8 X 25)	41	
-	1	1	1	1	2305692-1	PLATE, REAR STRIP GUIDE	29	
-	1	1	1	1	455888-1	SPACER, CRIMPER	28	
-	2	2	2	2	1-22284-0	SPRING, COMPRESSION	27	
-	1	1	1	1	356835-1	LEVER, DRAG RELEASE	26	
-	1	1	1	1	240792-1	DRAG, TERMINAL	25	
-	1	1	1	1	189124-7	GUIDE, FRONT STRIP	24	
-	1	1	1	1	690438-1	FRONT STRIP GUIDE	23	
-	1	1	1	1	2168083-2	SCR, SKT HD CAP, RoHS, M4 X 8.0	21	
-	3	3	3	3	1-18028-2	WASHER, FLAT, REG M4	20	
-	1	1	1	1	2119533-1	STRIPPER, SIDE FEED	19	
-	1	1	1	1	2-690518-4	HOLD DOWN, TERMINAL	18	
-	1	1	1	1	690463-1	FLOATING SHEAR, REAR	17	
-	2	2	2	2	1-2168083-1	SCR, SKT HD CAP, RoHS, M3 X 6	16	
-	1	1	1	1	1-690464-4	SHEAR PLATE, REAR	15	
-	1	1	1	1	2119862-1	SHEAR HOLDER, REAR	14	
-	1	1	1	1	2119806-1	INSERT, SHEAR	13	
-	2	2	2	2	3-22280-3	SPRING, COMPRESSION	12	
-	1	1	1	1	1-356885-4	STOP, SHEAR	11	
-	1	1	1	1	2119805-1	SHEAR HOLDER, FRONT	10	
-	1	1	1	1	1803095-3	FLOATING SHEAR, FRONT	9	
-	1	2	2	1	1	3-1633621-8	ANVIL, COMBINATION	8
-	1	1	1	1	240641-4	SPACER	7	
-	1	1	1	1	690468-2	DEPRESSOR SHEAR, REAR	6	
-	1	1	1	1	2119757-4	DEPRESSOR, SHEAR	5	
-	1	1	1	1	238011-6	BLOCK, CRIMPER SPACER	4	
-	1	2	2	1	1	2-1803019-0	CRIMPER, INSULATION O	3
-	-	-	-	-	-	-	2	
-	1	2	2	1	1	5-456402-4	CRIMPER, WIRE PREMIUM	1
-	77	72	71	-2	-1	PART NO	DESCRIPTION	ITEM NO

DIMENSIONS:		TOLERANCES UNLESS OTHERWISE SPECIFIED:		MATERIAL:		FINISH:	
mm	0 PLC ±	1 PLC ±	2 PLC ±	3 PLC ±	4 PLC ±	ANGLES ±	

OWN	Y. YIN	22MAY2012	TE Connectivity Harrisburg, PA 17105-3608
CHK	G. BAILEY	22MAY2012	
APVD	S. XI	22MAY2012	NAME
PRODUCT SPEC			Ocean Side Feed Applicator
APPLICATION SPEC			
SIZE	CAGE CODE	DRAWING NO	RESTRICTED TO
A1	00779	2151432	
Customer Accessible Production Drawing			SCALE 1:2 SHEET 1 OF 4 REV F

LOC	DIST	REV	DATE	BY	APPV
A	66				

FEED TYPE MECHANICAL

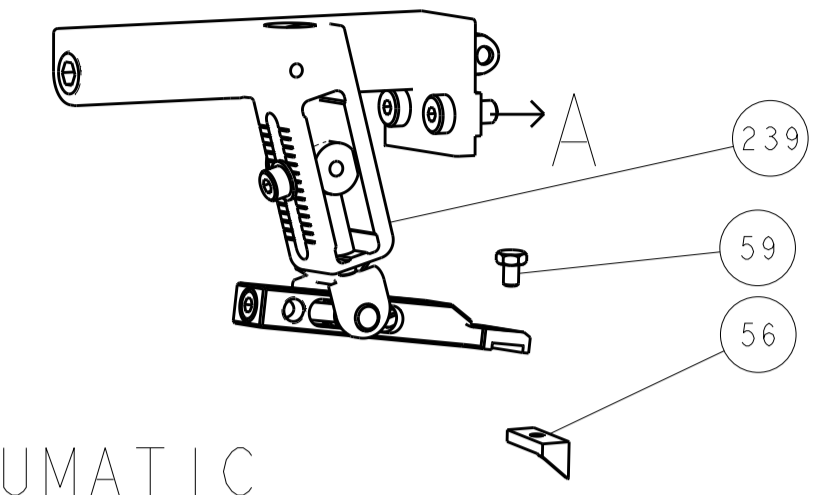

PNEUMATIC

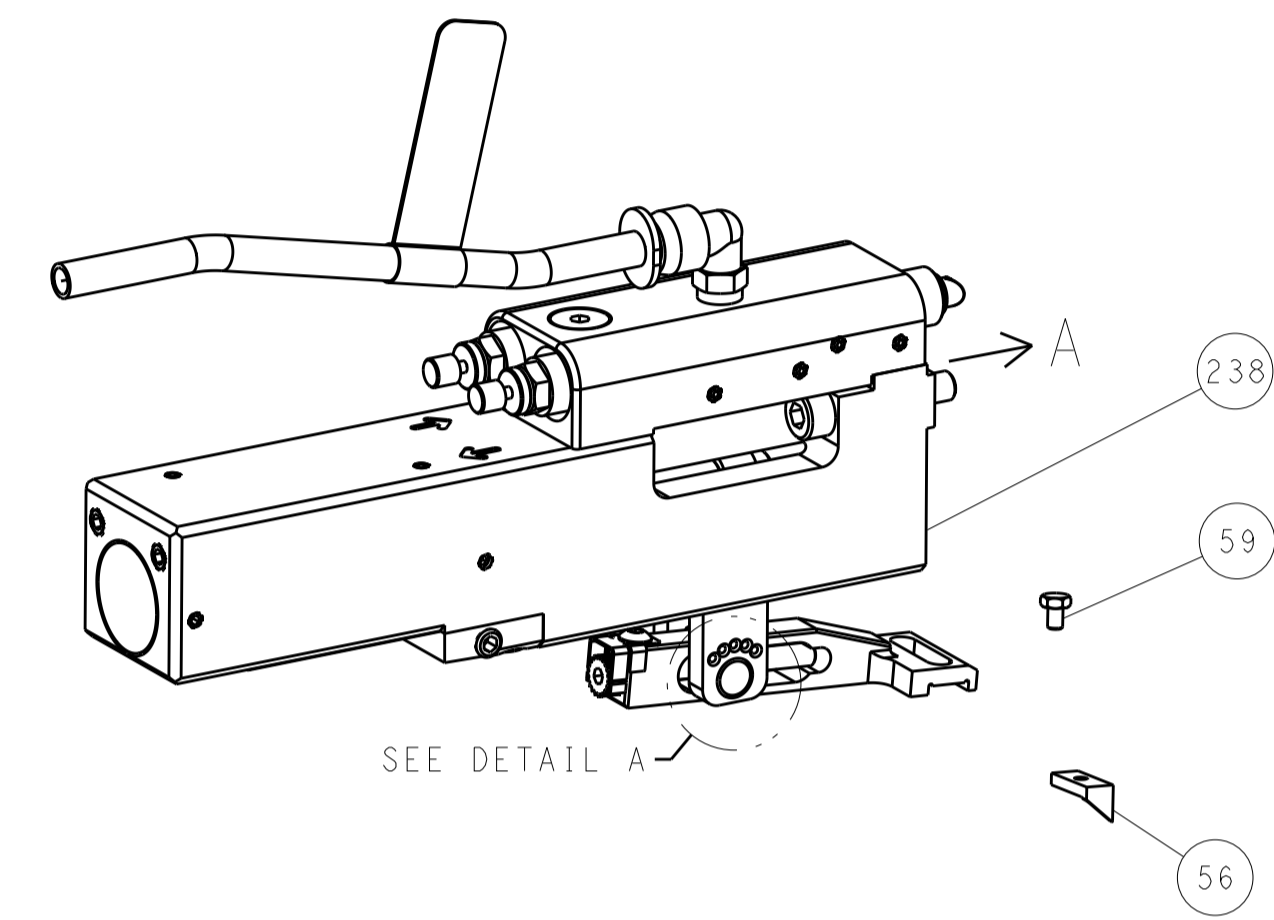

FEED SPRING SETTING POSITION (SHOWN FROM REAR SIDE)

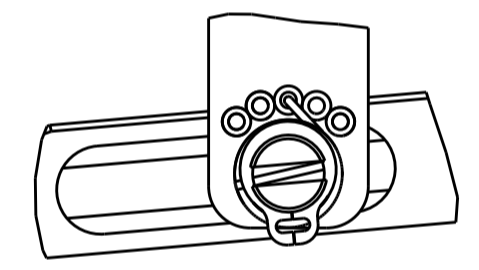

DETAIL A

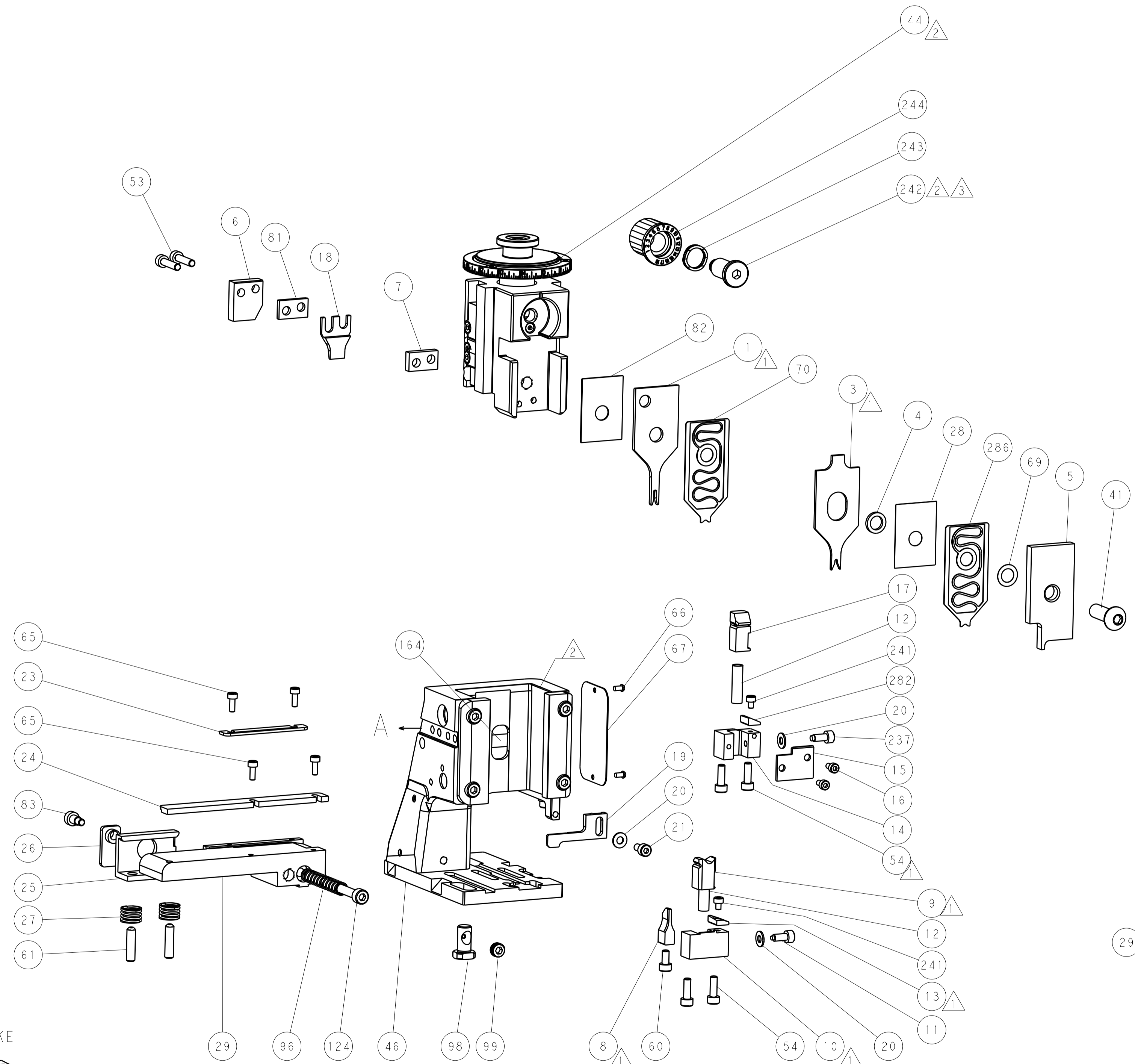

CAM POSITIONS

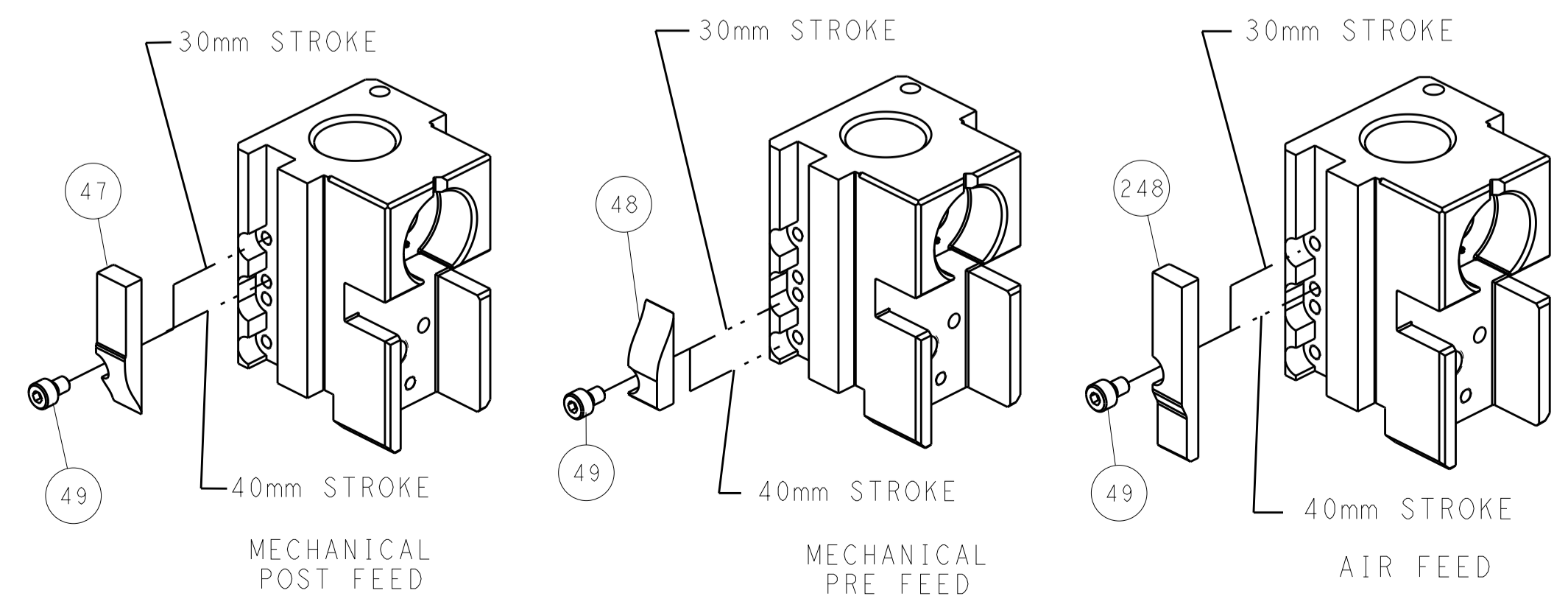

ATLANTIC VERSION
 Shown on sheets 1 of 4 & 2 of 4
 (Pacific version shown on sheets 3 of 4 & 4 of 4)

DIMENSIONS: mm 		TOLERANCES UNLESS OTHERWISE SPECIFIED: 0 PLC ± 1 PLC ± 2 PLC ± 3 PLC ± 4 PLC ± ANGLES ±		DWN: Y. YIN 22MAY2012 CHK: G. BAILEY 22MAY2012 APPV: S. XI 22MAY2012 NAME: Ocean Side Feed Applicator SIZE: A1 CAGE CODE: 00779 DRAWING NO: 2151432 SCALE: 1:2 SHEET: 2 OF 4 REV: F	
MATERIAL:		FINISH:		WEIGHT:	

FEED TRACK POSITION GUIDE BY INSULATION BARREL

PART NUMBER	REVISION	DESCRIPTION	FEED TYPE
2-2151432-1	E	FINE CRIMP HEIGHT ADJUST	MECHANICAL
2-2151432-2	F	FINE CRIMP HEIGHT ADJUST	PNEUMATIC
7-2151432-7	A	CRIMP TOOLING KIT	-

PACIFIC VERSION TERMINATOR
 INTERFACE ADAPTER

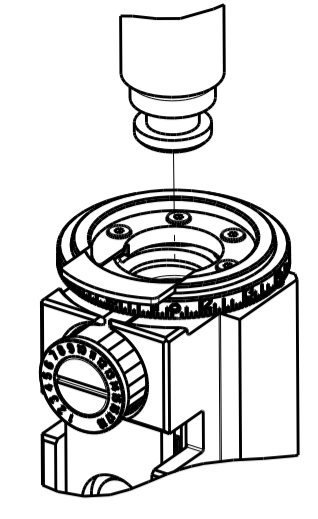

APPLICATOR DATA		
CRIMP	SIZE	TYPE
WIRE	1.40 mm [.055]	F
INSUL	1.70 mm [.067]	O

APPLICATOR INSTRUCTIONS
 408-35042

TERMINAL DATA: MOLEX TERMINAL		MOLEX CRIMP SPECIFICATION	
TERMINAL NAME: TERMINAL, FEMALE BOX			
WIRE STRIP LENGTH		INSULATION DIAMETER RANGE	
3.17-3.56 mm [1.25-.140 IN]		Ø1.40-1.63 mm [.055-.064 IN]	
TERMINAL APPLICATION SPECIFICATION	PS-70058		
TERMINALS APPLIED			
TE TERMINAL	MOLEX TERMINAL	TE TERMINAL	MOLEX TERMINAL
286981-1	16-02-0088	286981-8	16-02-0131
286981-2	16-02-0087	286981-9	70058-0086
286981-3	16-02-0086	1-286981-0	70058-0087
286981-4	16-02-1124	1-286981-1	70058-0088
286981-5	16-02-1111	1-286981-2	70058-4086
286981-6	16-02-1110	1-286981-3	70058-5001
286981-7	16-02-0103		

WIRE SIZE	CRIMP HEIGHT mm [INCH]	CRIMP HEIGHT REFERENCE SETTING
22 AWG OR 0.35mm2	0.865+/-0.025 [.034+/- .001]	8.1
24 AWG OR 0.20mm2	0.785+/-0.025 [.0309+/- .0010]	8.9

- 1 RECOMMENDED SPARE PARTS
- 2 REFER TO SUPPLIED INSTRUCTION SHEET FOR CLEANING, LUBRICATION AND STORAGE OF APPLICATOR.
- 3 APPLY PART NUMBER 2-23419-6 LOCTITE TO THREADS OF ITEM 242.
- 4 CRIMP HEIGHT REFERENCE SETTING WAS THE SETTING USED WHEN THE APPLICATOR WAS QUALIFIED AT THE FACTORY. ADJUSTMENT MAY BE NECESSARY WHEN RUNNING APPLICATOR IN THE FIELD.
- 5. UNLESS SPECIFIED OTHERWISE TORQUE VALUES SHALL BE USED PER DOCUMENT, 101-35000.

***WARNING**
 ON INSTALLATION, SET WIRE DISC TO CRIMP HEIGHT REFERENCE SETTING FOR LARGEST WIRE SIZE. CRIMP HEIGHT REFERENCE SETTINGS GREATER THAN THE VALUE SHOWN MAY CAUSE DAMAGE TO THE CRIMP TOOLING. REFER TO THE INSTRUCTION SHEET FOR PROPER SETUP AND ADJUSTMENTS.

LOC	DIST	REVISIONS					
A	66	P	LTN	DESCRIPTION	DATE	OWN	APVD
-	-	-	-	SEE SHEET 1	-	-	-

-	1	1	2119791-6	DEPRESSOR, WIRE	286
1	-	1	2280441-1	INSERT, SHEAR	282
-	1	1	2119082-9	CAM, SNAIL, INSULATION ADJUSTMENT	244
-	1	1	2079764-1	WASHER, WAVE SPRING, CREST-TO-CREST	243
3	-	1	2119083-1	RETAINER, INSULATION DIAL	242
-	2	2	7-18023-7	SCR, SKT HD CAP M3 X 4.0	241
-	-	1	2119580-1	MECHANICAL FEED ASSEMBLY	239
-	1	-	2844940-1	AIR FEED MODULE	238
-	1	1	1-356885-5	STOP, SHEAR	237
-	REF	REF	994970-2	COUNTER, MAGNETIC	164
-	1	-	2119641-2	FEED CAM, AIR FEED	151
-	1	1	2168083-8	SCR, SKT HD CAP, RoHS, M4 X 16	144
-	4	4	2168083-9	SCR, SKT HD CAP, RoHS, M4 X 20	143
-	-	1	2119653-2	FEED CAM, POST FEED	142
-	1	1	1-1803583-0	APPLICATOR BASIC ASSEMBLY, SF	141
-	1	1	1803516-1	RAM ASSEMBLY, SF PACIFIC	140
-	1	1	2168083-6	SCR, SKT HD CAP, RoHS, M5 X 65	124
-	1	1	2844908-1	SCREW, LOCKING	99
-	1	1	2844907-1	POST, LOCKING	98
-	1	1	1-22281-8	SPRING, COMPRESSION	96
-	1	1	980371-4	SCR, SKT HD SHLDR 5.0 DIA X 6.0	83
-	1	1	455888-6	SPACER, CRIMPER	82
-	1	1	8-240641-4	SPACER	81
-	1	1	1803607-3	DOCUMENTATION PACKAGE	71
-	1	1	2119791-5	DEPRESSOR, WIRE	70
-	1	1	2119943-1	WASHER, SPACER	69
-	1	1	2119740-1	TAG IDENTIFICATION	67
-	2	2	2168078-1	SCREW, DRIVE, RH, RoHS, 2 x .188	66
-	4	4	2168083-1	SCR, SKT HD CAP, RoHS, M3 X 8.0	65
-	2	2	2-18032-5	SCR, SET, FLT PNT, M5 X 20.0	61
-	1	1	5-18022-5	SCR, HEX HD CAP, M4 X 6.0	59
-	1	1	1338683-1	FEED PAWL	56
-	2	2	2-2168083-6	SCR, SKT HD CAP, RoHS, M4 X 18	53
-	1	2	18023-9	SCR, SKT HD CAP M4 X 6.0	49
-	-	1	2119652-1	FEED CAM, PRE FEED	48
-	1	1	1803602-1	SCR, BHSC, RoHS (M8 X 25)	41
-	1	1	2305692-1	PLATE, REAR STRIP GUIDE	29
-	1	1	455888-1	SPACER, CRIMPER	28
-	2	2	1-22284-0	SPRING, COMPRESSION	27
-	1	1	356835-1	LEVER, DRAG RELEASE	26
-	1	1	240792-1	DRAG, TERMINAL	25
-	1	1	189124-7	GUIDE, FRONT STRIP	24
-	1	1	690438-1	FRONT STRIP GUIDE	23
-	1	1	2168083-2	SCR, SKT HD CAP, RoHS, M4 X 8.0	21
-	3	3	1-18028-2	WASHER, FLAT, REG M4	20
-	1	1	2119533-1	STRIPPER, SIDE FEED	19
-	1	1	2-690518-4	HOLD DOWN, TERMINAL	18
-	1	1	690463-1	FLOATING SHEAR, REAR	17
-	2	2	1-2168083-1	SCR, SKT HD CAP, RoHS, M3 X 6	16
-	1	1	1-690464-4	SHEAR PLATE, REAR	15
-	1	1	2119862-1	SHEAR HOLDER, REAR	14
-	1	1	2119806-1	INSERT, SHEAR	13
-	2	2	3-22280-3	SPRING, COMPRESSION	12
-	1	1	1-356885-4	STOP, SHEAR	11
-	1	1	2119805-1	SHEAR HOLDER, FRONT	10
-	1	1	1803095-3	FLOATING SHEAR, FRONT	9
-	1	1	3-1633621-8	ANVIL, COMBINATION	8
-	1	1	240641-4	SPACER	7
-	1	1	690468-2	DEPRESSOR SHEAR, REAR	6
-	1	1	2119757-4	DEPRESSOR, SHEAR	5
-	1	1	238011-6	BLOCK, CRIMPER SPACER	4
-	1	1	2-1803019-0	CRIMPER, INSULATION O	3
-	-	-	-	-	2
-	1	1	5-456402-4	CRIMPER, WIRE PREMIUM	1

PACIFIC VERSION
 Shown on sheets 3 of 4 & 4 of 4
 (Atlantic version shown on sheets 1 of 4 & 2 of 4)

DIMENSIONS:		TOLERANCES UNLESS OTHERWISE SPECIFIED:		OTHERWISE SPECIFIED:	
mm	0 PLC ±	1 PLC ±	2 PLC ±	3 PLC ±	4 PLC ±
	ANGLES	FINISH			

DATE	22MAY2012	OWN	Y. YIN
CHK	22MAY2012	CHK	G. BAILEY
APVD	22MAY2012	APVD	S. XI
PRODUCT SPEC		APPLICATION SPEC	
SIZE	A1	CAGE CODE	00779
DRAWING NO	2151432	SCALE	1:2
SHEET	3	OF	4
REV	F		

Customer Accessible Production Drawing

LOC		DIST		REVISIONS			
A	66	P	LTM	DESCRIPTION	DATE	DWN	APVD
		-		SEE SHEET 1			

FEED TYPE MECHANICAL

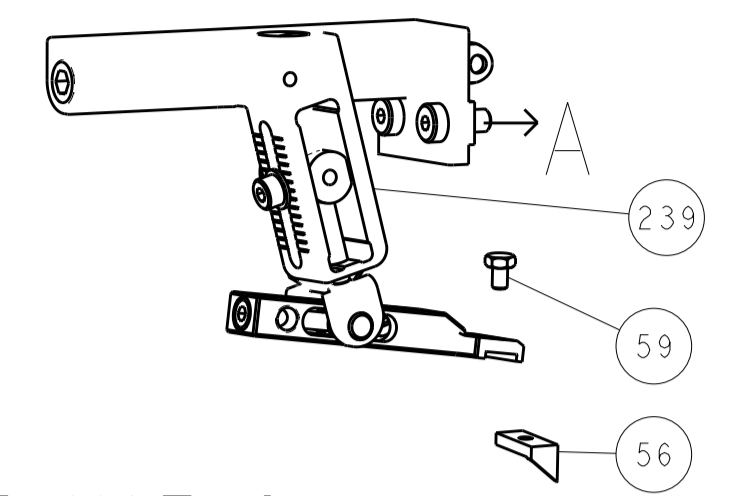

PNEUMATIC

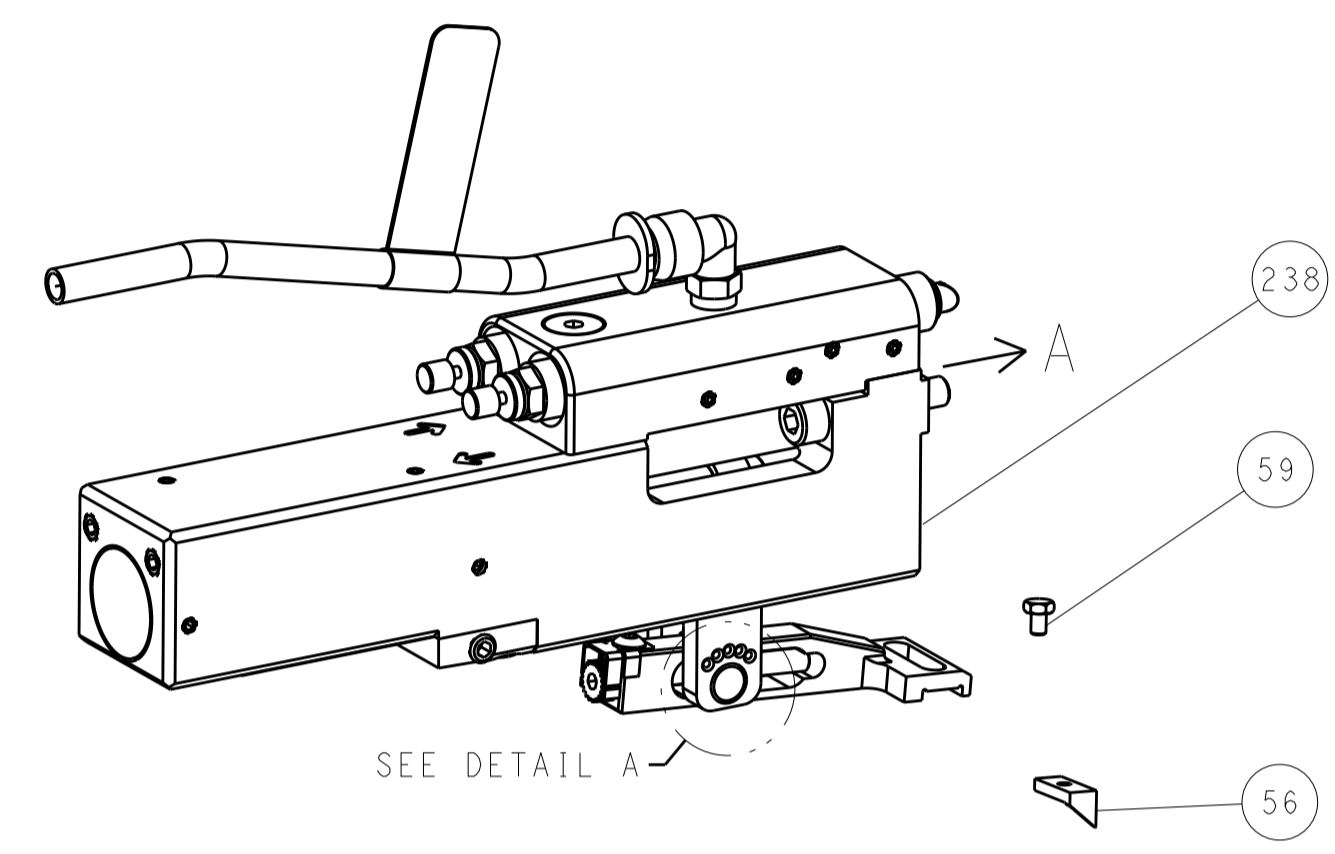

FEED SPRING SETTING POSITION (SHOWN FROM REAR SIDE)

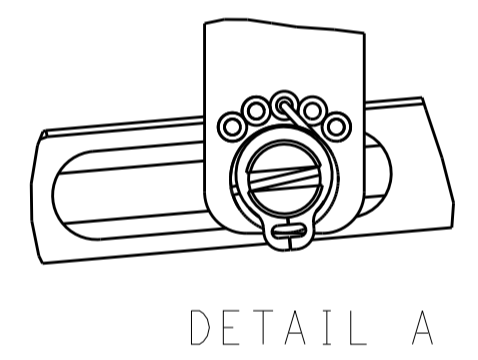

CAM POSITIONS

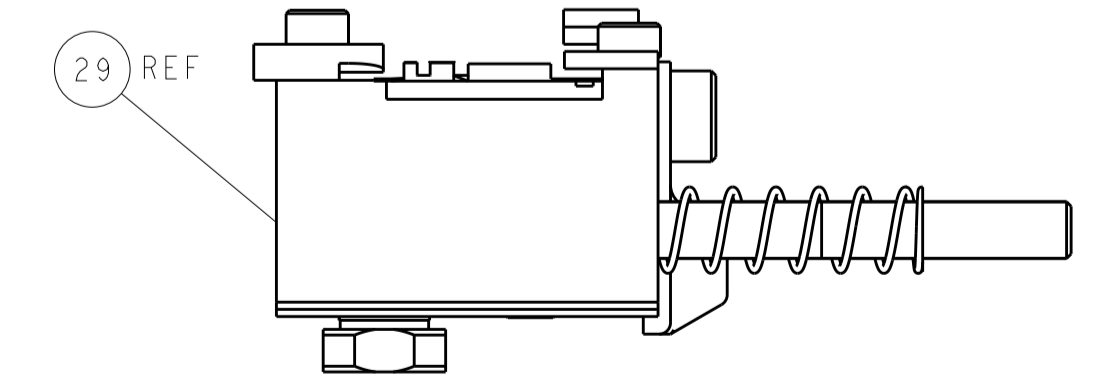
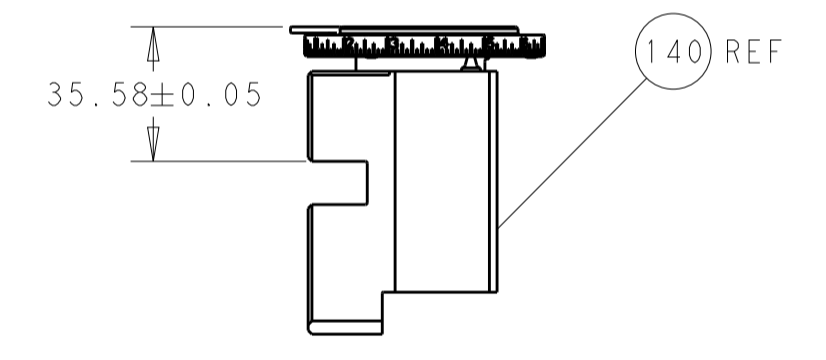
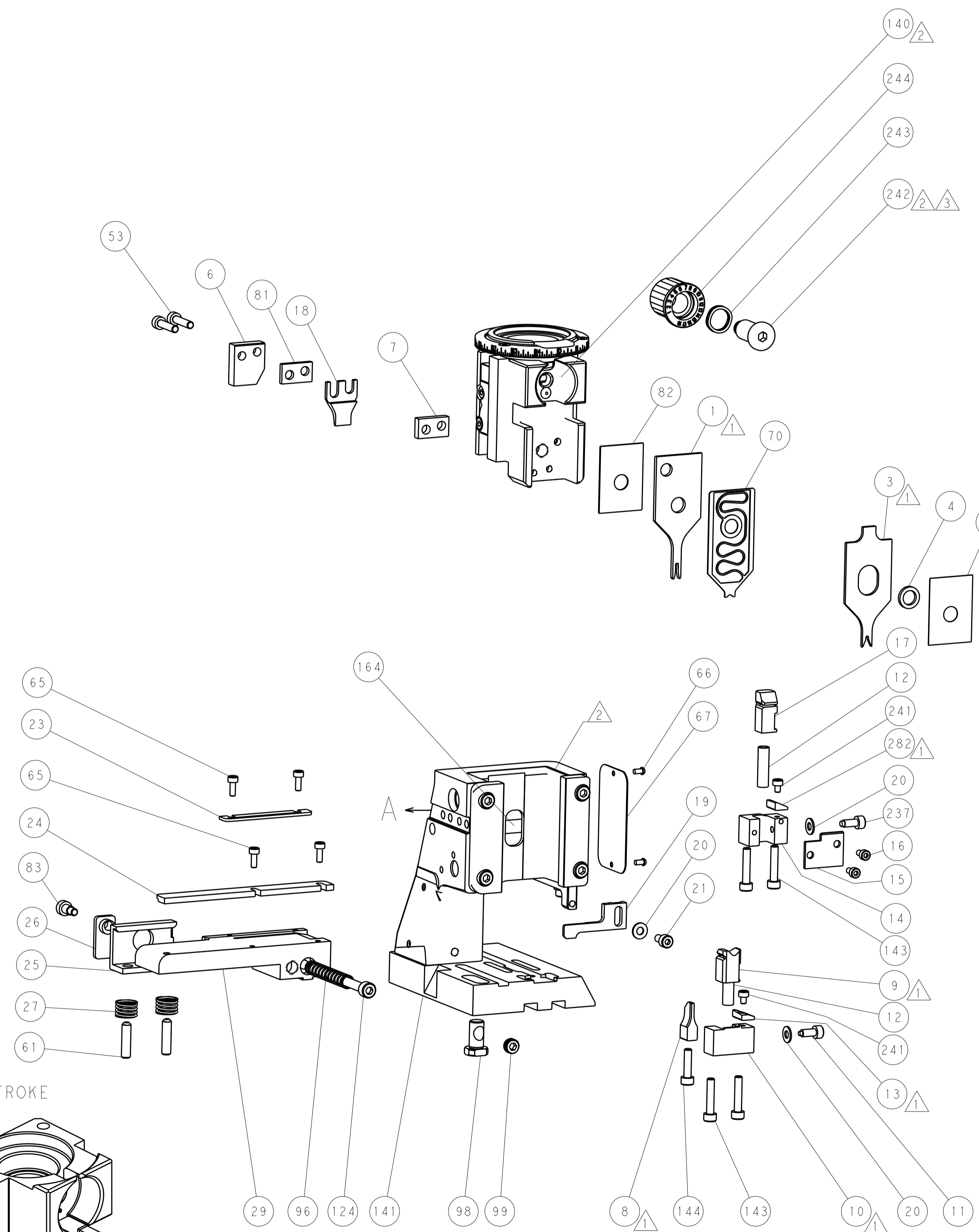
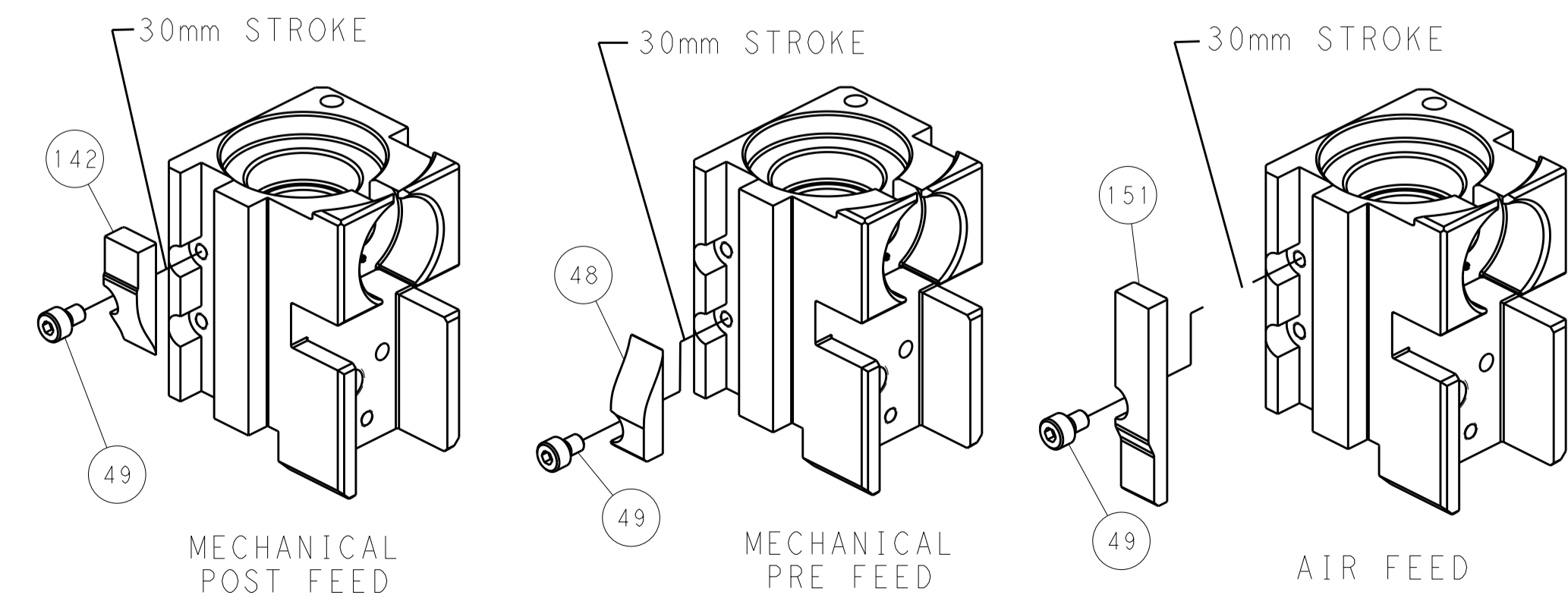

PACIFIC VERSION
 Shown on sheets 3 of 4 & 4 of 4
 (Atlantic version shown on sheets 1 of 4 & 2 of 4)

DIMENSIONS:		TOLERANCES UNLESS OTHERWISE SPECIFIED:		DWN Y. YIN 22MAY2012		TE Connectivity	
mm	0 PLC ±	1 PLC ±	2 PLC ±	3 PLC ±	4 PLC ±	Harrisburg, PA 17105-3608	
MATERIAL:		FINISH:		CHK G. BAILEY 22MAY2012		NAME Ocean Side Feed Applicator	
				S. XI 22MAY2012		SIZE CAGE CODE DRAWING NO RESTRICTED TO	
				APVD		Customer Accessible Production Drawing	
				WEIGHT		SCALE 1:2 SHEET 4 OF 4 REV F	
				A 00779 ©=2151432			