

SAFETY PRECAUTIONS	READ THIS FIRST!	2
1. INTRODUCTION		3
2. DESCRIPTION		4
2.1. Major Groups		5
2.2. Switches and Controls		11
2.3. Functional Description		12
3. RECEIVING INSPECTION AND INSTALLATION		12
3.1. Receiving Inspection		12
3.2. Considerations Affecting Terminator Placement		13
3.3. Installation		14
4. SETUP		14
4.1. Pre-Loading Alignment Check		14
4.2. Tooling Alignment Procedure		15
4.3. Terminal Strip Loading		16
4.4. Terminator Checkout		18
4.5. Termination Inspection		19
5. PRODUCTION OPERATION		20
6. ADJUSTMENTS		21
6.1. Crimp Height Adjustment (Tooling Increments)		21
6.2. Feed Adjustments		21
6.3. Adjustment of Ram and Feed Switches		28
7. PREVENTIVE MAINTENANCE		29
8. ERROR CODES AND I/O SCREEN		30
8.1. Error Codes		30
8.2. I/O Screen		31
9. REPLACEMENT AND REPAIR		31
9.1. Splice Terminators		31
9.2. Direct Connect Terminators		32
10. OPTIONAL WIRE STUFFER ASSEMBLY		34
10.1. Wire Stuffer Assembly Installation		34
10.2. Wire Stuffer Assembly Adjustment		35
10.3. Operation		36
10.4. Maintenance		36
11. optional infinite splice assembly		37
11.1. Infinite Splice Assembly Installation		38
11.2. Infinite Splice Assembly Adjustment		38
11.3. Operation		39
11.4. Maintenance		39
12. REVISION SUMMARY		39

SAFETY PRECAUTIONS — AVOID INJURY

Safeguards are designed into this application equipment to protect operators and maintenance personnel from most hazards during equipment operation. However, certain safety precautions must be taken by the operator and repair personnel to avoid personal injury, as well as damage to the equipment. For best results, application equipment must be operated in a dry, dust-free environment. Do not operate equipment in a gaseous or hazardous environment.

Carefully observe the following safety precautions before and during operation of the equipment:



Always wear approved eye protection while operating equipment.



Always turn off the main power switch and disconnect the electrical cord from the power source when performing repair or maintenance on the equipment.



Always wear appropriate ear protection while using equipment.



Never insert hands into installed equipment. Never wear loose clothing or jewelry that may catch in moving parts of the equipment.



Moving parts can crush and cut. Always keep guard(s) in place during normal operation.



Never alter, modify, or misuse the equipment.



Electrical shock hazard.

TOOLING ASSISTANCE CENTER

CALL TOLL FREE 1-800-722-1111 (CONTINENTAL UNITED STATES AND PUERTO RICO ONLY)

The **Tooling Assistance Center** offers a means of providing technical assistance when required.

In addition, Field Service Specialists are available to provide assistance in the adjustment or repair of the application equipment when problems arise which your maintenance personnel are unable to correct.

INFORMATION REQUIRED WHEN CONTACTING THE TOOLING ASSISTANCE CENTER

When calling the Tooling Assistance Center regarding service to equipment, it is suggested that a person familiar with the device be present with a copy of the manual (and drawings) to receive instructions. Many difficulties can be avoided in this manner.

When calling the Tooling Assistance Center, be ready with the following information:

1. Customer name
2. Customer address
3. Person to contact (name, title, telephone number, and extension)
4. Person calling
5. Equipment number (and serial number if applicable)
6. Product part number (and serial number if applicable)
7. Urgency of request
8. Nature of problem
9. Description of inoperative component(s)
10. Additional information/comments that may be helpful

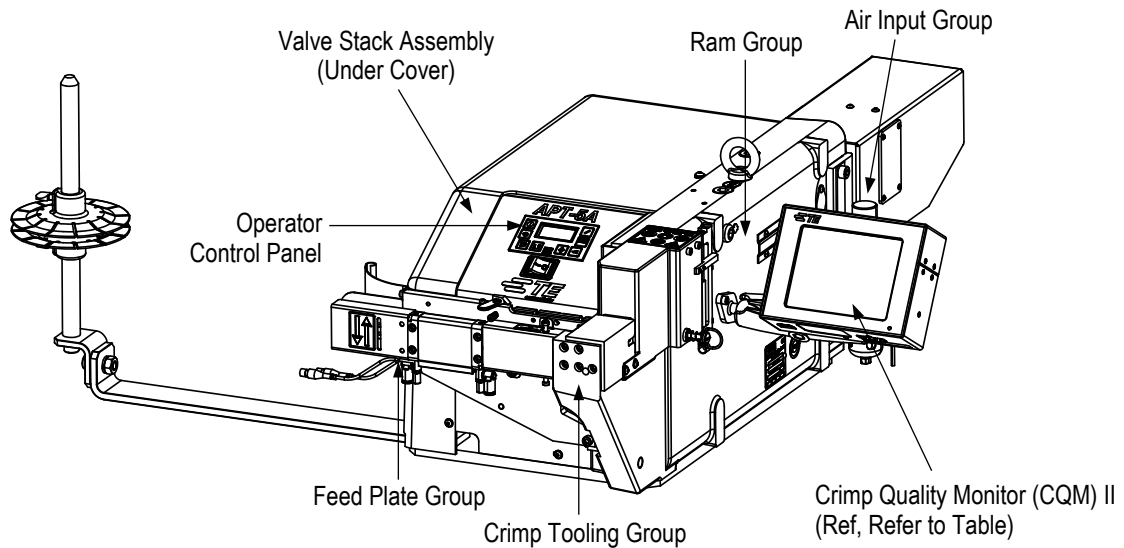

AMPLIVAR PRODUCT TERMINATOR

Type	Model	Part Number	Description
Splice	APT-5E (Economy)	2161900-[]	Has precision manual crimp height adjustment.
	APT-5A (Automatic)	2161800-[]	Used with CQM II and has automatic crimp height adjustment and automatic sequencing.
	APT-5E HF (Economy High Force)	2217700-[]	Has precision manual crimp height adjustment with high force capacity.
	APT-5A HF (Automatic High Force)	2217600-[]	Used with CQM II and has automatic crimp height adjustment and automatic sequencing with high force capacity.
Direct Connect	APT-5E DC (Economy)	2161950-[]	Has precision manual crimp height adjustment.
	APT-5A DC (Automatic)	2261850-[]	Used with CQM II and has automatic crimp height adjustment and automatic sequencing.
Infinite Splice	APT-5E Infinite Splice	2326145-[]	Equipped with Infinite Splice feature and has precision manual crimp height adjustment
	APT-5A Infinite Splice	2326135-[]	Equipped with Infinite Splice feature and CQM II and has automatic crimp height adjustment and automatic sequencing

Note: Refer to 409-10100 for information for the CQM II.

Figure 1

1. INTRODUCTION

This manual provides information concerning the setup, operation, and maintenance of the AMPLIVAR product terminator shown in Figure 1. Terminator variations are given in Figure 1. These terminators apply AMPLIVAR pigtail splices and AMPLIVAR cluster receptacles to pre-stripped wires and unstripped magnet wire.



NOTE

Dimensions in this manual are in metric units [with U.S. customary equivalents in brackets] unless otherwise indicated.

Serrations in the splices cut through the magnet wire insulation to make electrical contact. This eliminates a time-consuming stripping operation. Splices are applied with uniformly high mechanical strength and electrical conductivity at high-volume production pin rates.

Each AMPLIVAR product terminator weighs approximately 71 kg [156 lbs] and requires a power source of 100 to 240 Vac, 50/60 Hz 3 A, single phase, depending on the model of the terminator. Compressed air at a minimum pressure of 620.5 to 689.5 kPa [90 to 100 psi] for standard (E, A, and DC) terminators and 760 to 830 kPa [110 to 120 psi] for high force (HF) terminators is required for proper operation.

Optional wire stuffer assembly 2161635-1 can be used with this terminator to eliminate the need to change AMPLIVAR splices if the combined circular mil area (CMA) of the wires to be crimped is less than the specified minimum of the splice used. **Note:** This device is used when the customer CMA is less than the minimum published CMA for the AMPLIVAR product being terminated. The wire stuffer provides additional magnet wire CMA to the terminated CMA to meet the specified CMA range for a given AMPLIVAR product.

**NOTE**

An air amplifier may be required if the available compressed air supply does not meet the minimum requirements. Refer to Paragraph 2.1 D.

**NOTE**

The Infinite Splice assembly cannot be used at the same time as the wire stuffer assembly. The user must choose one assembly per application.

When reading this manual, pay particular attention to DANGER, CAUTION, and NOTE statements.

**DANGER**

Denotes an imminent hazard that may result in moderate or severe injury.

**CAUTION**

Denotes a condition that may result in product or equipment damage.

**NOTE**

Highlights special or important information.

For information beyond the scope of this manual, contact the Tooling Assistance Center at the number at the bottom of page 1.

**NOTE**

Dimensions in this customer manual are in metric units [with U.S. customary units in brackets]. Figures are not drawn to scale.

2. DESCRIPTION

AMPLIVAR product terminators automatically feed terminals into position in the crimping area, crimp the terminals to magnet wire, and trim the scrap wire from the terminals. Unlike many standard bench-type crimping machines, the primary crimping motions on the terminator occurs in the horizontal plane, and not vertically, as in many other TE automatic machines.

The crimp tooling is nearly flush with the right-hand surface of the terminator, allowing the operator to hold the wire close to the tooling for splicing very short leads.

During production operation, the operator places magnet wire and lead wire in the barrel of the terminal in the "target area" of the terminator, then depresses the foot switch. The terminator automatically shears the terminal from its strip, crimps the terminal onto the wire, shears off the excess wire, and advances the next terminal into the crimping position. The terminator electrical circuit prevents double-tripping; that is, the foot switch cannot be actuated when a cycle is in progress. The amount of time the foot switch is depressed is not critical.

The large number of wire combinations that can be joined with the splices requires some tooling changes, although design features minimize the number of changes required. Refer to drawing 216175 for tooling combinations. Only two different feed plates are required to terminate the entire range of splices. Two or three wires may be joined in one splice and combinations of magnet wire and lead wire (stranded, solid, or fused stranded) can be used.

**NOTE**

Magnet wire should always be placed on the bottom of the terminal wire barrel so that the serrations pierce the magnet wire varnish for an acceptable termination.

**NOTE**

CMA is the cross-sectional circular area of a magnet wire. For example, when terminating two .040-in. diameter magnet wires, each wire would have a CMA of 40 mils squared or 1600 CMA per wire for a total CMA of 3200. CMA for stranded wire is the diameter of a single strand in mils squared times the number of strands.

2.1. Major Groups

The four major terminator groups, or subassemblies, are: 1) the feed plate group, 2) the crimp tooling group, 3) the ram group, and 4) the air input and valve stack assembly. Refer to Figure 1.

A. Feed Plate Group

A.1. For Splice Terminators

Two feed plates are available to accommodate the full range of terminals. Each feed plate contains a groove that guides the terminal strip to the "target area." The feed finger, driven by the air feed cylinder, advances the terminal strip. Each cycle of the terminator advances the strip one position. The terminal strip drag prevents the strip from being pulled back as the feed finger retracts to pick up the next feed point in the strip. The hold down secures and controls the terminal strip through the feed plate (see Figure 2).

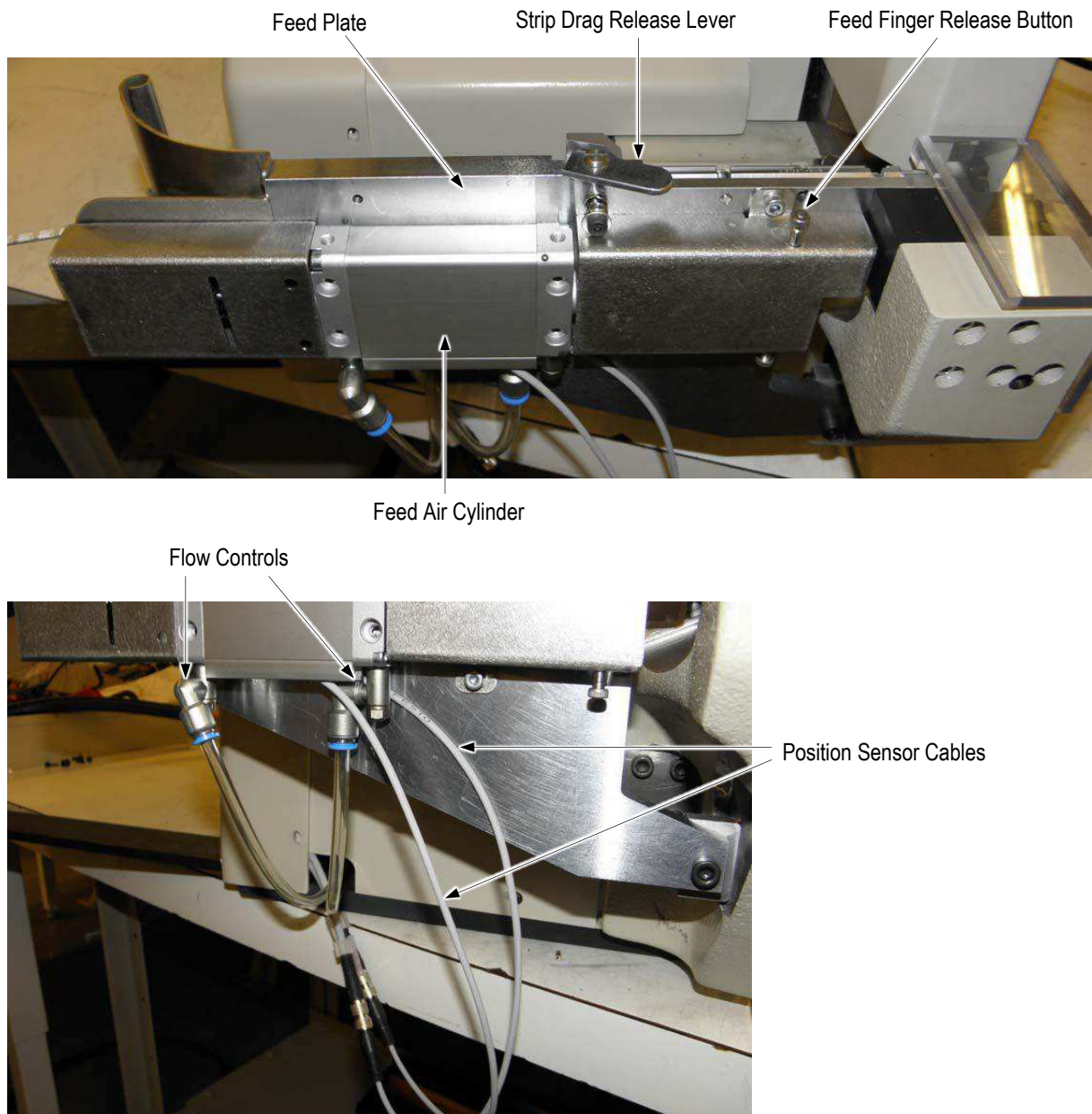

Figure 2

A.2. For Direct Connect Terminators

Two feed plates are available to accommodate the full range of terminals. Each feed plate contains a groove that guides the terminal strip to the "target area." The feed finger, driven by the air feed cylinder, advances the terminal strip. Each cycle of the terminator advances the strip one position. The terminal strip drag prevents the strip from being pulled back as the feed finger retracts to pick up the next feed point in the strip. The hold down secures and controls the terminal strip through the feed plate (see Figure 3).

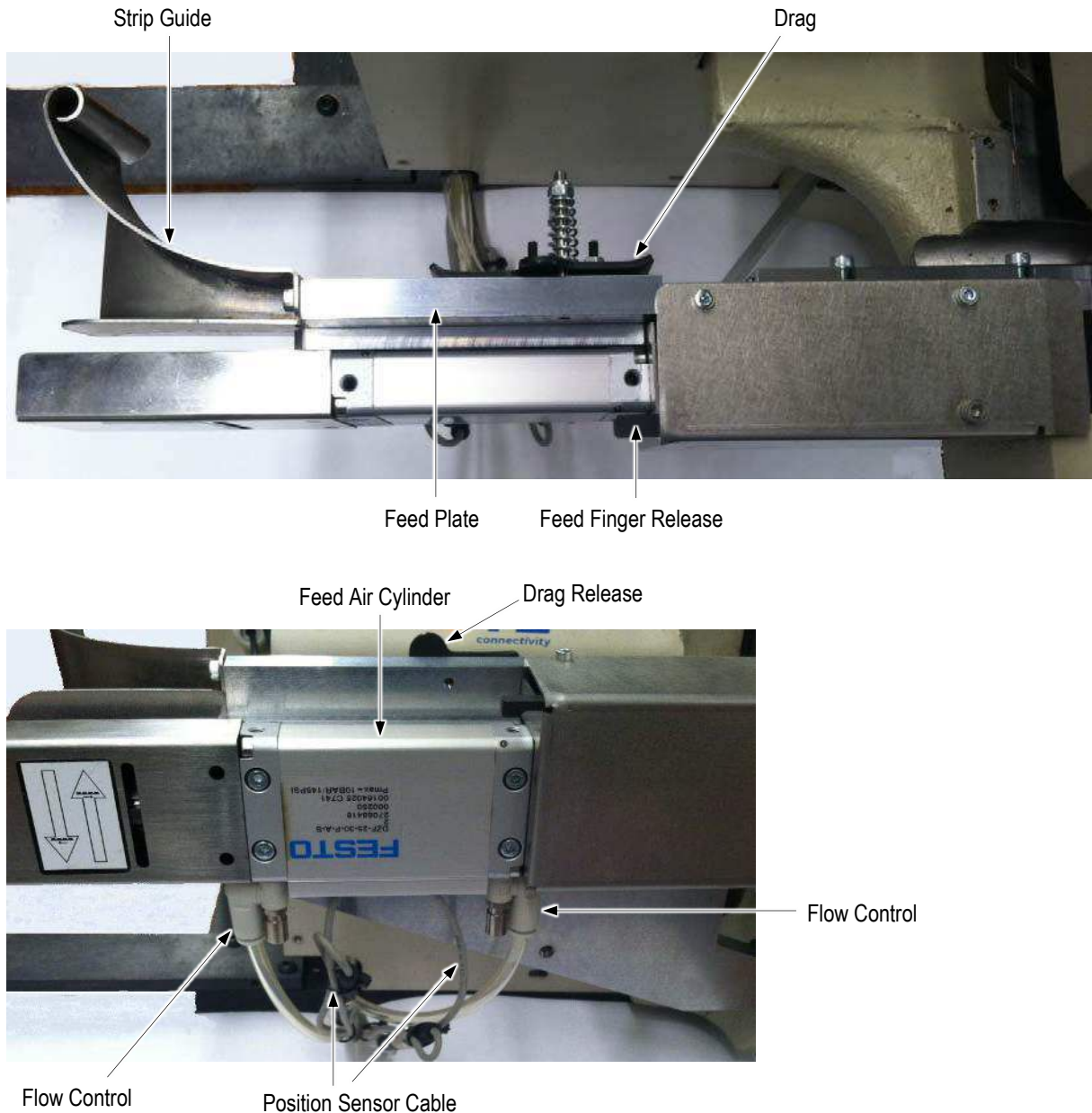

Figure 3

FESTO is a trademark.

B. Crimp Tooling Group

B.1. For Splice Terminators

The crimp tooling group for splice terminators consists of the crimper holder, the shear blade, and the crimper. **Note:** For machines with Infinite Splice, see Section 11.

The crimper holder is attached to the ram with two screws. The crimper and the shear blade are attached to the crimper holder with two screws. The sides opposite the crimping and shear surfaces must be seated against the crimper holder. The anvil holder is mounted to the terminator frame. The anvil is held in place in the anvil holder by the stripper guide plate. The guide shear is mounted on the anvil holder and helps ensure that the wire is positioned for a perfect crimp. The crimper guide is engaged with the anvil holder at all times and eliminates crimper-anvil adjustment in one direction (see Figure 4).

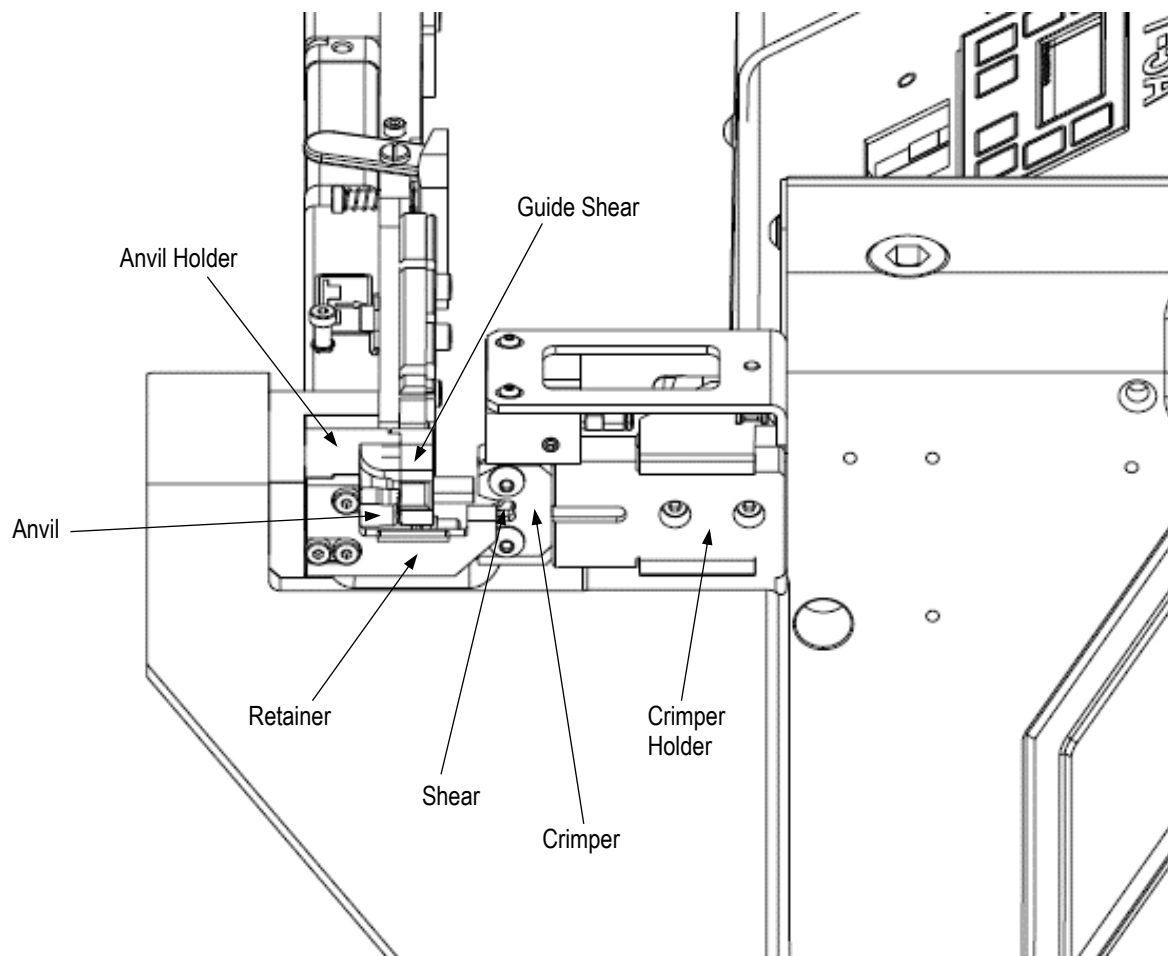

Figure 4

When the ram advances, the shear blade trims the scrap wire and at the same time shears the terminal from the strip. As the ram retracts, the stripper plate strips the crimped terminal from the crimper. As the ram reaches the fully retracted position, a preset blast of air is directed at the anvil to clear scrap wire and chips from the "target area." When the ram is fully retracted, the feed finger extends and the cycle is complete.

B.2. For Direct Connect Terminators

The crimp tooling group for direct connect terminators consists of the insulation and wire crimper with insulation disc and spacer attached to the ram with a button head screw. The slug blade is attached to the ram with two socket head cap screws. The wire anvil and insulation anvil lock into the anvil holder with the retainer plate. The product guide attaches to the anvil holder with two, socket head cap screws. The wire shear attaches to the product guide with two socket head cap screws. The product hold down attaches to the feed plate with two button head screws. The anvil holder attaches to the frame with three socket head cap screws (see Figure 5).

When the ram advances, the slug blade pre-trims the wire with the product hold down and the wire shear. The wire crimper and product guide then perform a final wire trim, and the slug blade and front shear cut the connecting carrier from the terminal strip. The feed finger retracts to pick up another terminal.

Product is crimped when the ram is fully extended. The ram retracts and a preset blast of air is directed at the anvil to clear scrap wire and chips from the “target area.” With the ram fully retracted, the feed finger feeds a terminal into position for crimping and the cycle is complete.

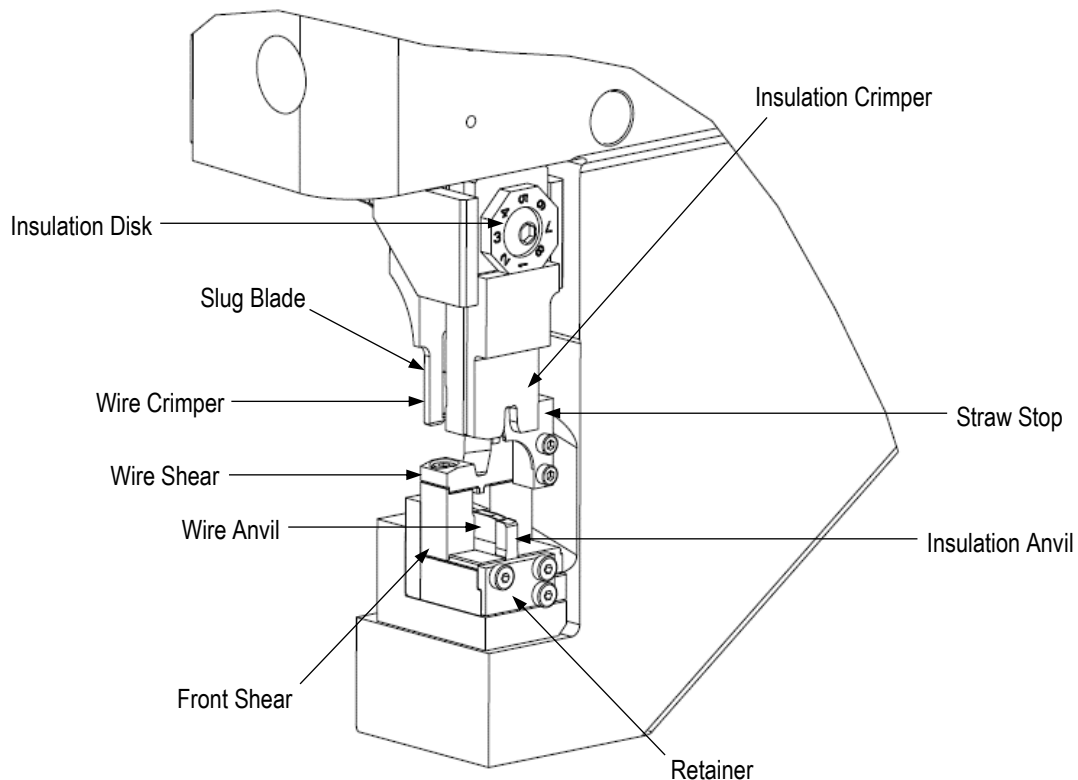

Figure 5

C. Ram Group

The ram group provides the force required for the crimper to crimp terminals. The ram group consists of the terminator frame, ram air cylinder, link, ram bell crank, and the ram. When the ram air cylinder is fully retracted, the ram is also fully retracted by the linkage which connects the two components (see Figure 6).

Refer to Paragraph 4.3.C. for further details on checking the ram stroke.



Figure 6

D. Air Input and Valve Stack Assembly

Compressed air supplied to the terminator passes through air filters to provide clean air for the air valves and air cylinders (see Figure 7).

The main components of this system are the lockout valve, air filter, coalescing filter, main solenoid valve, regulator, gage, and manifold assembly. Refer to the pneumatic diagram in Figure 8 for a functional description of the valve operation in relation to the air cylinders.



Air Input, Filter, and Regulator

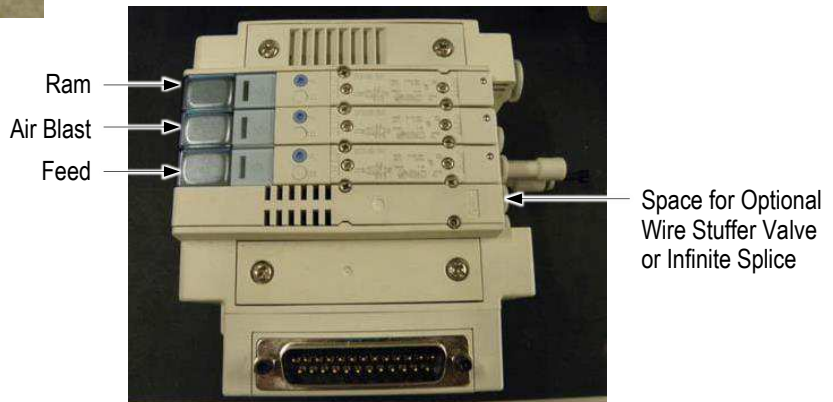
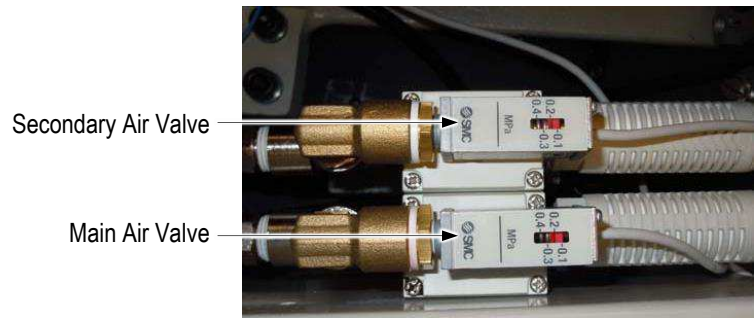

Figure 7

Pneumatic Diagram

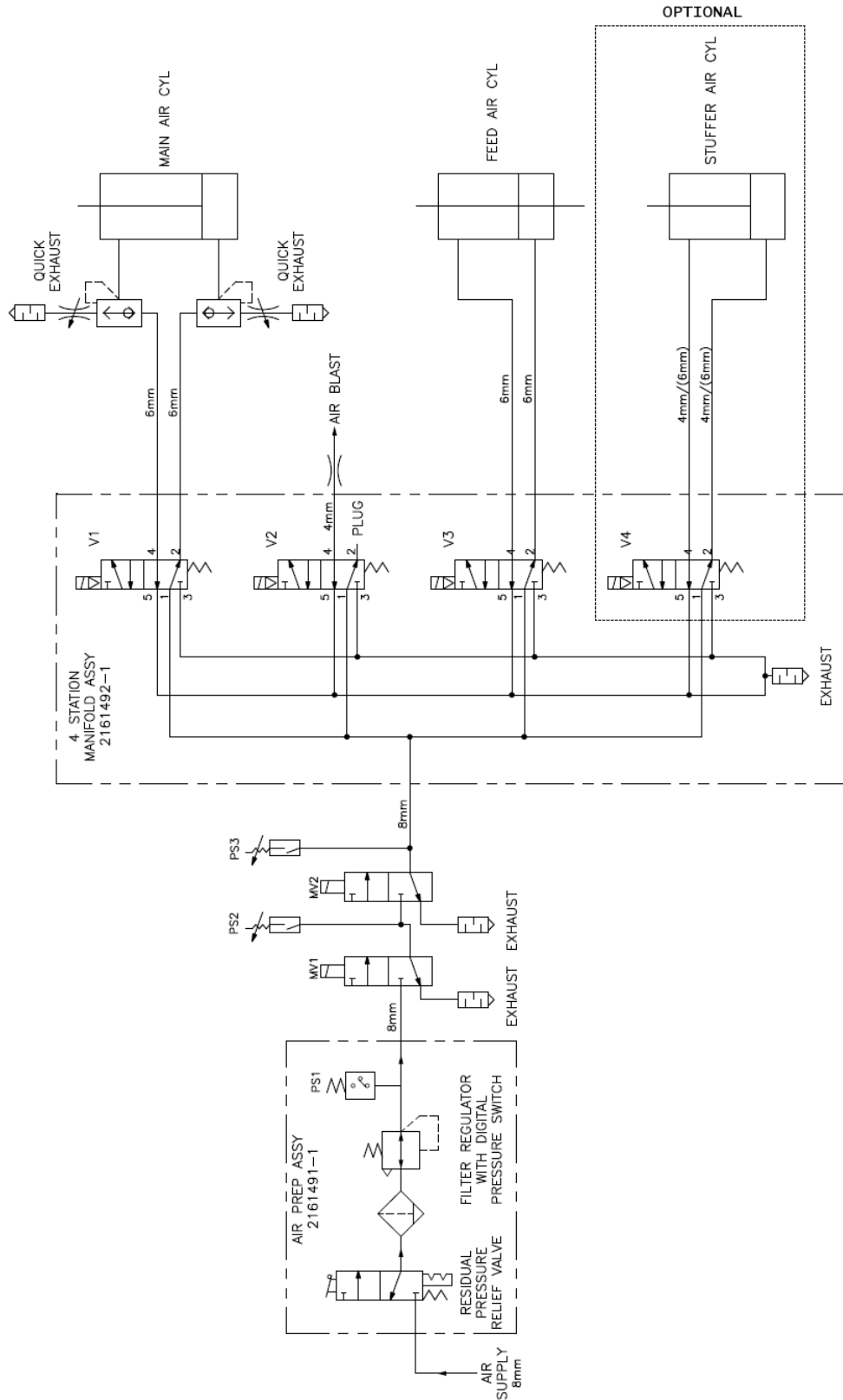

Figure 8

2.2. Switches and Controls

The operator control panel, located at the front of the terminator, contains all the switches and controls necessary for operation (see Figure 1).

A. Normal Key Functions

See Figure 9.

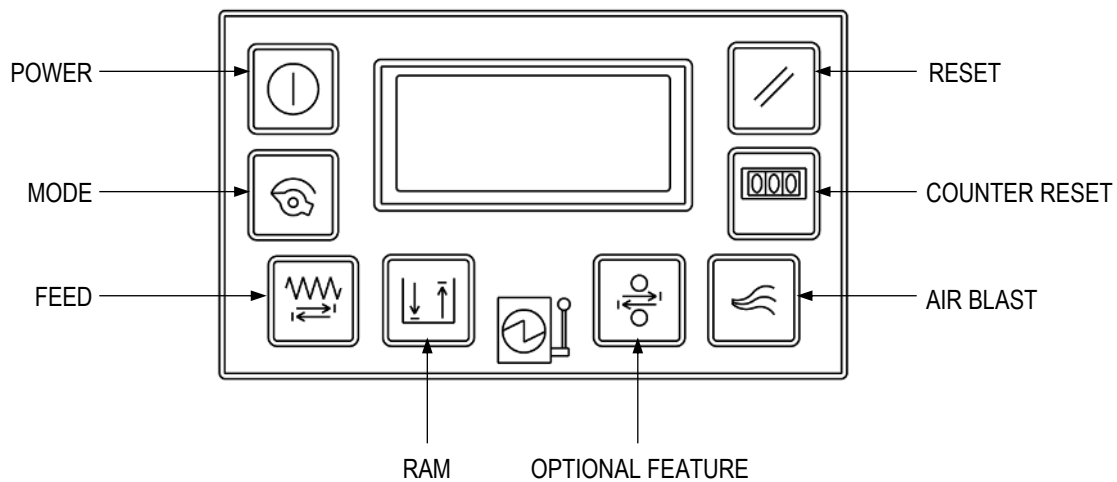

KEY	FUNCTION
POWER	Turns power "on" and "off." POWER off dumps the main air supply and turns off the electric supply. Note that the air supply must be available (LOCKOUT ON) to turn the power on.
MODE	Sequences the terminator through possible conditions of operation. The terminator is in the RUN mode when first powered on. <ul style="list-style-type: none"> — RUN mode is used to cycle the terminator automatically. — MANUAL mode is used to perform selected tooling moves. The keypad is used to cycle the terminator in the MANUAL mode.
FEED	Feeds product to the crimp tooling. It can be used only in the RUN or MANUAL modes.
RAM	Cycles the crimping ram. It can be used in the MANUAL mode only.
OPTIONAL FEATURE	For use with optional Wire Stuffer or Infinite Splice feature. It can be used in the MANUAL mode only.
AIR BLAST	Cycles the air blast to the "target area." It can be used in the RUN or MANUAL mode.
ERROR RESET	Resets the terminator after errors.
COUNT RESET	Resets the current crimp cycle count.

Figure 9

B. Special Key Functions

The functions listed in Figure 10 are performed with the power on and can be performed with guards open.



DANGER

Be sure to keep clear of moving equipment while these functions are performed.

KEY	FUNCTION AND DESCRIPTION
FEED MODE	<p>Each application requires a distinct feed mode: Normal APT: Post-Feed Extend HF APT: Post-Feed Retract Wire Stuffer: Pre-Feed Extend</p> <p>To toggle between modes, proceed as follows:</p> <ol style="list-style-type: none"> 1. Press and hold MODE key. 2. Press and hold FEED key. 3. Release MODE key 4. Release FEED key (the current state is briefly displayed when FEED key is released).
AIR BLAST TIME MODE and ADJUSTMENT MODE	<p>To enter the mode whereby the air blast time (duration) can be adjusted, proceed as follows:</p> <ol style="list-style-type: none"> 1. Press and hold MODE key. 2. Press and hold AIR BLAST key. 3. Release MODE key. 4. Release AIR BLAST key. <p>The message “Air Blast Time xxx ms” will be displayed. The minimum time is 0 milliseconds. The maximum time is 1000 milliseconds. Adjust the air blast as follows:</p> <ul style="list-style-type: none"> — Press FEED key to decrease the air blast time by 5 milliseconds. — Press RAM key to increase the air blast time by 5 milliseconds. — Press COUNT RESET key or the WIRE STUFFER key to increase the air blast by 100 milliseconds. — Press RESET to decrease the air blast time by 100 milliseconds. <ol style="list-style-type: none"> 5. Press MODE key to exit the AIR BLAST TIME ADJUSTMENT MODE.

Figure 10

C. Foot Switch

Depressing the foot switch enables the terminator to complete one cycle of operation. The terminator cannot be cycled again until the foot switch is released. Once a cycle is in progress, it must be completed before another cycle can occur.

2.3. Functional Description

For a description of the terminator pneumatic functions, refer to Pneumatic Diagram

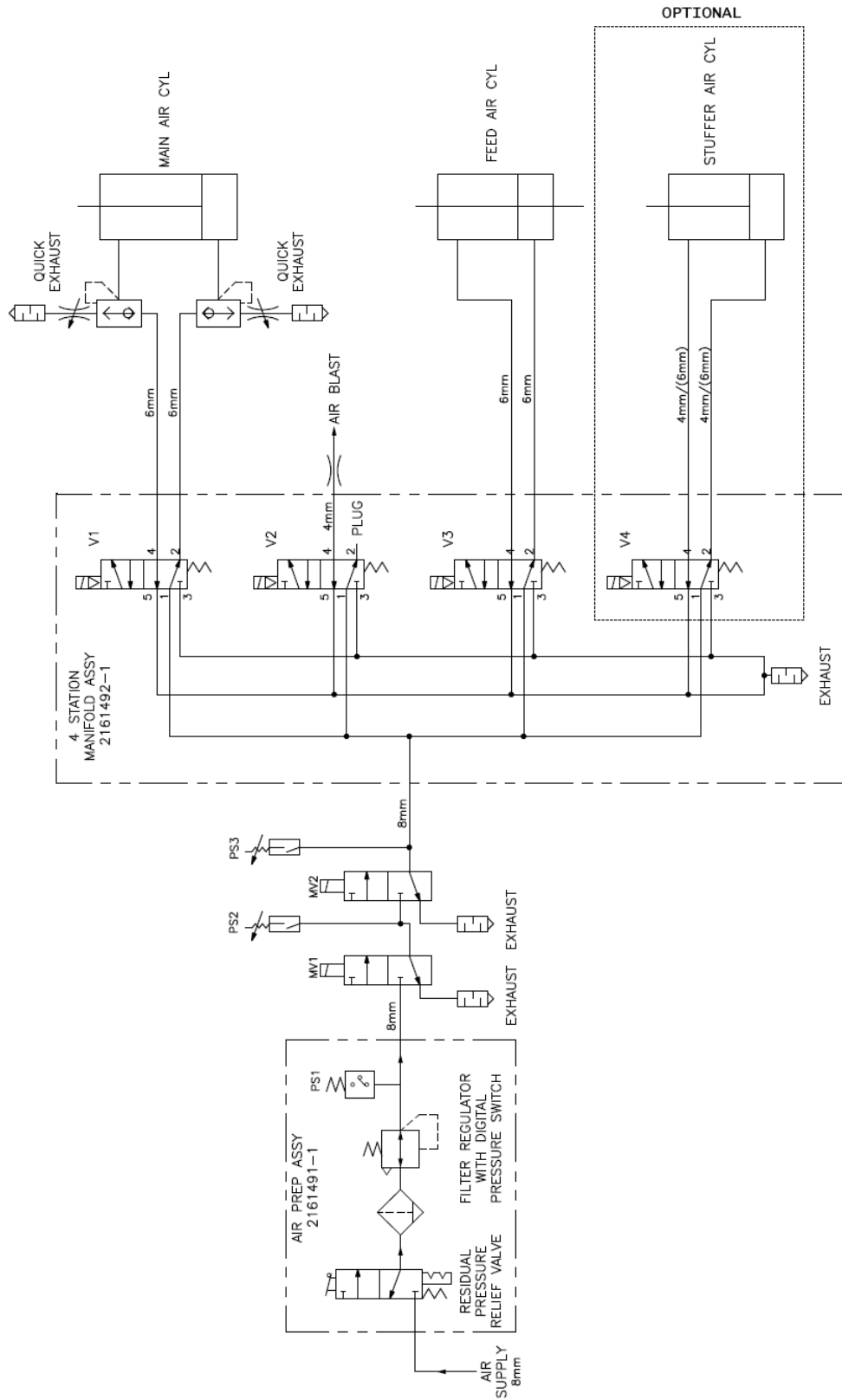

Figure 8 (pneumatic diagram) and the pneumatic drawings shipped with the terminator.

3. RECEIVING INSPECTION AND INSTALLATION

3.1. Receiving Inspection

The terminator is thoroughly inspected during and after assembly. Prior to packaging and shipping, a final series of tests and inspections is made to ensure proper functioning of the terminator. Although the terminator should require no adjustments before placing it into operation, the following inspection should be performed as a safeguard against potential problems generated in transit.

1. Carefully uncrate the terminator, and place it on a sturdy bench or table with proper light to permit a careful examination.
2. Thoroughly inspect the entire terminator for evidence of damage that may have occurred in transit. If it is damaged in any way, file a claim against the carrier and notify TE immediately.
3. Check all components to be certain that they are secure.
4. Check all wiring for loose connections, cuts, or other possible causes of electrical short circuits.
5. Inspect all pneumatic lines for evidence of loose connections and cuts that may cause leakage.

**NOTE**

It is important that this manual and other documents (such as drawings and parts lists), as well as any enclosed product samples, remain with the terminator for the benefit of personnel responsible for installation, operation, and maintenance.

3.2. Considerations Affecting Terminator Placement

The location of the terminator in relation to the operator is essential to both safety and efficiency. Studies have repeatedly shown that fatigue will be reduced and efficiency increased if particular attention is paid to the bench, the operator's chair, and the placement of the foot switch (if used).

**NOTE**

If the terminator is mounted to base 2161367-1, make sure to bolt the terminator base to the table.

A. Bench

A sturdy bench, 711 to 762 mm [28 to 30 in.] high, aids comfort by allowing the operator's feet to rest on the floor. The operator's weight and leg position can be easily shifted. The bench should have rubber mounts to reduce noise. The open area under the bench should allow the chair to slide in far enough for the operator's back to be straight and supported by the back rest.

B. Terminator Location on Bench

The terminator should be located near the front of the bench and the tooling area (the area where product is applied) should be 152 to 203 mm [6 to 8 in.] from the front edge. Access to the back of the terminator must be provided.

C. Operator's Chair

The operator's chair should swivel, and the seat and back rest should be padded and independently adjustable. The back rest should be large enough to support the back both above and below the waist.

In use, the chair should be far enough under the bench so that the operator's back is straight and supported by the back rest.

D. Foot Switch

When the operator is correctly positioned in front of the terminator, the foot should rest on the switch comfortably and easily. The operator's back must be straight and supported by the chair and the upper arms in direct line with the torso. The switch should be placed on a rubber mat. This allows the switch to be movable and permits the operator to shift positions to minimize fatigue. At the same time the mat prevents the switch from sliding unintentionally.

The preference for locating the switch varies among operators. Some like the switch located so that their foot rests on the switch when their legs are in the natural sitting position (calf perpendicular to the floor). Others prefer it slightly in front of the natural position. It is important that the foot be approximately 90 degrees to the calf when resting on the switch. Those who prefer the switch slightly forward may require a wedge-shaped block placed under it.

Figure 11 shows typical layout for the efficient handling of materials.

3.3. Installation

The terminator can be used in several different configurations, with and without the CQM II. Refer to customer manual [409-10100](#) for installation instructions.

Typical Plan View to Illustrate Convenience of Handling Materials Afforded by Proper Setup

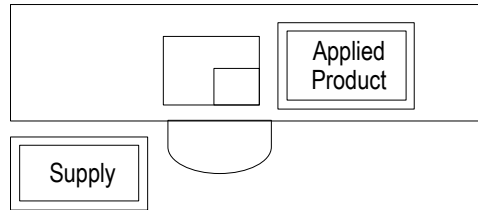

Figure 11

4. SETUP

This section contains procedures for setting up the terminator and checking it out prior to performing production operation. Proper terminator setup will assure that all alignments and adjustments are correct in order to produce terminations of the proper crimp height for the type of terminal and size wire being used. If procedures are not carried out in detail, especially following the initial installation of the terminator, damage may result to the tooling. Also included in this section is the manual cycling procedure. Note that this procedure is referenced throughout this manual.

4.1. Pre-Loading Alignment Check



CAUTION

DO NOT perform this procedure except when specified within another procedure, and then only in the proper sequence. Otherwise, damage to the tooling may result due to misalignment and/or wrong adjustments.

1. Before connecting the air or electric, completely close the air regulator by turning the regulator knob *counterclockwise* until it is snug.
2. Connect the electrical plug and air supply to the terminator.
3. Depress the power key (shown in Figure 9).



DANGER

To avoid personal injury, keep hands clear of the feed plate and the "target area" at all times.

4. Depress the mode key.
5. Press the ram key, then slowly open the regulator by turning the knob *clockwise*. This will allow the ram to advance slowly.
6. Closely observe the shear and crimper assembly as it nears the anvil. If the shear and crimper assembly are not aligned, immediately close the regulator by turning the knob *counterclockwise*. Make any necessary adjustments before proceeding.
7. After the ram has fully extended, open the regulator knob (turn *clockwise*) until the gage reads 621 kPa [90 psi]. The ram will remain fully extended under pressure.
8. Press the ram key again to retract the ram.
9. Depress the feed key.
10. Depress the mode key to enter the run mode.
11. Depress the power key, then disconnect the electrical plug and air supply.

4.2. Tooling Alignment Procedure

This procedure is necessary when replacing anvil holders or any time the screws securing the anvil holders are loosened (see Figure 17).



DANGER

To avoid personal injury, be sure the electrical and air supply are disconnected before starting this procedure. Accidentally cycling the terminator could result in personal injury.

1. Open the guards.
2. Remove the three screws securing the anvil holder to the frame.
3. Remove retainer from the anvil holder, and remove the anvil; then slide new anvil holder over the crimper guide, and loosely install the three screws to the anvil holder.
4. Install the anvil and retainer (for direct connect terminators, install both anvils). *For direct connect terminators only*, move the anvil holder until the product guide is against the slug blade.
5. Place one thickness of paper over the anvil(s), and center the anvil below the crimper.
6. Slowly advance the ram by performing the pre-loading alignment check described in 4.1.
7. Tighten the screws securing the anvil holder to the frame, and tighten the screws in the retainer to secure the retainer to the anvil holder.
8. Close the guards on the terminator
9. Retract the ram by pre-loading alignment check described in Paragraph 4.1.

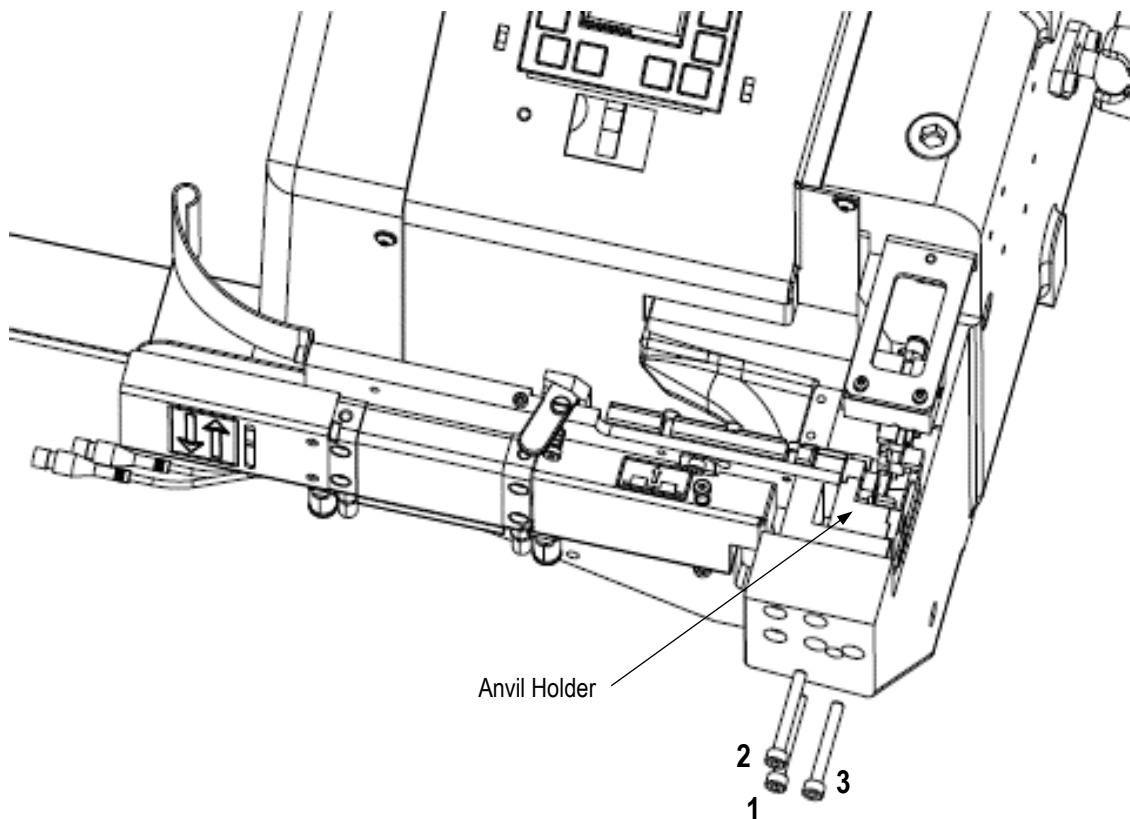

Tighten Screws in Numerical Order

Figure 12

4.3. Terminal Strip Loading

A. For Splice Terminator

**DANGER**

To avoid personal injury, be sure the electrical plug and air supply are disconnected. Accidentally cycling the terminator could cause personal injury.

1. Place a reel of the correct type of terminals on the reel support so the terminal strip enters the groove in back of the feed plate with the open "U" toward the back of the terminator.
2. Rotate the drag lever to release and hold the drag open (back), then feed the terminal strip through the strip guide and groove in the feed plate until the end reaches the feed finger (see Figure 13).
3. Depress and hold the feed finger release button on front of the feed plate while feeding the terminal strip through until the first terminal has passed the tip of feed finger. Then release the button to engage the feed finger. Pull back slightly on the terminal strip to ensure that the feed finger is indexed against the first terminal (refer to Figure 14).

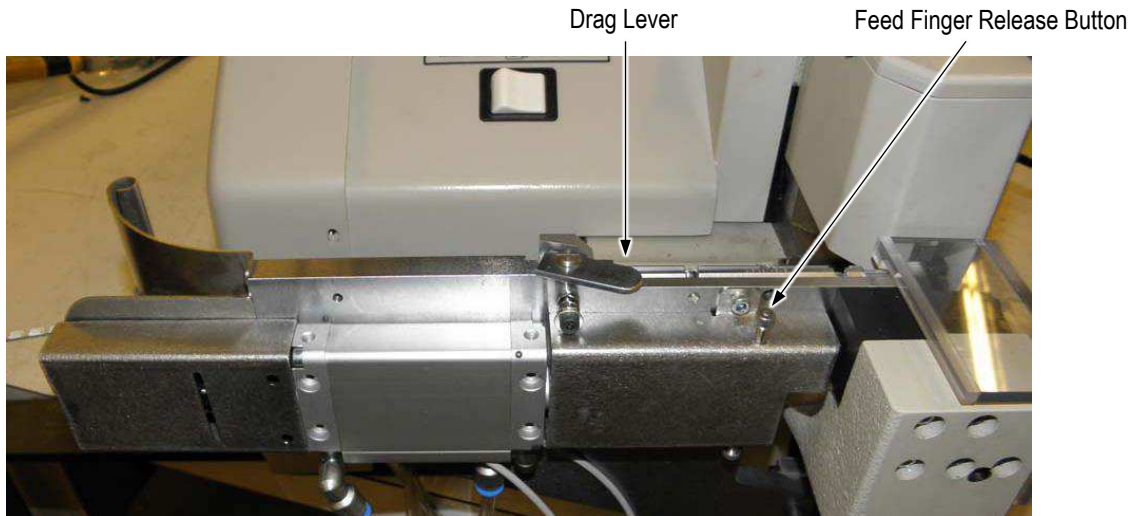

Figure 13

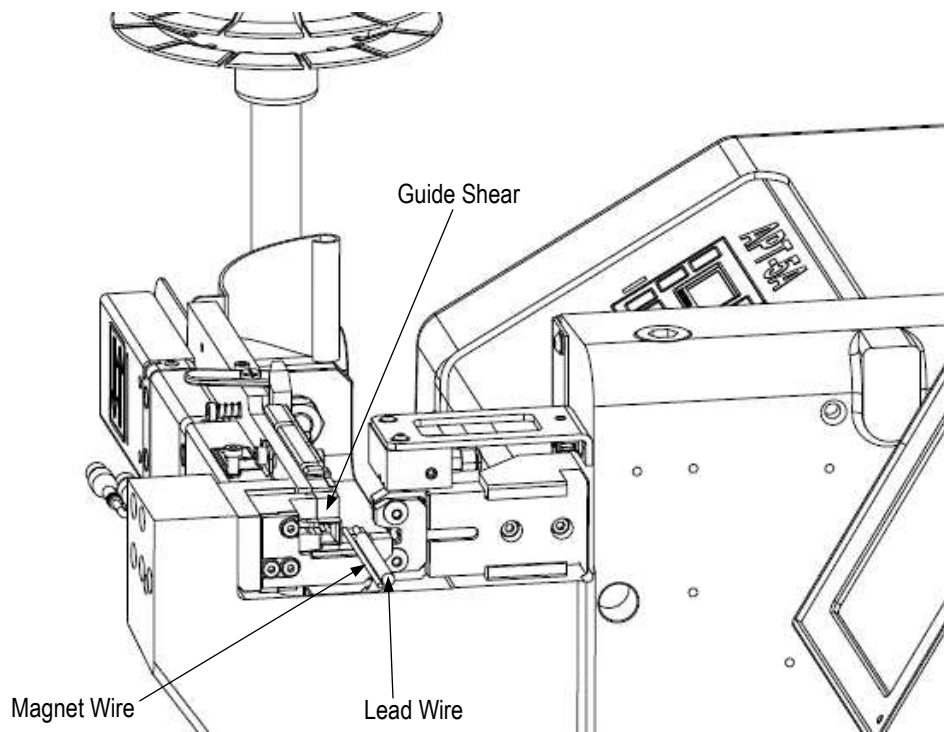

Figure 14

B. For Direct Connect Terminator



DANGER

To avoid personal injury, be sure the electrical plug and air supply are disconnected. Accidentally cycling the terminator could cause personal injury.

1. Place a reel of the correct type of terminals on the reel support so the terminal strip enters the groove in back of the feed plate with the open "U" toward the back of the terminator.
2. Lift the drag plate to release and hold the drag open, then feed the terminal strip through the strip guide and groove in the feed plate until the end reaches the feed finger (shown in Figure 3).
3. Feed the terminal strip through until the first terminal has passed the tip of feed finger and is over the lower tooling (anvil). Then, pull back slightly on the terminal strip to ensure that the feed finger is indexed against the first terminal. Refer to Figure 15.

Direct Connect Terminator

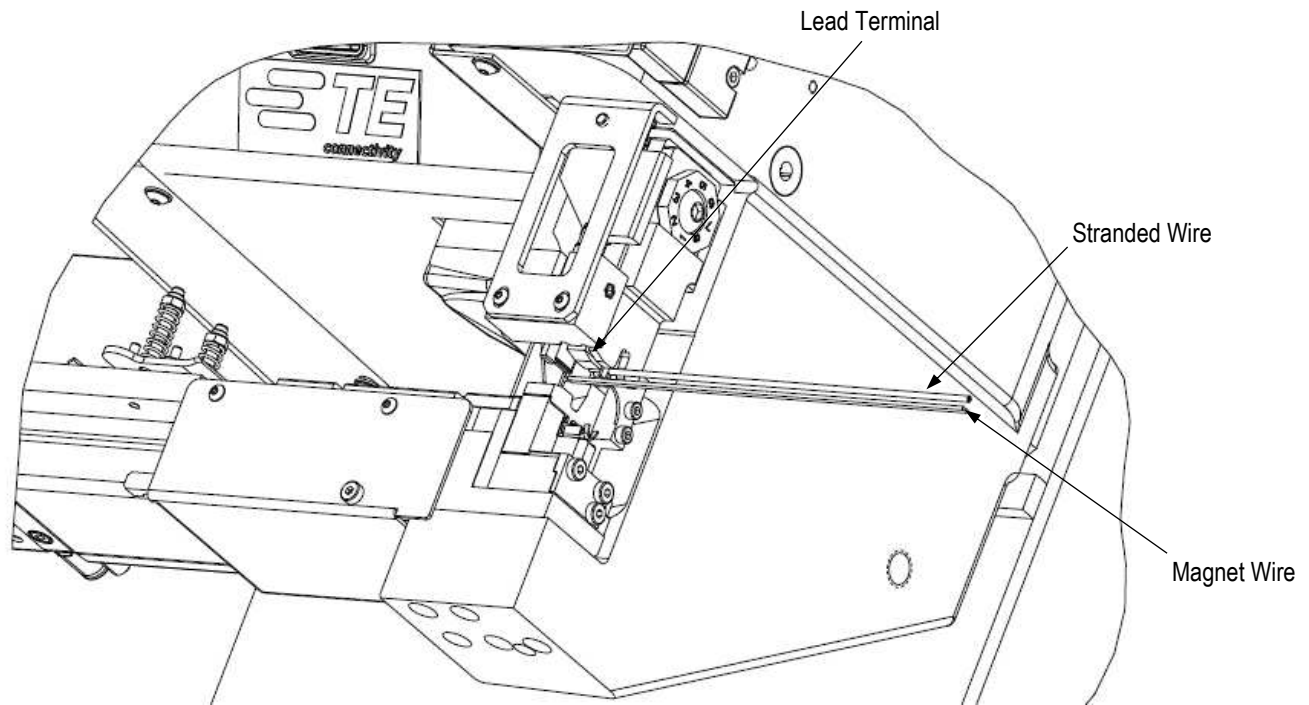

Figure 15

4.4. Terminator Checkout

A. Terminal Strip Feed Check

With the terminal strip loaded into the terminator as described in Paragraph 4.3, disengage and hold the feed finger while checking the drag on the terminal strip. The drag must be adjusted so that it applies enough pressure to prevent pull-back of the strip by the feed finger. If adjustment is required, refer to Paragraph 6.2. After checking the drag, re-position the first terminal as described in Paragraph 4.3.

Perform the following procedure in the manual mode:

1. Connect the electrical plug and air supply.
2. Toggle the on/off switch to on (located on the operator control panel just below the normal keys).
3. Depress the power key.
4. Depress and release the feed key. The terminal strip should advance one terminal length. Continue to depress and release the feed key until the first terminal is centered on the anvil. If the terminal *does not* stop directly centered on the anvil, adjust the feed as described in Paragraph 6.2.
5. At completion of this check, perform the ram cylinder/ram linkage check as described in Paragraph 4.4.0.

B. Ram Cylinder/Ram Linkage and Switch Check

1. Remove the terminator cover by removing the screws and washers.



DANGER

To avoid personal injury, keep hands clear of the terminator interior while performing this check.

2. Connect the electrical plug and air supply. Depress the power key on to assure the retraction side of the ram cylinder is pressurized.
3. Check the ram rest switch on the ram cylinder to be sure it is actuated closed. If necessary, adjust the switch as described in Paragraph 6.3.B.
4. Enter the manual mode by depressing the mode key.
5. Press the ram key to extend the ram cylinder.
6. Check the ram extended switch on the ram cylinder. If necessary, adjust the switch as described in Paragraph 6.3.A.
7. Re-install the terminator cover.
8. Perform the manual crimping check as described in Paragraph 4.4.C.

C. Manual Crimping Check

1. With the electrical plug and air supply connected, depress the power key.
2. With a terminal in the "target area," place the magnet wires or a combination of stranded wire and magnet wire in position with the magnet wire toward the front bottom of the terminal.
3. Manually cycle the terminator as described in Paragraph 4.1. Observe the ram advancement and the shearing and crimping of the terminal in the "target area."
4. After the ram has fully retracted, remove the terminal and inspect it in accordance with Paragraph 4.5. If necessary, make any adjustments that may be required.
5. At completion of this check, perform the automatic crimping check as described in Paragraph 4.4.D.

D. Automatic Crimping Check

The automatic crimping check is performed in the same manner as the manual crimping check described in Paragraph 4.4.C, except that the air regulator must be fully open. The terminator must be in the run mode and the foot switch must be depressed to cycle the terminator. Terminations must conform to the requirements given in Paragraph 4.5. If necessary, make any adjustments that may be required as described in Section 6.

If the terminations obtained from the manual crimping check and the automatic crimping check conform to all requirements, the terminator is ready for production operation as described in Section 5.

If the terminator is not to be operated immediately, depress the power key, then disconnect the electrical plug and air supply.

4.5. Termination Inspection

All terminations produced by the terminator must conform to quality and crimp height requirements as follows:

1. Inspect the termination for conformance to the requirements given in Figure 16, Detail A.
2. Using a crimp height micrometer, measure the crimp height of the termination as shown in Figure 16, Detail B. The crimp height must be within ± 0.08 mm [± 0.003 in.] of the measurement specified for the type of terminal and wire size being used.



NOTE

TE recommends the use of a modified micrometer. A typical micrometer is the Mitutoyo Series 342 micrometer. Refer to instruction sheet [408-7424](#) for crimp height information.

Mitutoyo is a trademark.

Detail A

ITEM	REQUIREMENT
1	This area of terminal must be bellmouth in shape.
2	The sheared end must be clearly cut off.
3	The wires must extend through the crimped terminal.
4	The magnet wire must lie in the bottom of the terminal.
5	When 2 magnet wires are seated, they must be side by side.

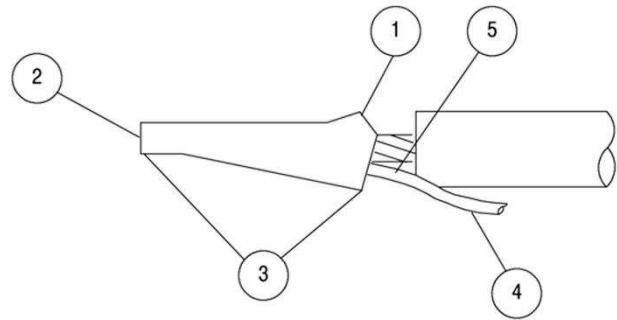

Detail B

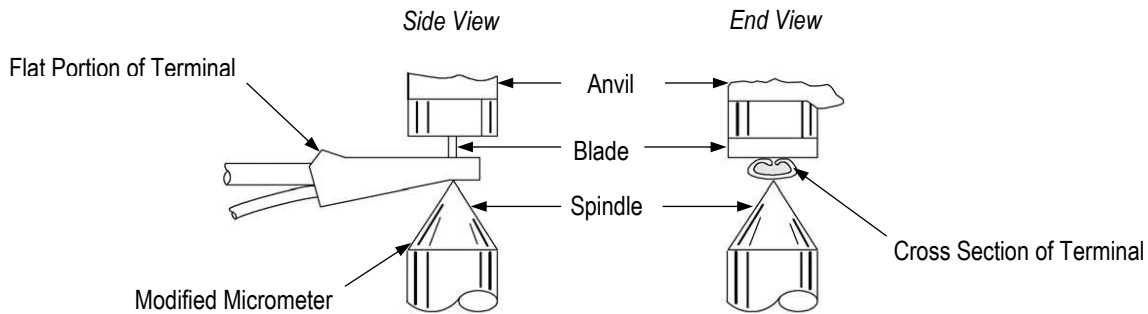

Figure 16

5. PRODUCTION OPERATION

Before placing the terminator in production operation, be sure it has been properly setup and checked out according to procedures in Section 4. Operate the terminator as follows.

1. Connect the terminator to the air supply.
2. Plug the electrical plug into the electrical outlet. Be sure all guards and covers are in place.



CAUTION

Never operate the terminator without a terminal over the anvil and wires in the "target area".

3. Depress the power key.



NOTE

Personnel who have not previously operated the terminator should manually cycle it several times, as described in Paragraph 4.1, while observing the operation and travel of the feed finger and ram before proceeding.

4. Place wires in the "target area," aligned with the terminal. When using stranded and magnet wire, position it as shown in Figure 14 (splice terminator) or Figure 15 (direct connect terminator). When splicing two or three magnet wires, they may be in any position with respect to each other. The crimp tooling will automatically position them side-by-side in the bottom of the terminal as crimping occurs.
5. With wires in position, depress the foot switch. The terminator will cycle only once regardless of how long the foot switch is held down.



NOTE

At periodic intervals during production operation, perform the termination inspection described in Paragraph 4.5.

6. At completion of the production operation, depress the power key. Disconnect the electrical plug and air supply.

6. ADJUSTMENTS

The following procedure may be necessary when adjusting the terminator, during production operation, or following the replacement of parts.

6.1. Crimp Height Adjustment (Tooling Increments)

Crimp height adjustment may be necessary to produce actual desired crimp height.

- Aligning the vertical line of the indicator plate with the radial thumb wheel groove and the horizontal line of the indicator plate with the axial thumb wheel zero groove will produce a maximum crimp height for all products (see Figure 17).
- Each vertical line on the indicator plate represents one thumb wheel revolution or a 0.406-mm [.016-in.] adjustment.
- To *decrease* the crimp height, turn the thumb wheel *clockwise*. To *increase* the crimp height, turn the thumb wheel *counterclockwise*. Note that these are tooling increments, which may not reflect the actual crimp height changes.

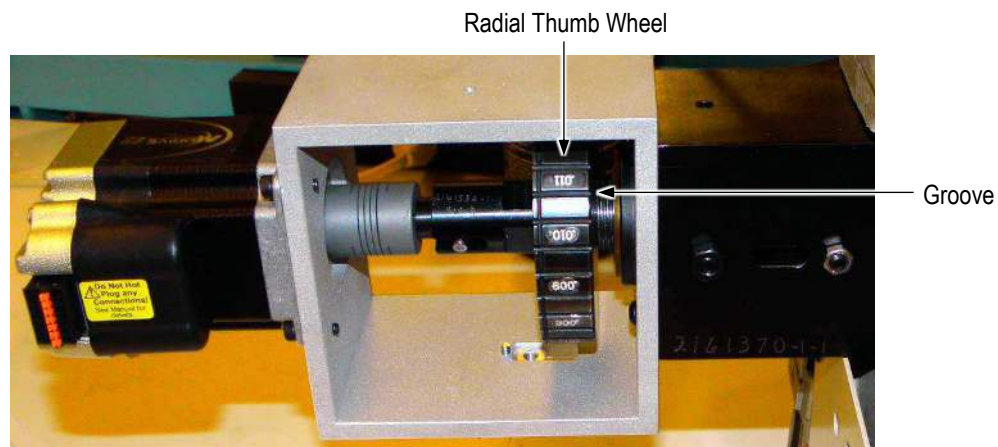

Figure 17

6.2. Feed Adjustments

A. For Splice Terminators



DANGER

To prevent personal injury when making adjustment, disconnect the power.



NOTE

For High Force applications, feed must be set to Post-Feed Retract (see Section 2.2.B.).

A.1. Feed Finger Engagement



NOTE

It is not necessary for the speed to be fast. Normally, the operator cannot remove a completed termination and insert wires for the next termination before another terminal is in position.

When replacing the feed finger (2161391) or when converting from one terminal part number to another, the feed finger engagement should be checked and adjusted if necessary. To set the feed finger engagement, perform the following steps.

1. Remove the feed guard (2161526-1).
2. Load the terminal strip until it just reaches the feed finger. DO NOT load the terminal strip beyond the feed finger (see Figure 18).
3. Adjust the torque locking hex nut (986965-7) until the feed finger is adjusted (see Figure 18).

4. Push the terminal strip forward to ensure that the terminals “click” past the feed finger, and then pull back on the terminal strip to ensure that the feed finger engages the terminal strip firmly.
5. Re-install the feed guard.

For Splice Terminators

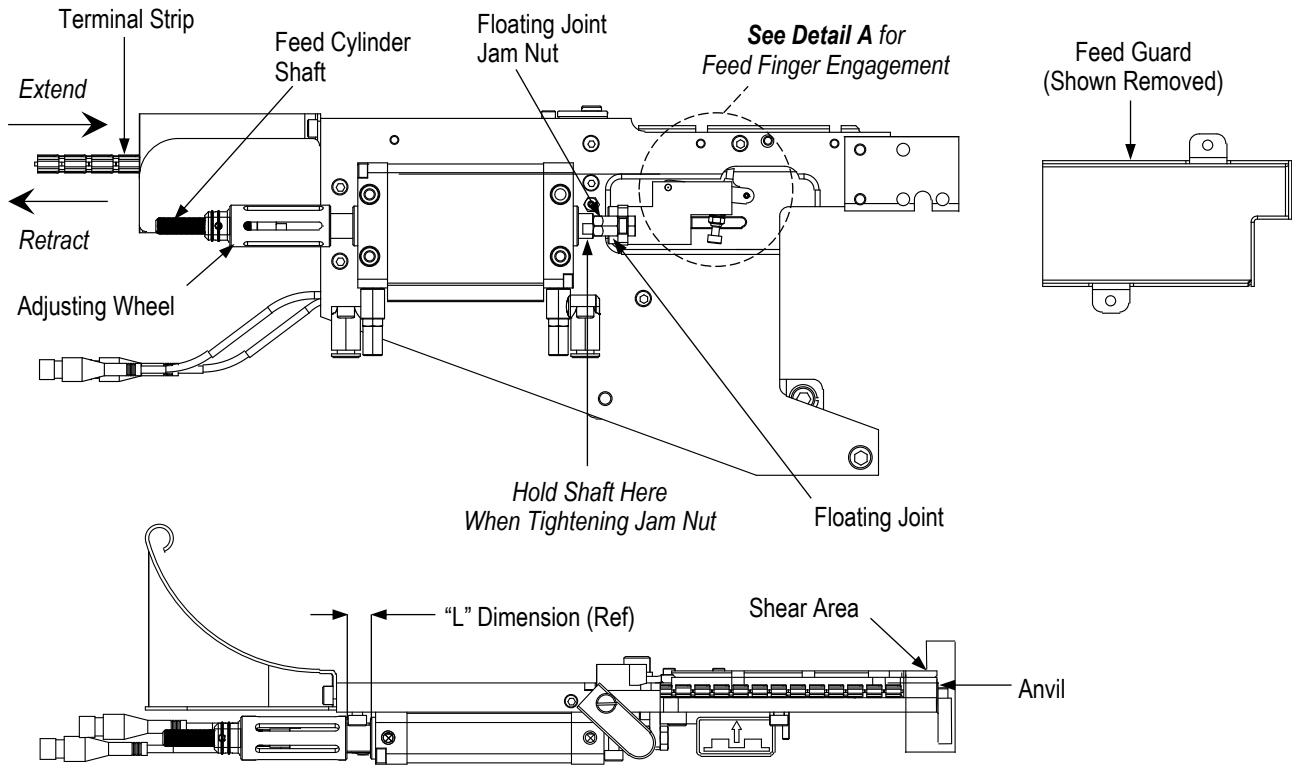

**DETAIL A
(FEED FINGER LIMITER)**

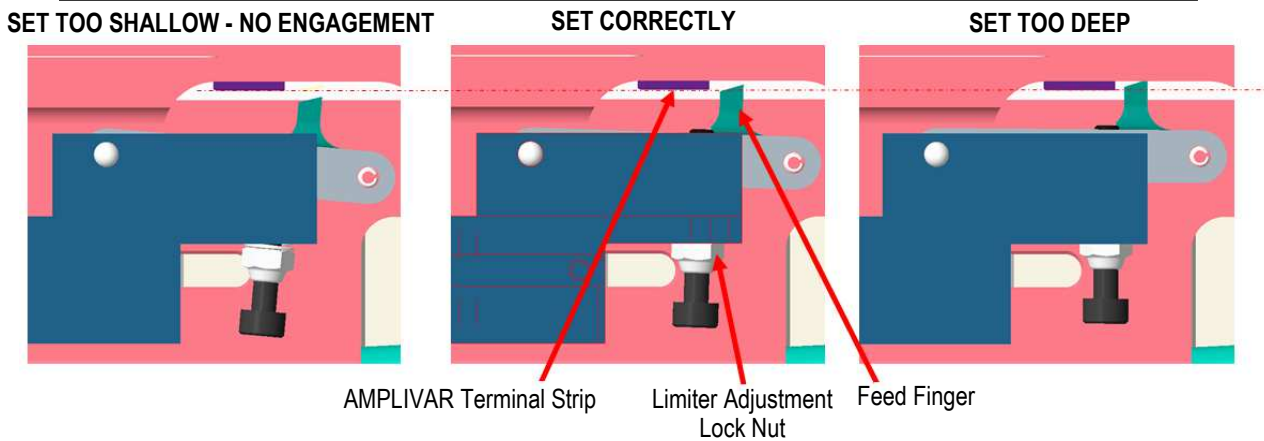

Figure 18

A.2. Flow Control Valves

The flow control valves located on the port fittings of the feed cylinder, should be adjusted in such manner as to slow the feed finger, advancement and retraction, and prevent it from slamming at the end of the stroke. This also helps prevent overfeeding.

To adjust the speed of the feed, turn the valve adjustment *in* to slow the cylinder action; turn it *out* for faster action.



NOTE

It is not necessary for the feed speed to be fast. Normally the operator cannot remove a completed termination and insert wires for the next termination before another terminal is in position.

A.3. Terminal Strip Drag

The drag must apply sufficient pressure to the terminal strip to prevent pullback of the strip by the feed finger when it is retracted to pick up the next feed point. If necessary, adjust as follows (see Figure 18):

1. Loosen the locknut on the drag setscrew. With the drag lever released, turn the setscrew as required until the drag rests evenly on the terminal strip.
2. While holding the setscrew in the adjusted position, tighten the locknut.
3. Rotate the drag lever to lift the drag from the terminal strip. The drag should pivot on the setscrew.

A.4. Initial Feed Stroke and Position Adjustment

1. Remove the feed guard (2161526-1).
2. Move the feed cylinder shaft to the fully retracted position.
3. Turn the adjusting wheel (2161481-1) to the appropriate "L" dimension for the terminal being processed (see Figure 18). Refer to drawing 2161490 for the "L" dimension for AMPLIVAR terminals.
If data is not available, set the "L" to the terminal pitch plus half of the gap between terminals (see Figure 19).

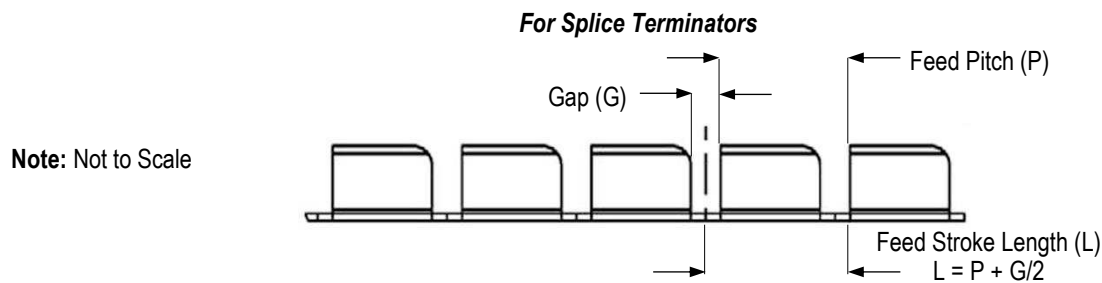

Figure 19

4. Load the terminal strip, and manually feed the strip by pushing the feed cylinder shaft to the full extend and full retract position until a terminal is located over the anvil.
5. Loosen the locknut (18029-3) on the floating joint (2168420).



NOTE

The cylinder shaft must be held using the wrench flats when tightening or loosening the jam nut or damage to the cylinder may occur.

6. Hold the feed cylinder shaft fully extended and adjust the floating joint until the terminal cutoff area aligns with the shear tooling.
7. Tighten the jam nut on the floating joint.
8. Install all guards.
9. Connect the electrical and pneumatic power to the terminator.

10. Perform several crimps, and measure the terminal cut-off.
11. If the cutoff tabs (front and back) of each terminal differ by more than 0.05 mm [.002 in.], disconnect the electrical and pneumatic power, remove the feed guard, and repeat steps 5 through 10 until the cutoff tabs differ by 0.05 mm [.002 in.] or less.
12. When the cutoff tabs differ by less than 0.05mm [.002 in.], perform a fine adjustment procedure.

A.5. Feed Position Fine Adjustment



NOTE

Terminal cutoff tabs may start to vary for several reasons, such as prolonged operation, tooling replacement, new terminal reel, or normal wear. If the cutoff tabs become uneven, a fine adjustment may be made using the adjustment wheel.

To make a fine adjustment, follow these steps:

1. Inspect a crimped terminal, and determine if the terminal strip needs more or less feed. If tab A is longer than tab B, the feed needs to increase. If tab B is longer than tab A, the feed must decrease.
2. Insert a 3-mm hex wrench or similar sized screwdriver through the access slot in the rear feed guard and into a slot in the adjustment wheel (see Figure 20).
3. Turn the adjustment wheel in the desired direction to increase or decrease the feed distance (see Figure 20).



NOTE

The adjustment wheel has detent positions which engage every 15 degrees of rotation. Each 15 degrees of rotation will increase or decrease the feed (cutoff) position by 0.02 mm [.0008 in.].

4. Crimp and inspect additional terminals, and repeat steps 2 and 3 until the cutoff tabs are even.

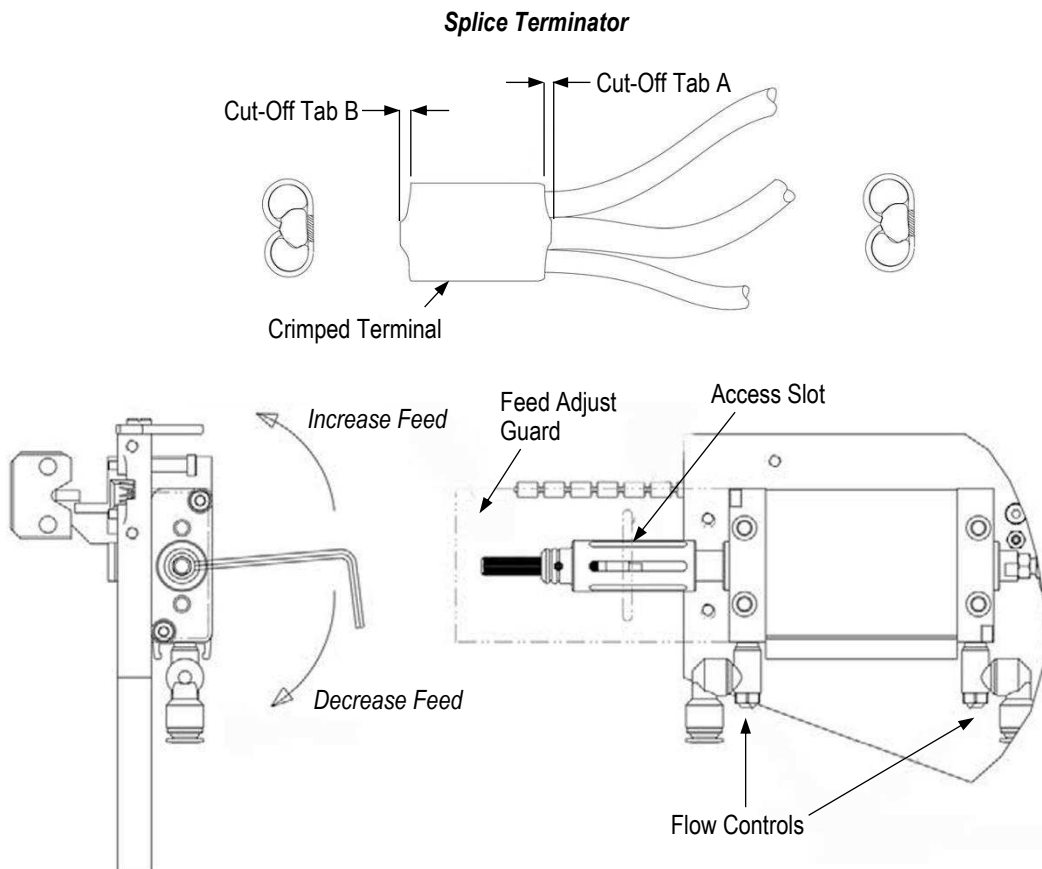

Figure 20

B. For Direct Connect Terminators



DANGER

To prevent personal injury, disconnect the power.

B.1. Feed Finger Engagement



NOTE

It is not necessary for the speed to be fast. Normally, the operator cannot remove a completed termination and insert wires for the next termination before another terminal is in position.

When replacing the feed finger or when converting from one terminal part number to another, the feed finger engagement should be checked and adjusted, if necessary. To set the feed finger engagement, follow these steps:

1. Remove the feed guard (2161780-1).
2. Load the terminal strip until it just reaches the feed finger. Do not load the terminal strip beyond the feed finger.
3. Push the terminal strip forward to ensure that the terminals “click” past the feed finger, and then pull back on the terminal strip to ensure that the feed finger engages the terminal strip firmly (see Figure 21).
4. Re-install the feed guard.

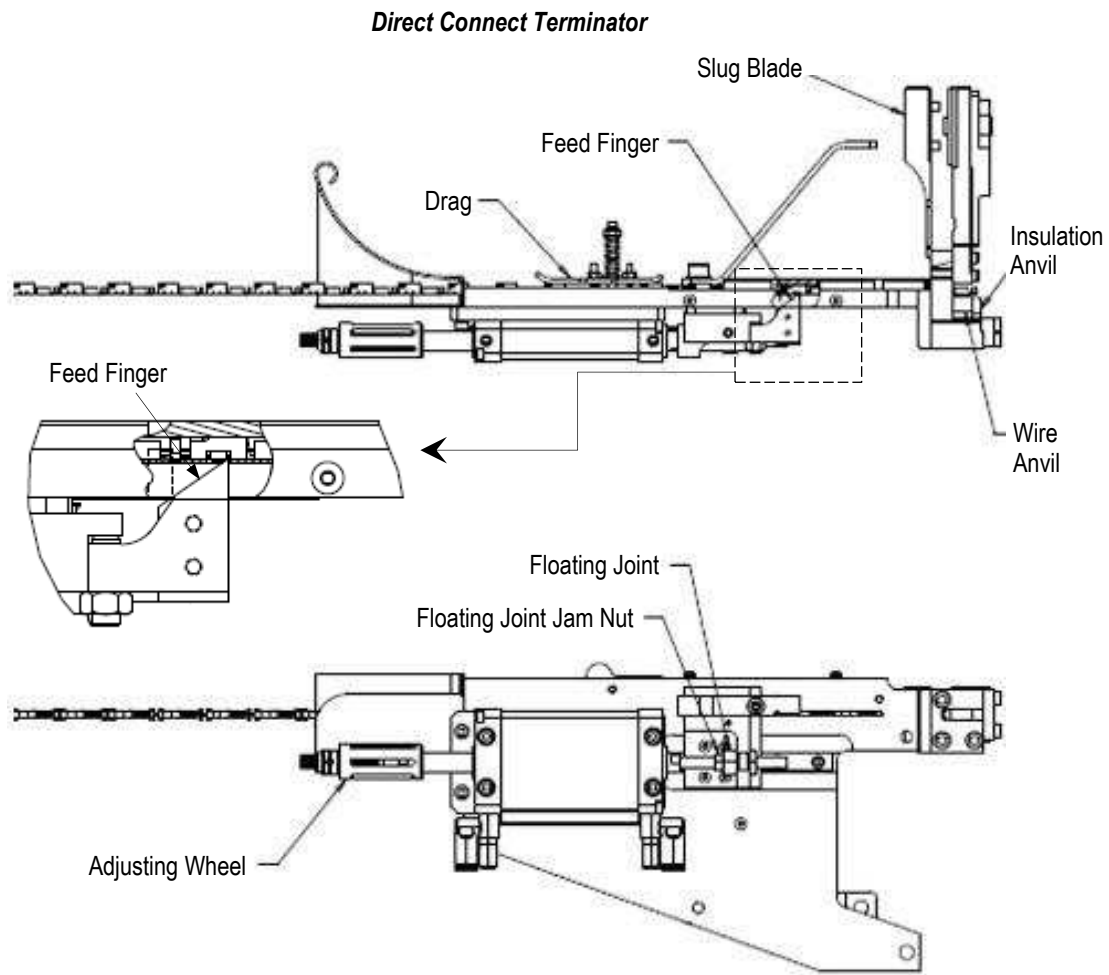

Figure 21

B.2. Flow Control Valves

The flow control valves located on the port fittings of the feed cylinder should be adjusted in such a manner as to slow the feed finger, advancement/retraction, and prevent it from slamming at the end of the stroke. This also helps prevent overfeeding.

To adjust the speed of the feed, turn the valve adjustment *in* to slow the cylinder action, and turn it *out* for faster action.



NOTE

It is not necessary for the feed speed to be fast. Normally the operator cannot remove a completed termination and insert wires for the next termination before another terminal is in position.

B.3. Terminal Strip Drag

The drag must apply sufficient pressure to the terminal strip to prevent pullback of the strip by the feed finger when it is retracted to pick up the next feed point. If necessary, adjust as follows:

1. Increase or decrease drag pressure by compressing or releasing the drag compression springs. The flex nuts, which contain the spring, should be in the same relative position on the drag stud in order to balance spring pressure.
2. The two drag setscrews in the drag are to hold the drag away from the feed plate and assist in the installation of terminals. The setscrews must not be set so that they inhibit terminal drag.
3. Rotate the drag lever to lift the drag from the terminal strip. The drag should pivot on the setscrew.

B.4. Initial Feed Stroke and Position Adjustment

1. Remove the feed guard (2161529-1).
2. Move the feed cylinder shaft to the fully retracted position.
3. Turn the adjusting wheel to the appropriate “L” dimension for the terminal being processed. Refer to the customer drawing for the “L” dimension for AMPLIVAR terminals. If data is not available, set the “L” to the terminal pitch plus half of the gap between the terminals (see Figure 22).

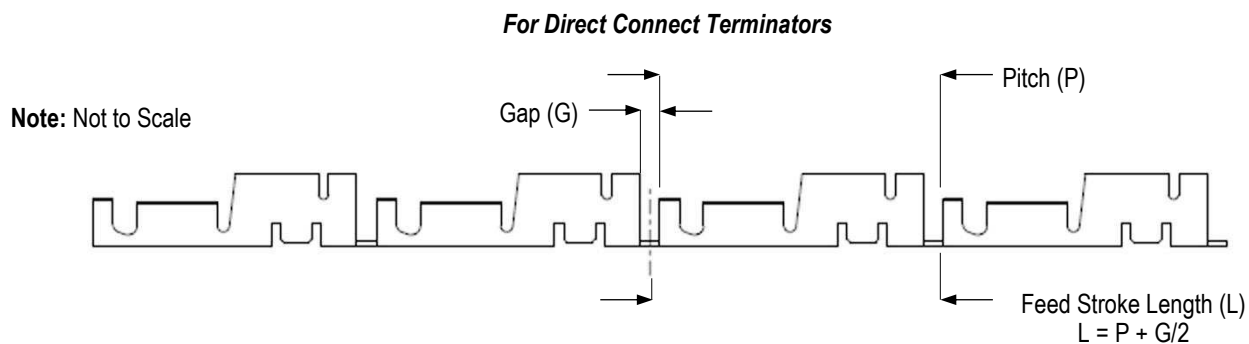

Figure 22

4. Load the terminal strip, and manually feed the strip by pushing the feed cylinder shaft to full extend and full retract position until a terminal is located over the anvil.
5. Loosen the locknut (18029-3) on the floating joint (2168420).



CAUTION

The cylinder shaft must be held using the wrench flats when tightening or loosening the jam nut; otherwise, damage to the cylinder may occur.

6. Hold the feed cylinder shaft fully extended, and adjust the floating joint until the terminal cutoff area aligns with the shear tooling.

7. Tighten the jam nut on the floating joint.
8. Install all guards.
9. Connect electrical and pneumatic power to the terminator.
10. Perform several crimps and measure the terminal cutoff.
11. If the cutoff tabs (front and back) of each terminal differ by more than 0.05 mm [.002 in.], disconnect the electrical and pneumatic power, remove the feed guard, and repeat steps 5 through 10 until the cutoff tabs differ by 0.05 mm [.002 in.] or less.
12. When the cutoff tabs differ by less than 0.05 mm [.002 in.], perform a fine adjustment procedure.

B.5. Feed Position Fine Adjustment



NOTE

Terminal cutoff tabs may start to vary for several reasons, such as prolonged operation, tooling replacement, new terminal reel, or normal wear. If the cutoff tabs become uneven, a fine adjustment may be made using the adjustment wheel.

To make a fine adjustment, follow these steps:

1. Inspect a crimped terminal, then determine if the terminal strip needs more or less feed. If tab "A" is longer than tab "B", feed needs to increase; if tab "B" is longer than tab "A", feed needs to decrease.
2. Insert a 3-mm hex wrench or similar-sized screwdriver through the access slot in the rear feed guard and into a slot in the adjustment wheel. Refer to Figure 23.
3. Turn the adjustment wheel in the desired direction to increase or decrease the feed distance (Figure 23).



NOTE

The adjustment wheel has detent positions which engage every 15 degrees of rotation. Each 15 degrees of rotation will increase or decrease the feed (cut-off) position by 0.02 mm [.0008 in.].

4. Crimp and inspect additional terminals, and repeat steps 2 and 3 until the cut-off tabs are even.

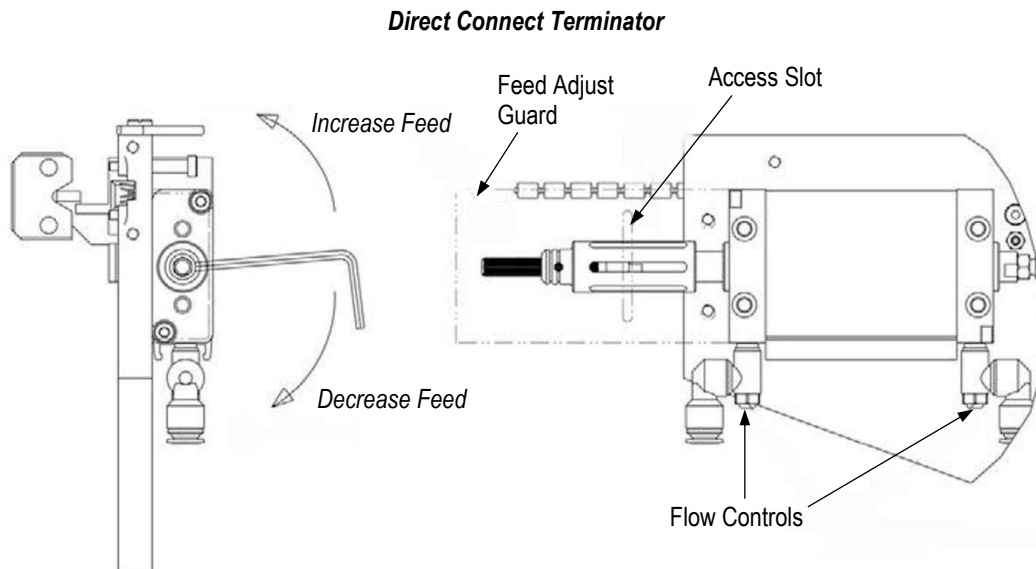

Figure 23

6.3. Adjustment of Ram and Feed Switches

**DANGER**

These adjustments should only be performed by setup technicians. Note that the adjustments are made with power applied and guards open. Be very careful around moving equipment.

A. Ram Extend Switch

1. Depress the ram key to extend the ram.
2. Check the appropriate input for switch actuation.
3. To adjust switch actuation, use a small bladed screwdriver to loosen the sensor on the cylinder. Adjust it until the light on the sensor comes on.
4. Tighten the screw to secure it.
5. Depress the ram key to retract the ram.

B. Ram Retract Switch

1. Check the appropriate input for switch actuation.
2. To adjust switch actuation, use a small bladed screwdriver to loosen the sensor on the cylinder. Adjust it until the light on the sensor comes on.
3. Tighten the screw to secure it.

**NOTE**

Remove the product prior to extending the ram to prevent the terminal from jamming.

C. Feed Extend Switch

1. Check the appropriate input for switch actuation.
2. To adjust switch actuation, use a small bladed screwdriver to loosen the sensor on the cylinder. Adjust it until the light on the sensor comes on.
3. Tighten the screw to secure it.

D. Feed Retract Switch

1. Depress the feed key to retract the feed.
2. Check the appropriate input for switch actuation.
3. To adjust switch actuation, use a small bladed screwdriver to loosen the sensor on the cylinder. Adjust it until the light on the sensor comes on.
4. Tighten screw to secure it.

7. PREVENTIVE MAINTENANCE

Preventive maintenance consists of cleaning, inspection, and lubrication. A scheduled maintenance program should be established. It is very important that the “target area” be kept clean at all times to ensure proper termination.

Remove the terminator covers before performing the following procedures.

**DANGER**

To avoid personal injury, be sure the electrical plug and air supply are disconnected before performing preventive maintenance procedures. Accidentally cycling the terminator could cause personal injury.

A. Cleaning

1. Clean the entire terminator with a clean, dry cloth.
2. Remove all evidence of metal chips and other contamination using a vacuum cleaner, brush, or air hose.

**DANGER**

Compressed air used for cleaning must be reduced to less than 207 kPa [30 psi], and effective chip guarding and personal protective equipment (including eye protection) must be used.

3. Remove any evidence of grease from unlubricated areas and non-moving parts by using an appropriate solvent or similar cleaning fluid.

B. Inspection

1. Inspect the terminator to be sure all parts are secure. Make any repairs necessary to prevent a malfunction.
2. Inspect the terminator for evidence of excessive wear. Replace any unserviceable parts.
3. Inspect all electrical wiring for evidence of broken insulation, chafing, and/or loose connections. Make any repairs that may be necessary by referring to the electrical schematic and wiring drawing shipped with the terminator.
4. Inspect all air lines for loose connections. Make any necessary repairs by referring to the pneumatic diagram (Pneumatic Diagram

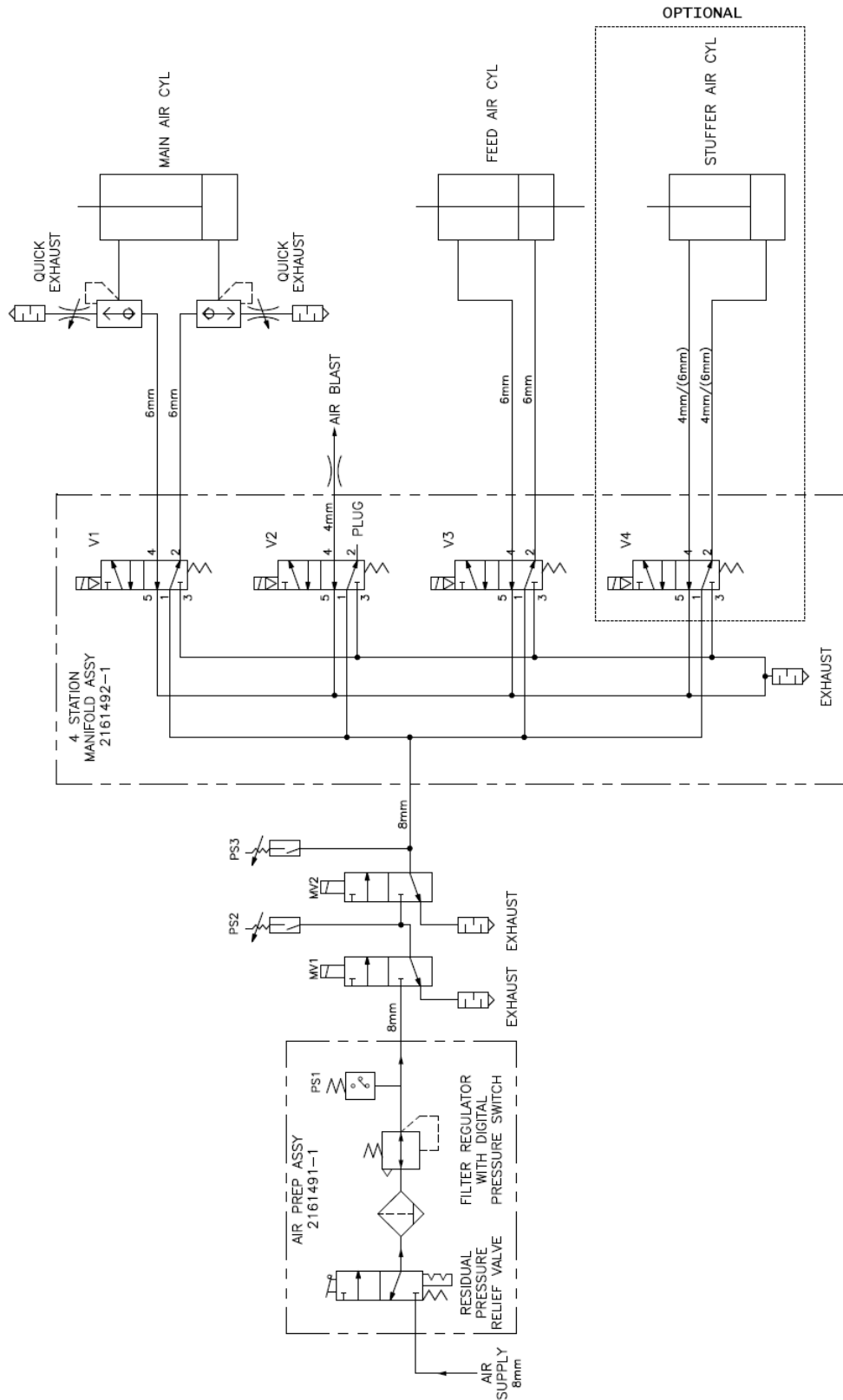

5. Figure 8) (see Paragraph 2.3.).
6. Inspect the filter for excessive condensation. Drain and clean the filter if necessary.

C. Lubrication

1. Lubricate grease fittings, through holes in the frame, using a grease gun containing NLGI-2 EP grease.

**NOTE**

Call TOOLING ASSISTANCE CENTER at the number at the bottom of page 1 for preferred greases.

2. Lubricate the feed finger slide with SAE No. 30 oil.
3. Lubricate the threads of the precision adjustment screw with SAE 30 oil.
4. Lubricate the adjuster yoke slide area with SAE No 30 oil.
5. Remove all excess lubrication.

**NOTE**

For Wire Stuffer, see Section 10.4. For Infinite Splice, see Section 11.4.

8. ERROR CODES AND I/O SCREEN

8.1. Error Codes

If an error occurs, an error code will be displayed on the terminator (see Figure 24 for error codes).

Error Code
(See Note)



Note: This error code indicates that the feed cylinder did not extend.

ERROR CODE	ERROR DESCRIPTION
E001	The host is inhibiting operation.
E002	The guard interlock is open.
E003	The insert interlock is open.
E004	The safety circuit is not operational.
E005	The control panel is not communicating with the CPU.
E030	No air pressure.
E031	Pressure switch stuck "on".
E032	Feed cylinder is not extended.
E033	Ram cylinder is not retracted.
E034	Ram cylinder (did not leave home switch).
E035	Feed cylinder is not retracted.
E036	Feed cylinder did not extend.
E037	Ram cylinder is not extended.
E038	Feed cylinder is retracted.
E039	Ram cylinder did not retract.
E040	Feed cylinder did not retract.
E041	Problem with main air circuit.

Figure 24

8.2. I/O Screen

Connect the electrical plug and air supply, then depress the power key. Select manual mode using the mode key. This will display the terminator inputs on the screen. Refer to Figure 25.

Shaded circle indicates that the switch is actuated.

> indicates the extend switch is on.

< indicates the retract switch is on.

- indicates neither switch is on.



NOTE

Refer to Paragraph 6.3 for adjustment to ram and feed switches.

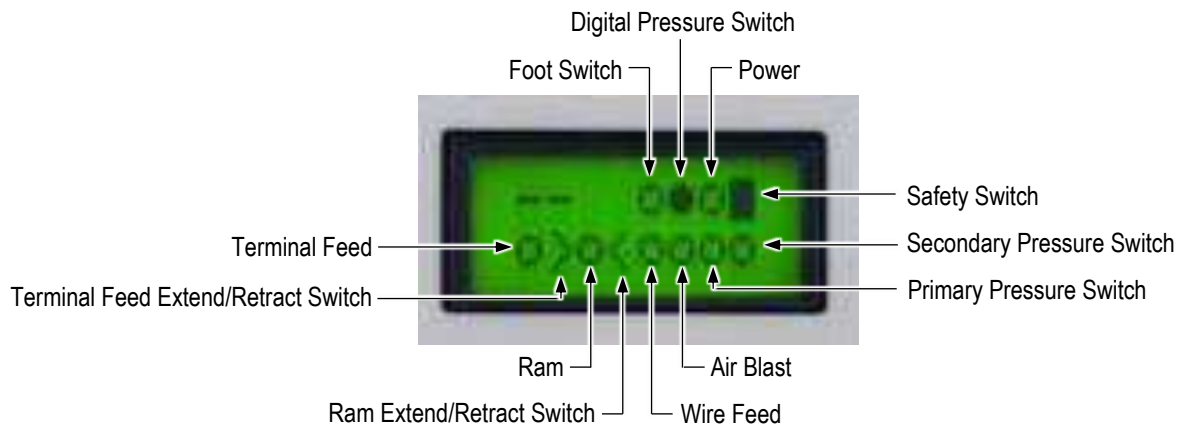

Figure 25

9. REPLACEMENT AND REPAIR

9.1. Splice Terminators

The splice terminator can be disassembled using the procedures in this section and the terminator assembly drawings. These procedures primarily pertain to the replacement of parts that are considered to be recommended spares and should be stocked by the customer.



DANGER

To avoid personal injury when making repairs or replacements, be sure the electrical plug and air supply are disconnected. Accidentally cycling the terminator could cause personal injury.

A. Shear Blade and/or Crimper Replacement

1. Remove the anvil guard and the ram guard by removing screws.
2. Remove the two screws securing the crimper and shear blade to the crimper guide. Note the orientation of these parts for replacement purposes.
3. Install the new shear blade and crimper using the reverse of the removal procedure.

B. Anvil, Anvil Holder, and Guide Shear Replacement

1. Remove the anvil guard and ram guard by removing the screws.
2. Remove the screws securing the stripper plate to the anvil holder.
3. Remove the anvil from the anvil holder.
4. If only replacing the anvil, install the new anvil using the reverse of the removal procedure.
5. If only replacing the guide shear, loosen the screws, and remove the guide. Install the new guide shear by using the reverse of the removal procedure.

6. If only replacing the anvil holder, remove the three screws securing it to the frame. Install the new anvil holder, and mount the guide shear by using the reverse of the removal procedure. Refer to Paragraph 4.1. to check the pre-loading alignment and Paragraph 4.2 to align the tooling.
7. Install the guards.

C. Feed Finger Replacement

1. Remove the two screws securing the feed cylinder to the feed plate. Pull the feed cylinder away from the feed plate to disengage the feed cylinder adapter from the switch actuator.
2. Remove the two screws and feed finger holder retainer in back of the feed plate; then remove the feed finger holder from the front.
3. Loosen the self-locking nut, and remove the screw and compression spring; then remove the feed finger from holder.
4. If necessary, install pin in the new feed finger. Install the feed finger using the reversed removal procedure.
5. Make the feed adjustments as described in Paragraph 6.2.

D. Pneumatic System Repairs

When it is necessary to make repairs to the pneumatic system, refer to the pneumatic diagram (Pneumatic Diagram

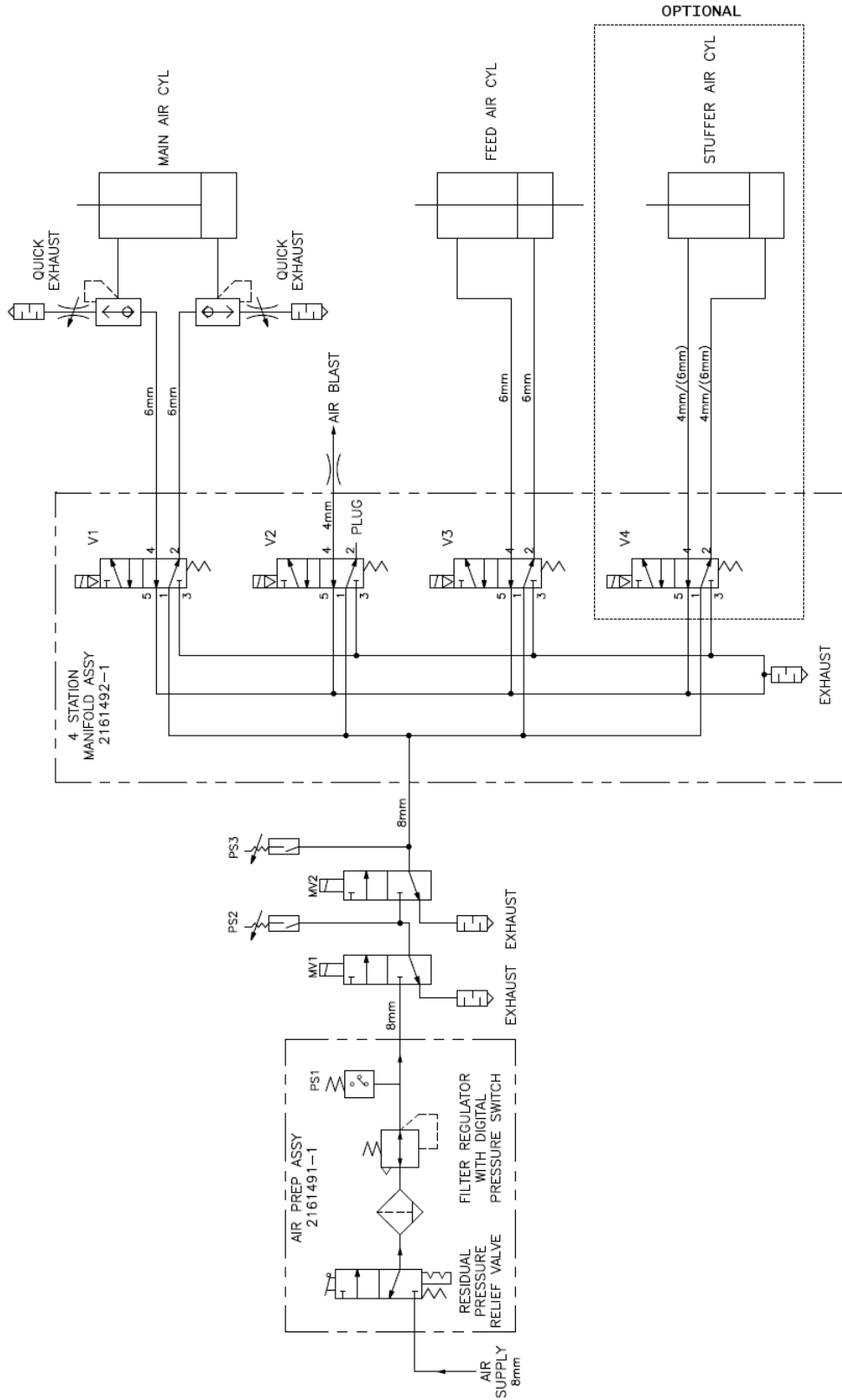

Figure 8).

E. Electrical System Repairs

To make repairs to the terminator system, refer to the terminator schematic and electrical drawings.

F. Tooling Matrix

Refer to TE Drawing [2161795](#) (provided with the documentation package) for the tooling matrix.

9.2. Direct Connect Terminators

The terminator can be dis-assembled using the following procedure and the terminator assembly drawings.

The procedure primarily pertains to replacing parts that are considered to be recommended spares and should be stocked by the customer.



DANGER

To avoid personal injury when making repairs or replacements, be sure the electrical plug and air supply are disconnected. Accidentally cycling the terminator could cause personal injury.

A. Shear Blade and/or Crimper Replacement

1. Remove the anvil guard and ram guard.
2. Remove the two screws in the slug blade, and remove the slug blade from the ram. Note the orientation of these parts for replacement purposes.
3. Install the new slug blade so that it is seated against the bottom of the slot in the ram.
4. Perform the pre-loading alignment check as described in Paragraph 4.1.
5. Install the anvil guard and the ram guard.

B. Crimper Replacement

1. Remove the screws securing the ram guard. Remove the ram guard.
2. Remove the screws from the straw stop.
3. Remove the button head screws to remove the insulation crimper, wire crimper, insulation disc, and spacer (if used). Pull the crimpers from the ram along with the loose straw stop.
4. Install the replacement crimpers with the straw stop between them. The wire crimper must be against the bottom of the slot in the ram and the insulation crimper must be against the appropriate surface of the insulation disc.
5. Install the straw stop to the wire shear.
6. Perform the pre-loading alignment check as described in Paragraph 4.1.
7. Install the ram guard.

C. Anvil Replacement

1. Remove anvil guard by removing the appropriate screws.
2. Remove the retainer plate.
3. Remove the anvil from the anvil holder.
4. Install the anvils and then the retainer plate so that the anvils are secured on the anvil holder.
5. Perform the pre-loading alignment check as described in Paragraph 4.1.
6. Install the anvil guard.

D. Feed Finger Insert Replacement

1. Remove the two flat head screws securing the feed finger, and replace the feed finger insert.
2. Attach the feed finger insert with the two flat head screws.
3. Loosen the self-locking nut, and remove the screw and compression spring; then remove the feed finger from holder.
4. If necessary, install the pin in the new feed finger. Install the feed finger using the reverse of the removal procedure.
5. Make the feed adjustments as described in Paragraph 6.2.

E. Pneumatic System Repairs

When it is necessary to make repairs to the pneumatic system, refer to the pneumatic diagram (Pneumatic Diagram

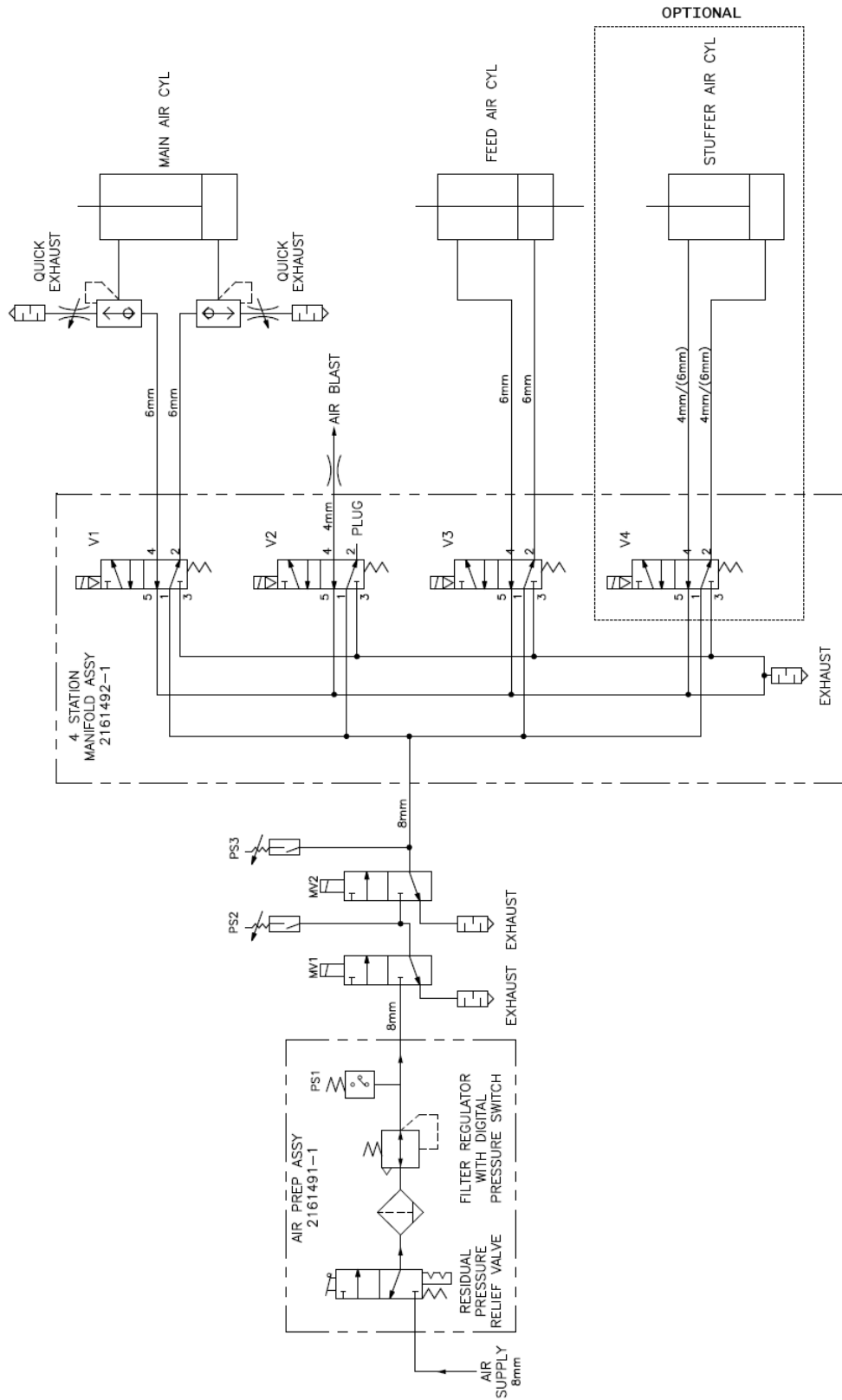

Figure 8).

F. Electrical System Repairs

To make repairs to the terminator system, refer to the terminator schematic and electrical drawings.

G. Product Hold-Down Replacement

1. Remove the product hold-down.
2. Manually lower the ram, and install the new product hold-down to the feed plate so the shear edge is against the shear blade.
3. Perform the pre-loading alignment check as described in Paragraph 4.1.

H. Tooling Matrix

Refer to drawing 2161795 (provided with the documentation package) for the tooling matrix.

10. OPTIONAL WIRE STUFFER ASSEMBLY

Wire stuffer assembly 2161635-1 is used when a workpiece (stator, bobbin, etc.) requires two or more terminations that have different wire size combinations.

The addition of the wire stuffer assembly allows a single terminal part number to be used for all of the terminations on the workpiece. This is accomplished by using a terminal for the largest wire combination on the workpiece, then automatically “stuffing” an extra piece of magnet wire in the smallest wire combination during the crimp cycle. Combining the wire stuffer assembly with automatic sequencing of the crimp height adjustment provides the following advantages:

- Only one terminal is required for all terminations on a single workpiece, which eliminates the need to stock multiple terminals.
- A workpiece can be processed completely in one operation, which eliminates the need for batch processing and tooling changeover or even a second terminating machine.



NOTE

Careful consideration of your application is necessary to determine the correct terminal part number and magnet wire gauge to be used in the stuffer in order to obtain the desired results. It is highly recommended contacting TE Connectivity application tooling specialist for assistance in choosing the correct terminal and stuffer wire when using the wire stuffer assembly.

10.1. Wire Stuffer Assembly Installation

When the wire stuffer assembly is ordered installed on the terminator, the wire stuffer assembly and associated parts will be installed and adjusted prior to shipment. In this case, no further assembly or adjustment should be necessary. Refer to Figure 26.

When the wire stuffer assembly is ordered separately (for installation on an existing terminator), the installation process is as follows:

1. Ensure that the air and electrical power is disconnected.



DANGER

To avoid personal injury when installing accessories, disconnect the air and electrical power.

2. Carefully review wire stuffer assembly drawing 2161635 supplied with the assembly. Before proceeding, make sure the wire stuffer assembly contains all items listed on the Bill of Material.

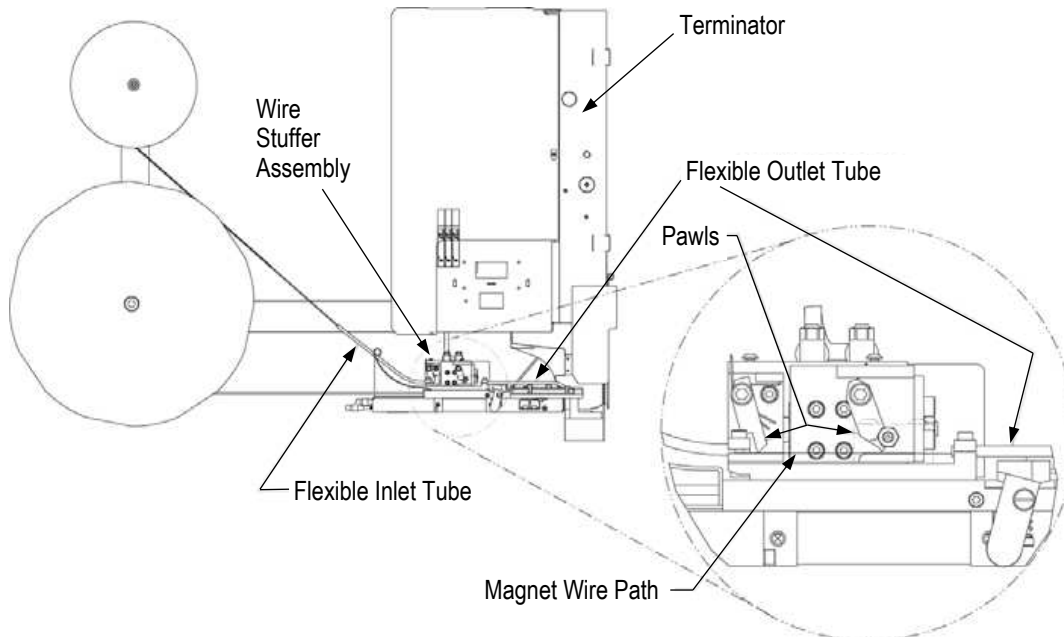
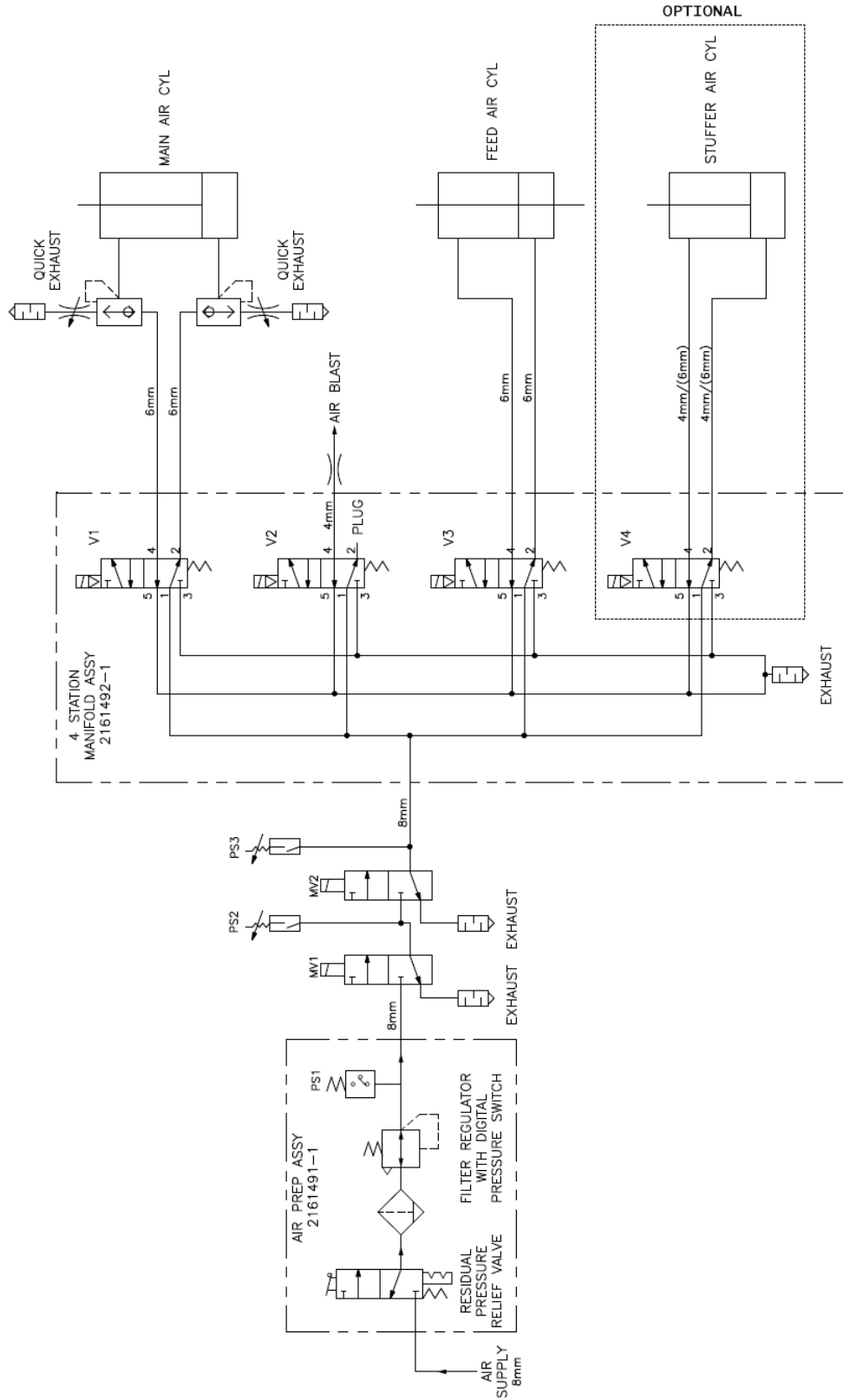

Figure 26

3. Remove the stuffer guard, and mount the wire stuffer assembly to the terminator feed plate as shown on the drawing.

4. Insert the wire guide tube into the terminator strip guide cover as shown on the drawing.
5. Remove the existing terminator angle bracket from the reel support arm, and replace it with the new reel support bracket included with the wire stuffer assembly. Transfer the terminator reel support shaft to the new reel support bracket.
6. Remove the terminator main cover to expose the pneumatic valve assembly. The terminator is equipped with a blank station in the valve assembly for the wire stuffer assembly.
7. Remove the blank station, and install the solenoid valve supplied with the wire stuffer assembly. Use caution when installing the valve to avoid dislodging or damaging any seals or gaskets.
8. Connect the wire stuffer cylinder to the terminator valve manifold using the airline tubing provided. Refer to the wire stuffer assembly drawing or Pneumatic Diagram



9. Figure 8 (pneumatic diagram).

10. Place the reel of AMPLIVAR terminals on the reel support shaft, and place a spool of appropriate magnet wire size 18 to 22 AWG or 18 AWG stranded bare copper grounding wire on the wire stuffer reel post. Thread the magnet wire into the flexible tubing connected to the wire stuffer and continue feeding the wire until it passes under both pawls and into the flexible output tubing.
11. Continue feeding the magnet wire until it enters the terminator feed track and is even with the shear tooling.

10.2. Wire Stuffer Assembly Adjustment

The wire stuffer assembly has a pneumatic cylinder with a fixed stroke length to feed a fixed amount of magnet wire into the crimp area when actuated. The adjustments provided on the wire stuffer assembly consist of flow controls, cylinder rod mount, plunger mount position, and plunger engagement.

A. Flow Controls

The fittings located on the cylinder ports are equipped with threaded flow controls to limit the extend speed and retract speed of the air cylinder. Adjust the controls to limit the cylinder speed for smooth operation (see Figure 27).

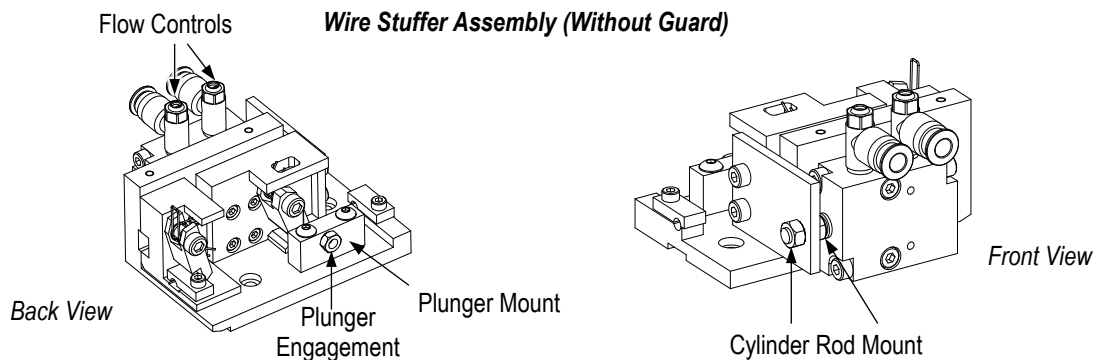

Figure 27

B. Cylinder Rod Mount

The cylinder rod mount is used to adjust the forward position of the feed pawl. With the cylinder fully extended, the feed pawl must travel beyond the spring plunger and allow the spring plunger to extend behind the pawl (see Figure 27).

If the plunger remains depressed by the pawl, loosen the two nuts on the cylinder shaft and adjust the cylinder rod mount forward until the plunger is released behind the pawl. If additional adjustment is needed, the plunger mount may also be adjusted to properly position the plunger.

C. Wire Stuffer Plunger Mount

The plunger mounting block may be moved forward or backward by loosening the two mounting screws and sliding the mount until the plunger extends behind the feed pawl (when the feed cylinder is fully extended). Tighten both mounting screws after adjustment.

D. Wire Stuffer Plunger Engagement

The plunger must be adjusted so that the feed pawl is raised during the retract stroke and the plunger is depressed during the feed stroke. The approximate adjustment dimension is shown.

10.3. Operation

The operation of the wire stuffer assembly on the terminator is accomplished by manually depressing the wire stuffer key on the control panel. Refer to Paragraph 2.2.

The operation of the wire stuffer assembly on the terminator is programmable by using the CQM II. Refer to customer manual [409-32025](#) (CQM II sequencing guide) for instructions on programming the wire stuffer assembly as part of a sequence.

The terminal feeding mode must be set to Pre-Feed Extend. This will reduce wire feeding issues during operation. See Feed Mode row in section 2.2.

10.4. Maintenance

Maintenance of the wire stuffer assembly consists of cleaning, inspection, and lubrication.

1. Weekly, or every 50,000 cycles, remove the wire stuffer cover and clean all debris using a small brush or compressed air. Compressed air used for cleaning must be reduced to less than 207 kPa [30 psi] and effective chip guarding must be used.
2. Inspect the wire stuffer assembly to be sure all parts are secure.
3. Lubricate both pawls by applying a drop of SAE 30 oil to the pivot pin.
4. Re-install the cover.

11. OPTIONAL INFINITE SPLICE ASSEMBLY

Infinite splice assembly is used when a workpiece (stator, bobbin, etc.) requires two or more bussed terminations (see Figure 28).

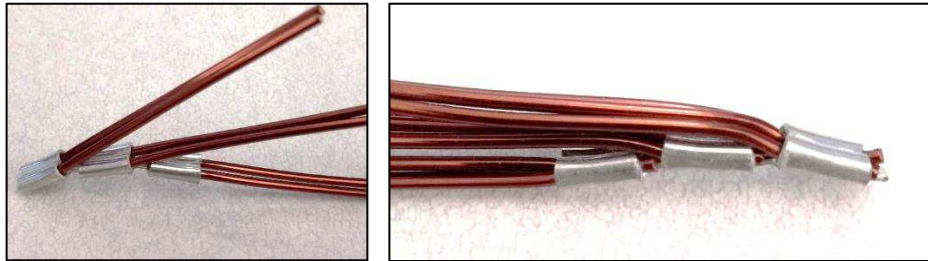

Figure 28

The addition of the infinite splice assembly allows a single terminal part number to be used for all the terminations in the workpiece. This is accomplished by creating different wire combinations to be used for each crimp, while the carrier strip remains unbroken until the desired chain is completed. Combining the infinite splice assembly with automatic sequencing of the crimp height adjustment provides the following advantages:

- Only one terminal is required for all terminations on a single workpiece; which eliminates the need to stock multiple terminals.
- A workpiece can be processed completely in one operation; which eliminates the need for batch processing and tooling changeover, or even a second terminating machine.
- Combinations can be made that allow for more than three magnet wires to be connected.
- Combinations can be made with an unlimited number of terminals.



NOTE

To obtain the desired results when using the Infinite Splice Assembly, careful consideration of the application is necessary to determine the correct terminal part number and magnet wire gauge to be used. It is highly recommended to contact a TE Connectivity application tooling specialist for assistance in choosing the correct terminal and wire when using the Infinite Splice assembly.

11.1. Infinite Splice Assembly Installation

1. When the infinite splice assembly is ordered with a terminating machine, the infinite splice assembly and associated parts will be installed and adjusted prior to shipment. In this case, no further assembly or adjustment should be necessary.
2. When the infinite splice assembly is ordered separately (for installation on an existing machine), the installation process is as follows:
 - a. Ensure the air and electrical power is disconnected



DANGER

To avoid personal injury when installing accessories, disconnect the air and electrical power.

- b. Carefully review the infinite splice assembly drawing supplied with the assembly. Before proceeding, verify the infinite splice assembly contains all items listed on the Bill of Material.
- c. Remove the ram and replace with the new ram assembly.
- d. Install the shear, plunger and retainer, as illustrated in Figure 29.

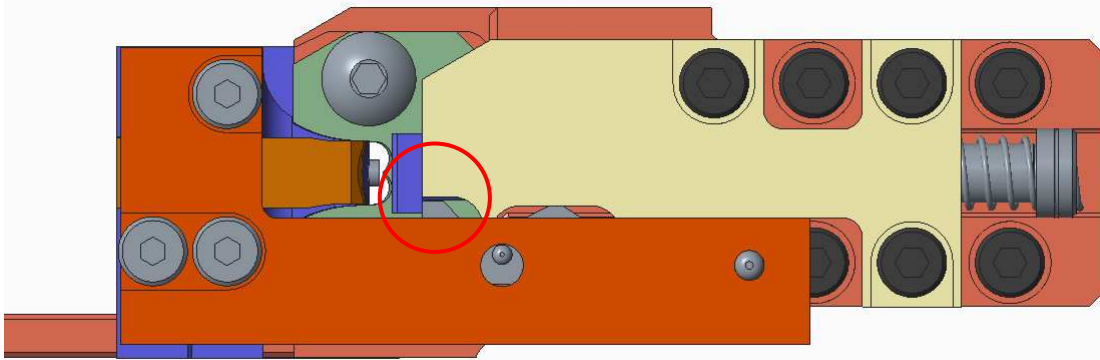

Figure 29

11.2. Infinite Splice Assembly Adjustment

The infinite splice assembly requires a plunger that interacts with the retainer. It is important to ensure that these two parts interact and move correctly. Manually close the tooling to check for the following steps:

1. The plunger depresses the raised geometry on the retainer and clicks into a depressed location (see Figure 29).
2. When the tooling is manually opened, the plunger kicks off of the retainer, causing the retainer surface to return to its raised position and allows the plunger to spring back freely (see Figure 30).

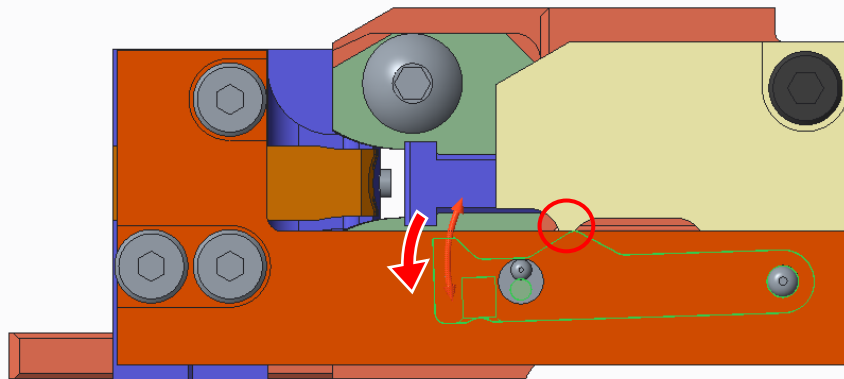

Figure 30 (cont'd)

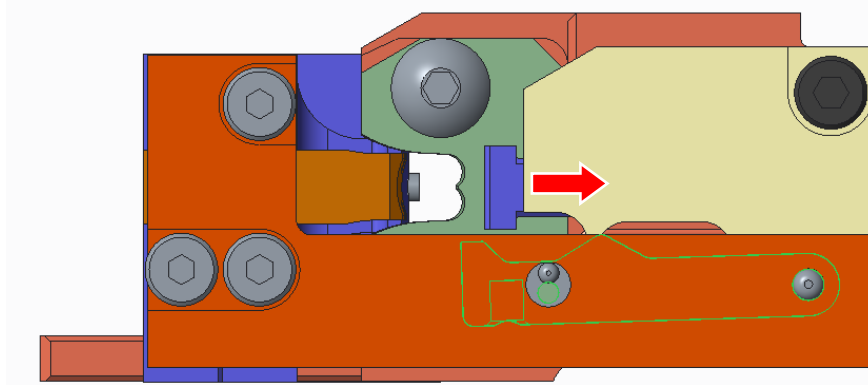

Figure 30 (end)

11.3. Operation

The operation of the infinite splice assembly on the machine is accomplished by creating a sequence of crimps to form the complete connection across the uncut carrier strip. This sequence must incorporate parts that do not cut the carrier strip, and the final crimp must cut the carrier strip.



NOTE

The Infinite Splice Assembly cannot be used at the same time as the Wire Stuffer Assembly. The user must choose one assembly per application.

While in calibration mode, each crimped terminal is cut from the carrier strip to properly measure the desired crimp height. This creates an easy method to establish the correct crimp height for each application.



NOTE

To properly determine the correct crimp heights, turn sequencing OFF on the CQM and manually use the arrows to the next crimp sequence once the previous crimp sequence is calibrated.

11.4. Maintenance

Visually inspect the stripper-plunger mechanism for excessive wear or damage. Replace if excessive wear or damage is detected. At bi-weekly or 500,000 cycle interims, apply grease lightly.

12. REVISION SUMMARY

Revisions to this customer manual include:

- Added 18 AWG stranded wire used in wire stuffer.
- Added feed comments when using wire stuffer.