

5mm Silicon PIN Photodiode , T-1 3/4 EAPDLP05RDDA1



Features

- Fast response time
- High photo sensitivity
- Small junction capacitance
- Pb free
- This product itself will remain within RoHS compliant version.

Description

EAPDLP05RDDA1 is a high speed and high sensitive PIN photodiode in a standard 5 ϕ plastic package. Due to its water clear epoxy the device is sensitive to visible and infrared radiation.

Applications

- High speed photo detector
- Security system
- Camera

Device Selection Guide

Chip Materials	Lens Color
Silicon	Water clear

Absolute Maximum Ratings (Ta=25°C)

Parameter	Symbol	Rating	Unit
Reverse Voltage	V_R	32	V
Power Dissipation	P_d	150	mW
Lead Soldering Temperature	T_{sol}	260	°C
Operating Temperature	T_{opr}	-25 ~ +85	°C
Storage Temperature	T_{stg}	-40 ~ +100	°C

Notes: *1:Soldering time \leq 5 seconds.

Electro-Optical Characteristics (Ta=25°C)

Parameter	Symbol	Min.	Typ.	Max.	Unit	Condition
Range Of Spectral Bandwidth	$\lambda_{0.5}$	400	---	1100	nm	-----
Wavelength Of Peak Sensitivity	λ_p	---	940	---	nm	-----
Open-Circuit Voltage	V_{OC}	---	0.39	---	V	$E_e=5m W/cm^2$ $\lambda_p=940nm$
Short- Circuit Current	I_{SC}	---	40	---	μA	$E_e=1m W/cm^2$ $\lambda_p=940nm$
Reverse Light Current	I_L	36	40	---		$E_e=1m W/cm^2$ $\lambda_p=940nm$ $V_R=5V$
Reverse Dark Current	I_D	---	5	30	nA	$E_e=0m W/cm^2$ $V_R=10V$
Reverse Breakdown Voltage	V_{BR}	32	170	---	V	$E_e=0m W/cm^2$ $I_R=100 \mu A$
Total Capacitance	C_t	---	18	---	pF	$E_e=0m W/cm^2$ $V_R=5V$ $f=1MHz$
Rise Time/ Fall Time	t_r / t_f	---	45/45	---	nS	$V_R=10V$ $R_L=1K \Omega$
View Angle	201/2	--	80	--	deg	$I_f=20mA$

Typical Electro-Optical Characteristics Curves

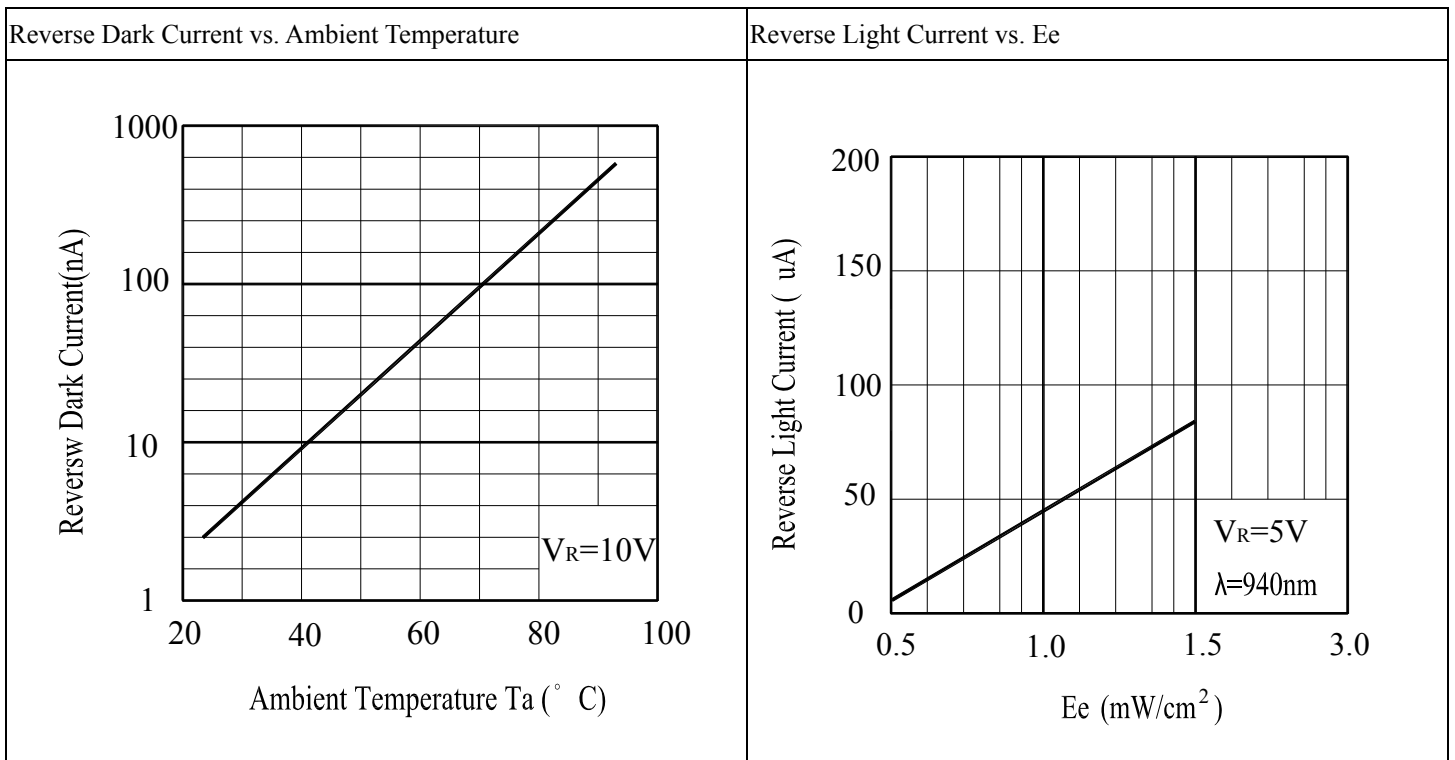
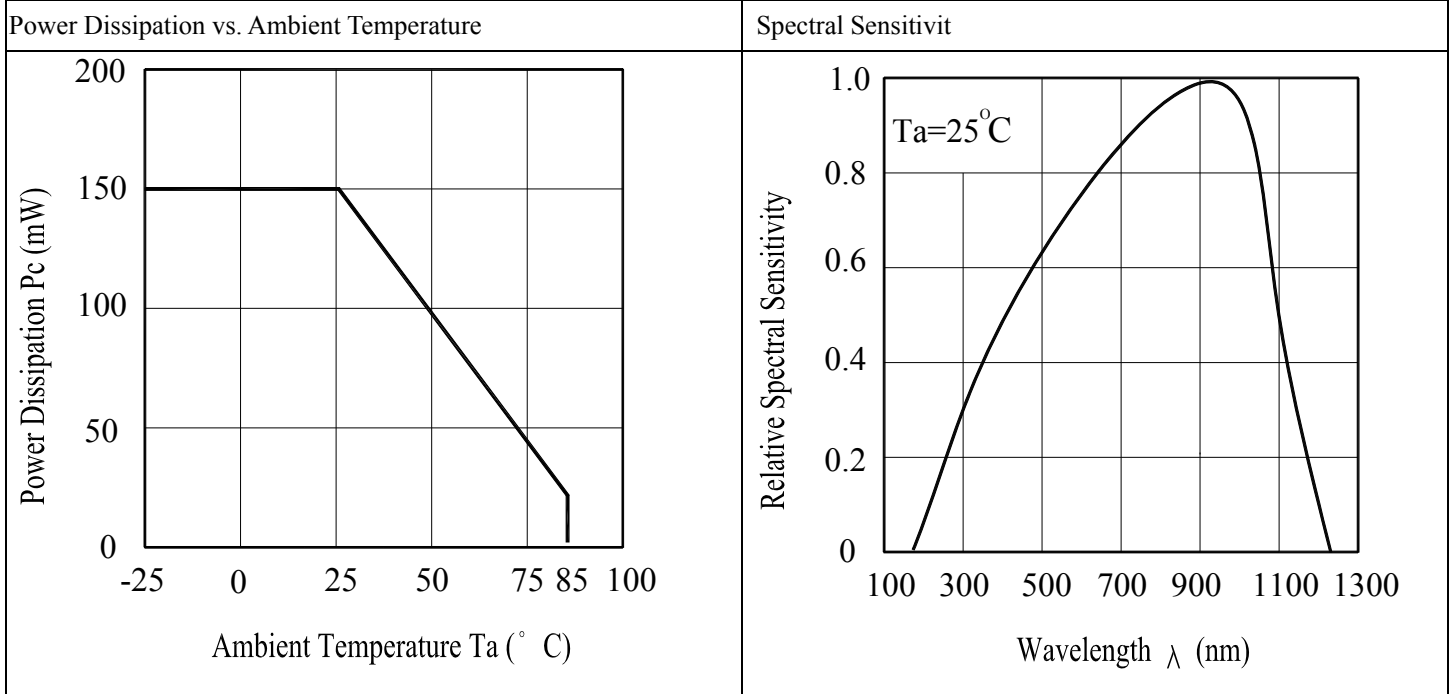

Terminal Capacitance vs. Reverse Voltage

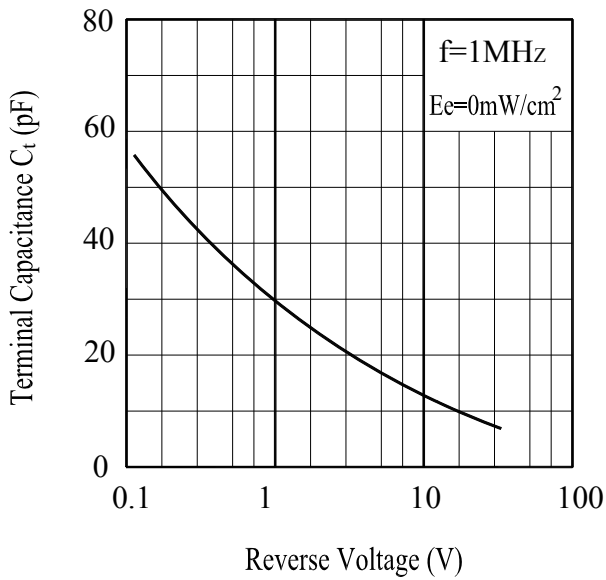

Response Time vs. Load Resistance

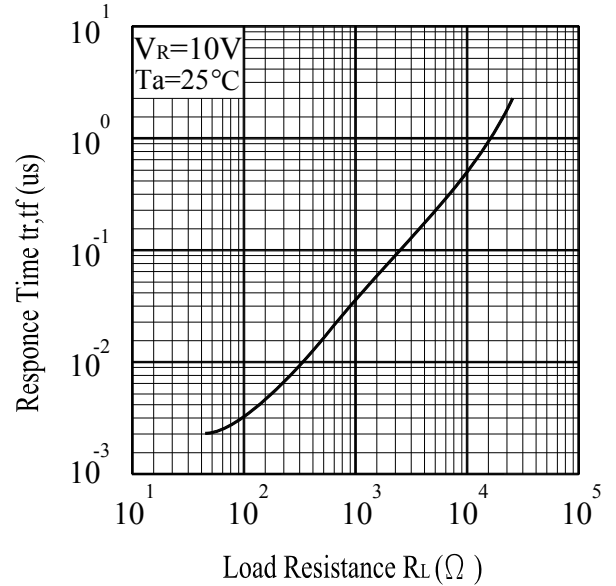

Relative Reverse Light Current vs. Ambient Temperature

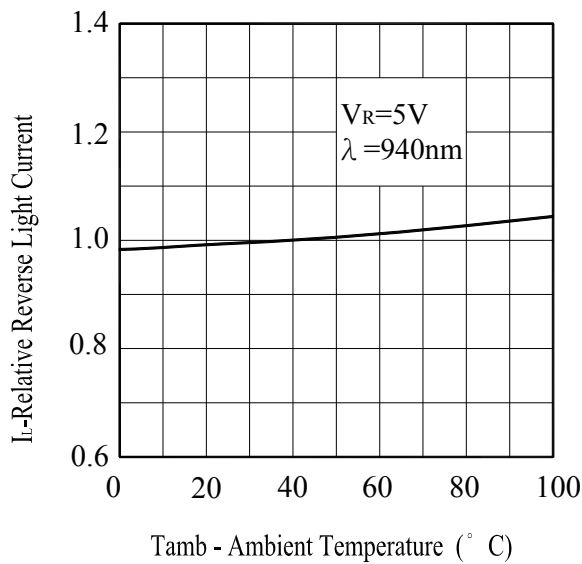

Relative Radiant Intensity vs. Angular Displacement

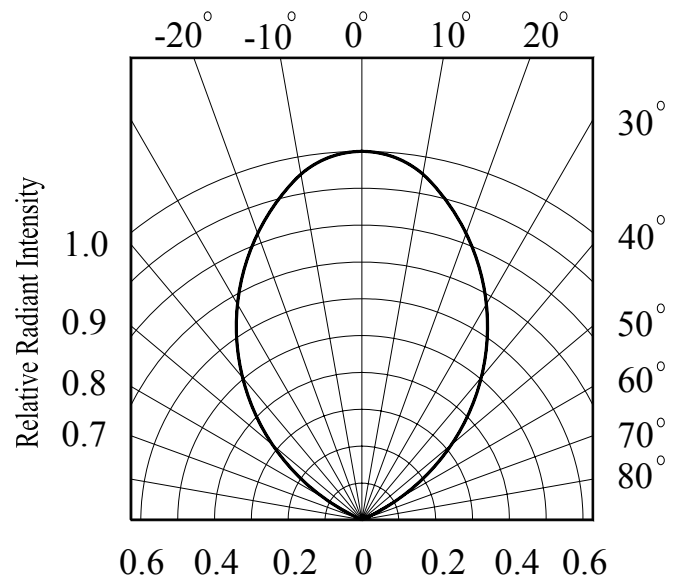

Package Dimension

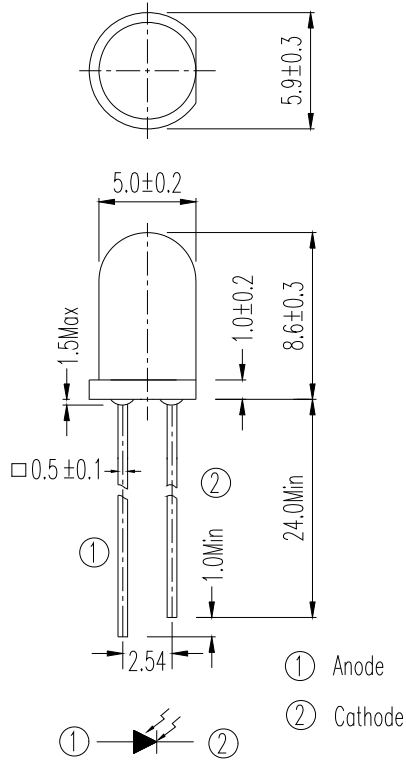

Note: Tolerances unless dimensions ± 0.25 mm

Label Form Specification

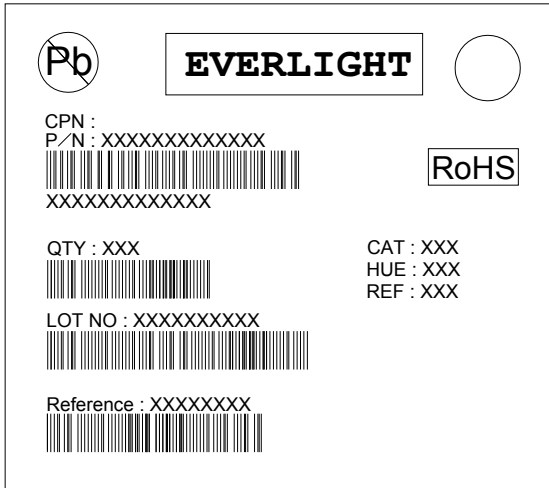

- CPN: Customer's Product Number
- P/N: Product Number
- QTY: Packing Quantity
- CAT: Luminous Intensity Rank
- HUE: Dom. Wavelength Rank
- REF: Forward Voltage Rank
- LOT No: Lot Number
- X: Month
- Reference: Identify Label Number

Packing Specification

■ Anti-electrostatic bag

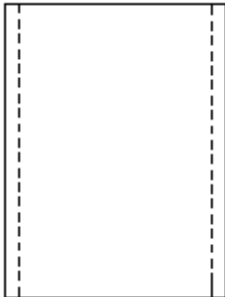

■ Inner Carton

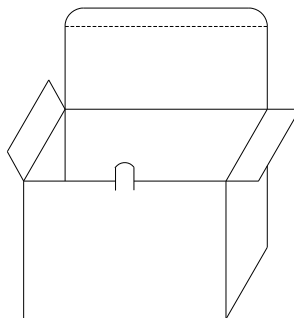

■ Outside Carton

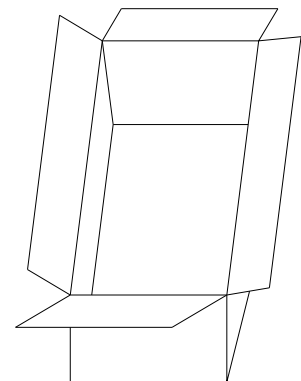

■ Packing Quantity

1. 500 PCS/1 Bag, 5 Bags/1 Inner Carton
2. 10 Inner Cartons/1 Outside Carton

Notes

1. Above specification may be changed without notice. Everlight Americas will reserve authority on material change for above specification.
2. When using this product, please observe the absolute maximum ratings and the instructions for using outlined in these specification sheets. Everlight Americas assumes no responsibility for any damage resulting from use of the product which does not comply with the absolute maximum ratings and the instructions included in these specification sheets.
3. These specification sheets include materials protected under copyright of Everlight Americas corporation. Please don't reproduce or cause anyone to reproduce them without Everlight Americas's consent.