

BGA700L16

Low Noise Amplifier for IEEE 802.11a/b/g/n

THE BGA700L16 is a Wireless LAN dual band Low Noise Amplifier. The amplifier comprises a single stage amplifier for the 2.45 GHz band and a two-stage amplifier to meet the requirements of the 4.9 to 5.95 GHz band. The complete circuitry, including a temperature stabilization block, fits on one die and needs no external matching elements.

One of the challenges of Wireless LAN application designers is to maximize network coverage and data throughput. The receiver system noise figure determines sensitivity, network coverage and data throughput.

The BGA700L16 uses a combination of Silicon Germanium Carbon epitaxy proprietary process and a low ohmic on chip ground contact from Infineon Technologies to deliver the world best-in class noise figure for wireless LAN systems.

The BGA700L16 ships as bare die or in a low profile Tiny Small Leadless Package code-named TSLP-16. The package dimensions are 2.3 x 2.3 x 0.39 mm³.



Applications

- 802.11a/b/g/n

Features

- Input/output 50 Ω matched internally
- SiGe:C process
- Shut down mode
- Temperature stabilization

Benefits

- Extended coverage
- Ultra-low noise figure
- Small form factor
- High level of integration
- Low cost

TSLP-16 Package

2.3 x 2.3 x 0.39 mm³

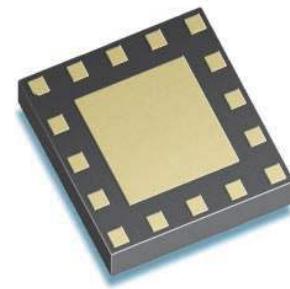

www.infineon.com/smallsignaldiscretes

Small Signal Discretes



Never stop thinking

Application Circuit

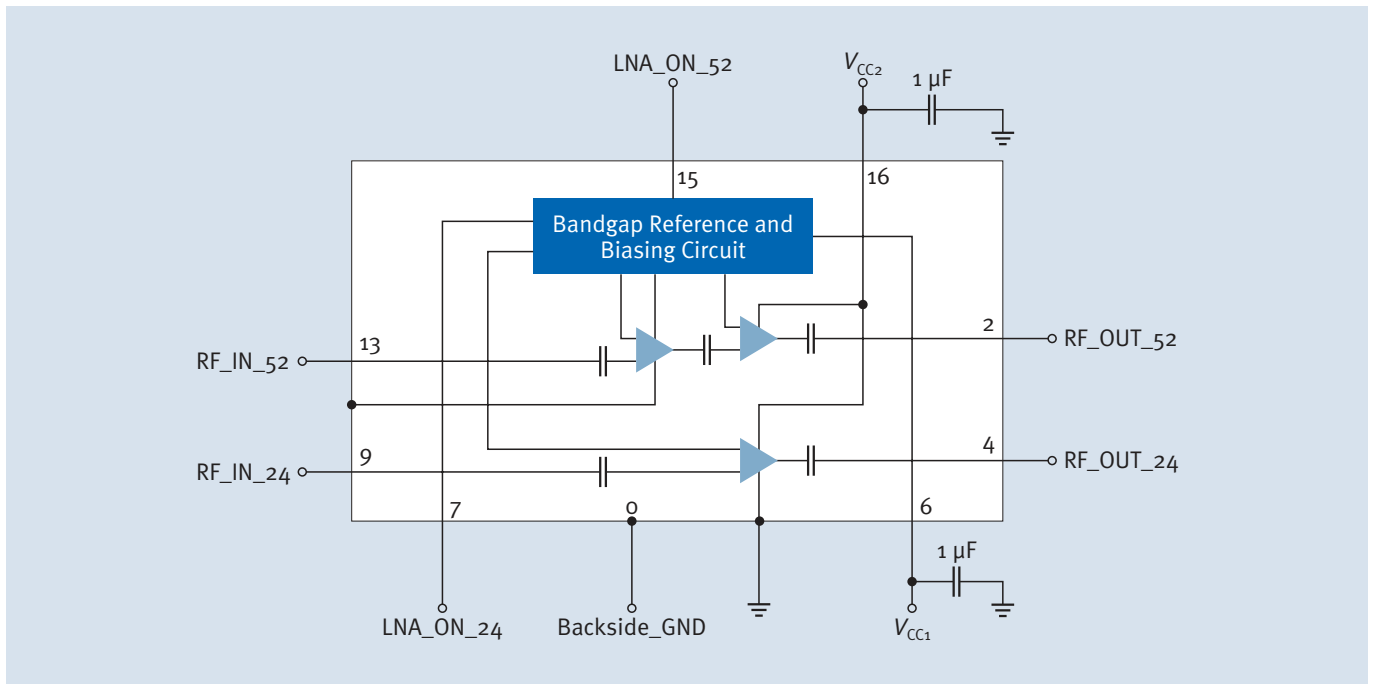

Performance

Band [GHz]	Supply Voltage [V]	Supply Current [mA]	Gain [dB]	Noise Figure [dB]	Input P1dB [dB]
2.4	2.4 – 3.3	11	15	0.9	-10
5.6	2.4 – 3.3	17	21	1.3	-10



How to reach us:
<http://www.infineon.com>

Published by
Infineon Technologies AG
 81726 Munich, Germany

© Infineon Technologies AG 2006.
 All Rights Reserved.

Legal Disclaimer

The information given in this Product Brief shall in no event be regarded as a guarantee of conditions or characteristics ("Beschaffenheitsgarantie"). With respect to any examples or hints given herein, any typical values stated herein and/or any information regarding the application of the device, Infineon Technologies hereby disclaims any and all warranties and liabilities of any kind, including without limitation warranties of non-infringement of intellectual property rights of any third party.

Information

For further information on technology, delivery terms and conditions and prices please contact your nearest Infineon Technologies Office (www.infineon.com).

Warnings

Due to technical requirements components may contain dangerous substances. For information on the types in question please contact your nearest Infineon Technologies Office.

Infineon Technologies Components may only be used in life-support devices or systems with the express written approval of Infineon Technologies, if a failure of such components can reasonably be expected to cause the failure of that life-support device or system, or to affect the safety or effectiveness of that device or system.

Life support devices or systems are intended to be implanted in the human body, or to support and/or maintain and sustain and/or protect human life. If they fail, it is reasonable to assume that the health of the user or other persons may be endangered.

Ordering No. B132-H8884-X-X-7600
 Printed in Germany
 PS 01071. nb