

Universal Timer Controller

Features

- Auto-shut off output once time-out
- Button to ON/OFF/RESET timer
- Available timer with high precision same as AC 50/60Hz
- Build-in RC oscillator
- Drive external SCR
- Support 50/60Hz by part
- Quick Test Mode (QTM) for manufacturer
- Available timer of 15/30/45/60/90/120/240/480min
- Low cost lead free package: TO-92 or DIP-8 or SOIC-8

Description

Universal timer is a mixed signal CMOS IC designed for a fixed timer to drive external SCR to implement safety power control. It is applied to 120V/240V and 50/60Hz AC power supply. It can automatically shut-off load in order to prevent undesired conditions from the system. Internal timer can present several kinds of different time: 15mins, 30mins, 45mins, 1hr, 1.5hrs, 2hrs, 4hrs and 8hrs, which is decided by part number.

Applications

- Universal Timer Controller

Pin Configuration

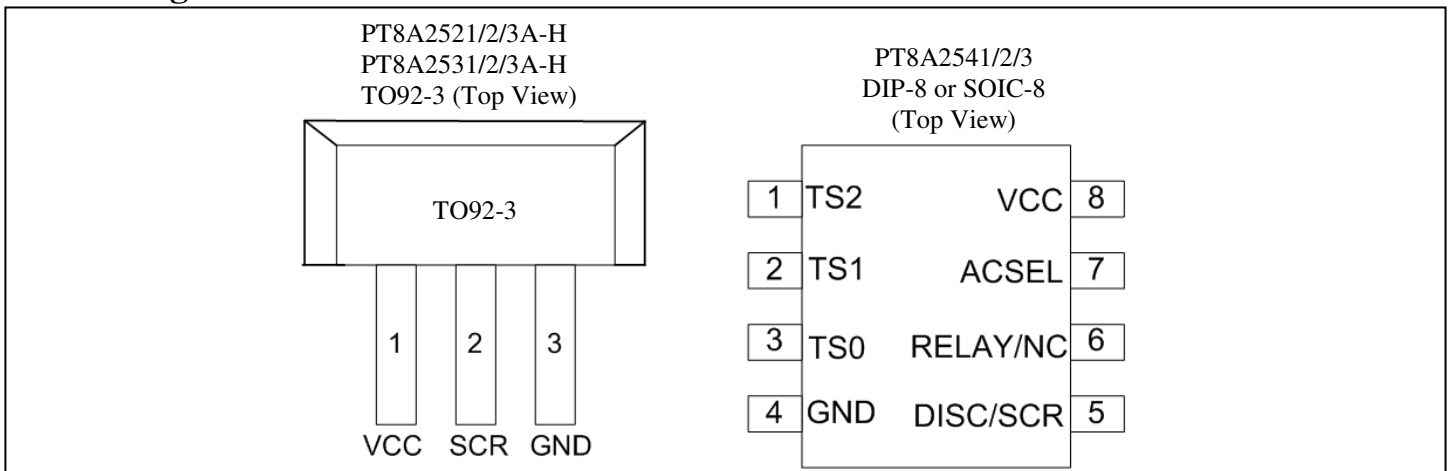

Pin Description

PT8A2521/2/3A-H, PT8A2531/2/3A-H

Pin Name	Pin No	I/O	Pin Description
VCC	1	-	Power supply
SCR	2	I/O	SCR output and button input, high active
GND	3	-	Ground

PT8A2541/2/3

Pin Name	Pin No.	I/O	Pin Description
TS2	1	I	Timer selection pins(TS2 TS1 TS0 from 000~111) 000: 15m, 001: 30m, 010: 45m, 011: 60m, 100: 90m, 101: 120m,110: 240m,111: 480m Default 011 by TS2 internal pull down, TS1&TS0 internal pull up.
TS1	2	I	
TS0	3	I	
GND	4	-	Ground.
SCR	5	I/O	SCR output and button input, high active.
NC	6	I/O	No connection.
ACSEL	7	I	50/60Hz selection pin: default is 60Hz by internal pull down; connecting to VCC is 50Hz.
VCC	8	-	Power supply.

Maximum Ratings

Storage Temperature	-40°C to +125°C
Supply Voltage to Ground Potential (Input & V _{CC} Only).....	-0.5V to V _{CC} +0.5V
Supply Voltage to Ground Potential (Outputs & D/O Only).....	-0.5V to V _{CC} +0.5V
DC Input Voltage	-0.5V to V _{CC} +0.5V
DC Output Current	20mA
Power Dissipation	500mW

Note:

Stresses greater than those listed under MAXIMUM RATINGS may cause permanent damage to the device. This is a stress rating only and functional operation of the device at these or any other conditions above those indicated in the operational sections of this specification is not implied. Exposure to absolute maximum rating conditions for extended periods may affect reliability.

Recommended operation conditions

Symbol	Parameter	Min	Typ	Max	Unit
V _{CC}	Operating Voltage	4.2	4.7	5.2	V
T _A	Operating temperature	0	25	85	°C

Electrical Characteristics

Sym	Parameter	Test Conditions		Min	Typ	Max	Unit
		V _{CC}	Conditions				
V _{CC}	Shunt Regulator output voltage	-	I _{CC} = 1mA	4.2	4.7	5.2	V
V _{TH1}	Input high threshold(SCR)	5V	-	3.6	4	4.4	V
V _{TH2}	Input low threshold(SCR)	5V	-	0.3	0.65	1.0	V
I _{OH}	Output Source Current (SCR)	5V	V _{OHI} = 2.5V	-0.2	-0.3	-0.4	mA
I _{OL}	Output Sink Current (SCR)	5V	V _{OLI} = 0.5V	6	12	24	μA
I _{CC}	Power supply current	4.0V	-	-	-	0.5	mA
F _{OSC}	Frequency of internal oscillator	5V	-	96	128	160	KHz

Block Diagram

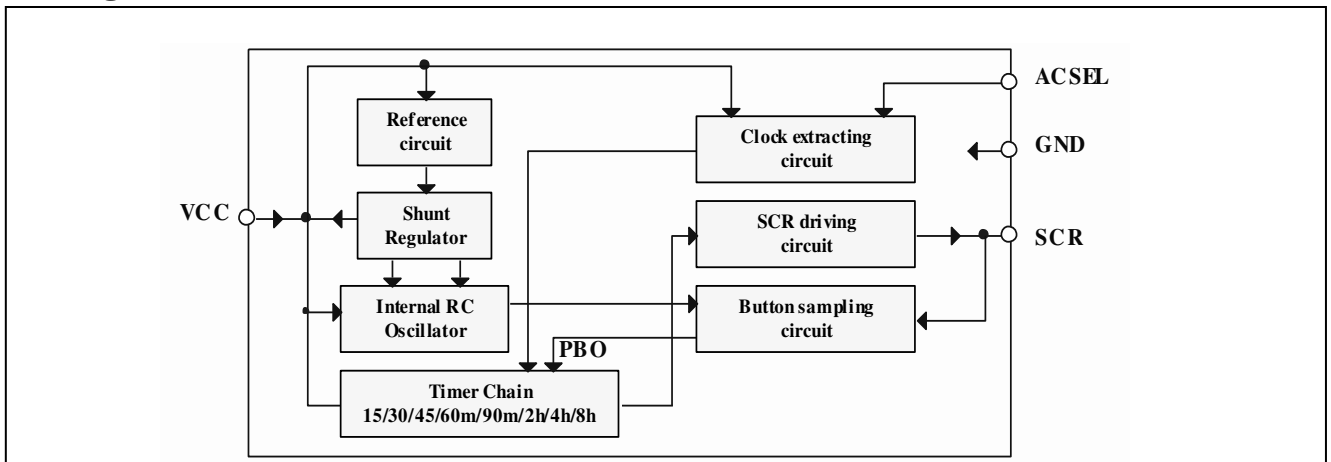

Functional Description (Note: In below description, “RELAY” presents a pin, while “relay” means a device.)

- Reference and Shunt Regulator**
 Reference circuit generates 1.2V VCC-independent and temperature-independent voltage to provide reference voltage for the build-in shunt regulator. The regulator supplies all internal function blocks.
- Clock extracting circuit**
 VCC is not only the power supply pin but also clock source for internal precise timer. With the help of the external circuit, the AC 50/60Hz clock signal can be extracted to be used as timer clock source.
- Internal RC oscillator circuit**
 It is employed to create pulse driving signal for RELAY, it is a completely internal RC oscillator with frequency of about 128KHZ.
- Timer chain**
 Timer chain can be used to generate various timer including 15/30/45/60/90/120/240/480min.
- Button sampling circuit**
 With external buttons, ON/OFF/RESET function can be realized. User can select one button with once ON, once OFF or two buttons to turn ON or OFF separately, also use one button to restart timer.

Button sampling circuit senses button's operation 3 times per 8ms. System will sample the button's operation during first 100ms after power on, if buttons are pressed during this period, then system will start 3s timer to check if the chip will enter into quick test mode (see test mode section). If the related button is pressed over 3s just after power on, chip will enter quick test mode as soon as the button is released. If buttons are not pressed during first 100ms, system will operate normally.

- SCR driving circuit**
 System outputs high to drive high sensitive SCR.
- Quick Test Mode(QTM)**
 In order to make the manufacturer's test convenient, quick test mode is designed to speed up the test. QTM can be accessed by pressing button (ON/RESET) over 3s (option 2s) once power on. It can exit automatically after quick test timer is expired, system needs to power on again to come back normal operation after quick test mode. Any button operations will be ignored in QTM.

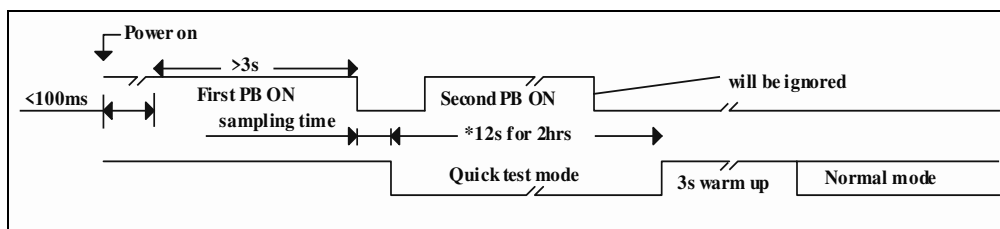

Operation illustration of entering into and exiting Quick test mode

Below table shows the timer in QTM corresponding to real timer.

Table Real timer compared to the timer in QTM

Real timer	15m	30m	45m	60m	90m	120m	240m	480m
Timer in QTM	2s	4s	6s	8s	10s	12s	14s	16s

Application Circuit

Note: SCR is high sensitive SCR which the gate trigger current is about 200uA.

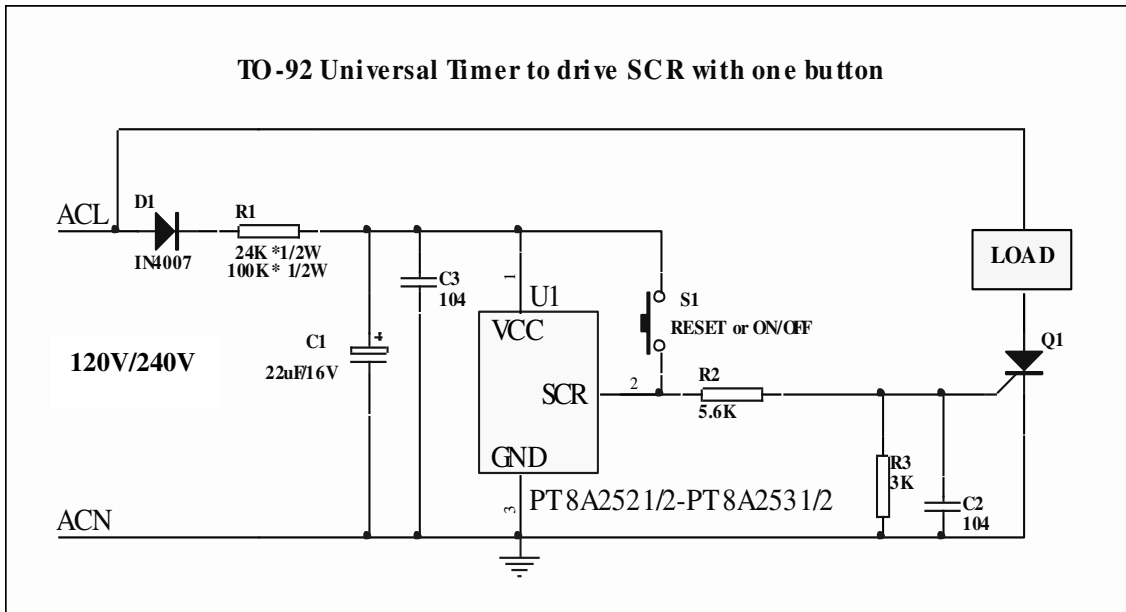

***Note1:** For 120VAC power supply system, R1 value is 24K.

For 240VAC power supply system, R1 value is 100K.

Note2: C1 value range is 22uF to 68uF.

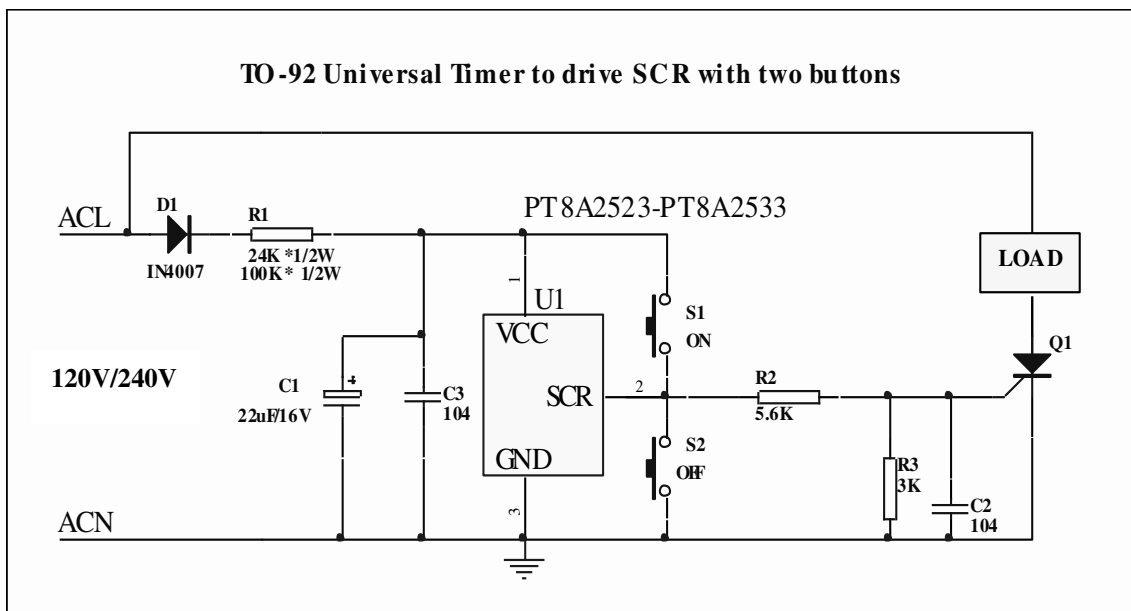

***Note1:** For 120VAC power supply system, R1 value is 24K.

For 240VAC power supply system, R1 value is 100K.

Note2: C1 value range is 22uF to 68uF.

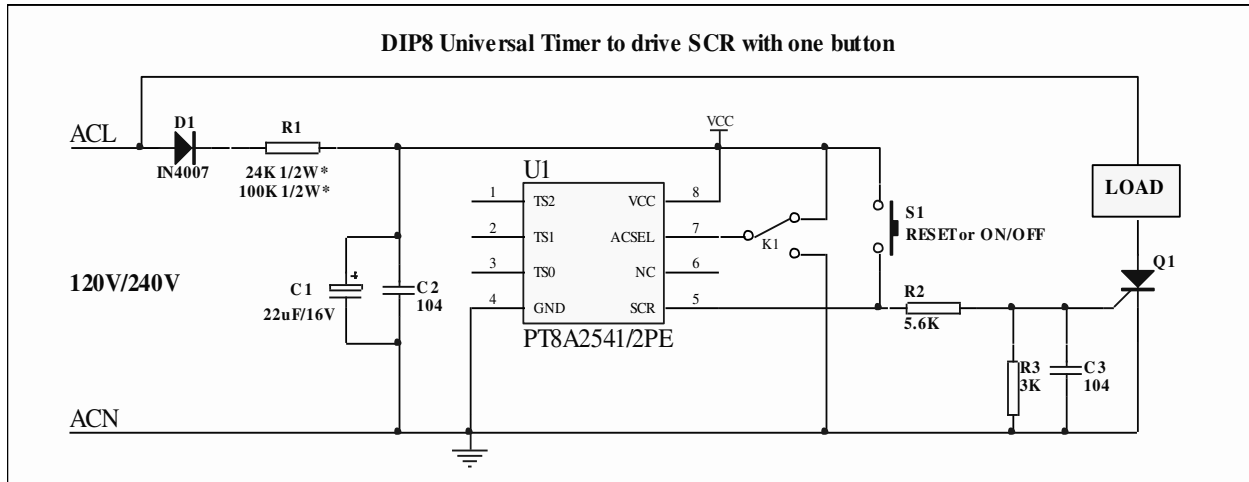

***Note1:** For 120VAC/60Hz power supply system, R1 value is 24K, ACSEL is connected to GND or floating.
 For 240VAC/50Hz power supply system, R1 value is 100K, ACSEL is connected to VCC.

***Note2:** TS0, TS1 and TS2 are floating, the timer time out is 60 minutes.

Note3: C1 value range is 22uF to 68uF.

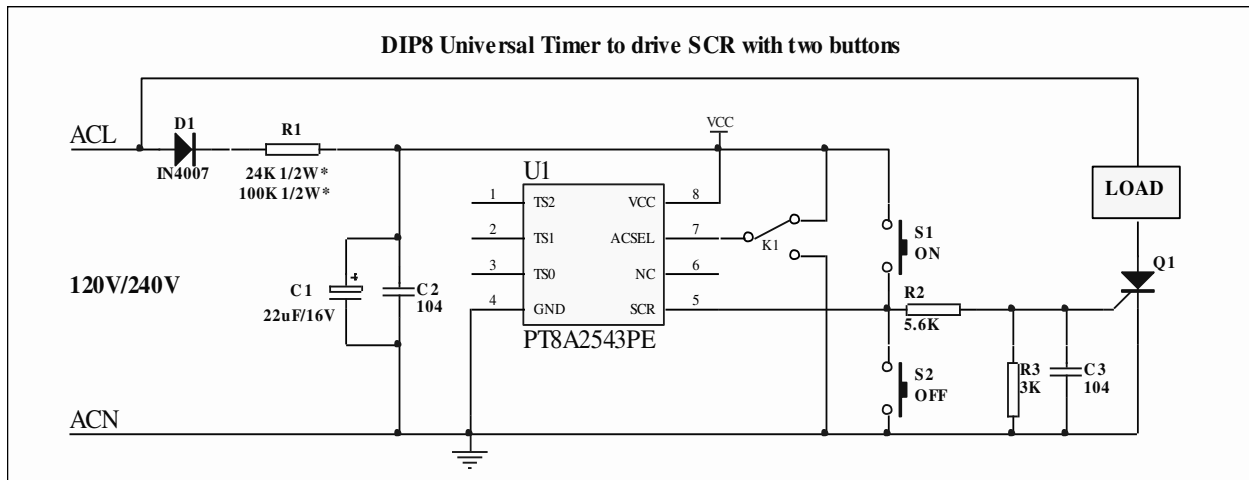

***Note1:** For 120VAC/60Hz power supply system, R1 value is 24K, ACSEL is connected to GND or floating.
 For 240VAC/50Hz power supply system, R1 value is 100K, ACSEL is connected to VCC.

***Note2:** TS0, TS1 and TS2 are floating, the timer time out is 60 minutes.

Note3: C1 value range is 22uF to 68uF.

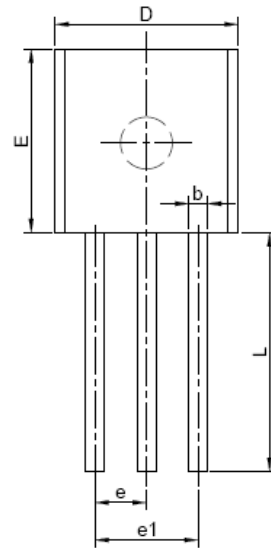
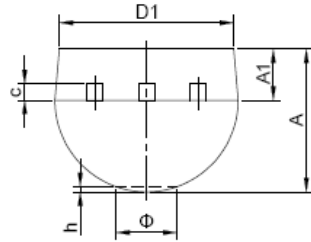
Mechanical Information
TO92-3L

PKG. DIMENSIONS(MM)		
SYMBOL	Min	Max
A	3.30	3.70
A1	1.10	1.40
b	0.38	0.65
c	0.36	0.51
D	4.30	4.70
D1	3.43	
E	4.30	4.70
e	1.27 TYP	
e1	2.44	2.64
L	14.10	14.50
Φ		1.80
h	0.00	0.38

Note:



DATE: 06/18/13

DESCRIPTION: 3-Pin, T092

PACKAGE CODE: NB (NB3)

DOCUMENT CONTROL #: PD-2149

REVISION: --

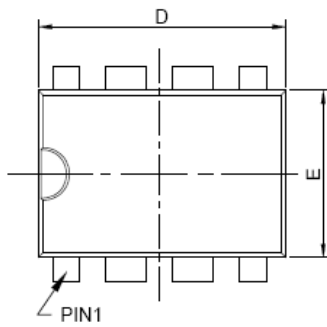
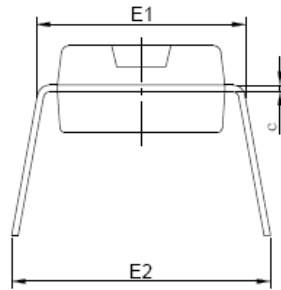
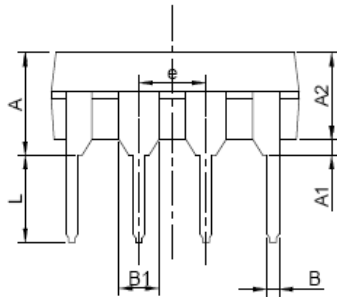
DIP-8L

PKG. DIMENSIONS(MM)		
SYMBOL	Min	Max
A	3.71	4.31
A1	0.51	
A2	3.20	3.80
B	0.38	0.57
B1	1.52 BSC	
c	0.20	0.36
D	9.00	9.40
E	6.20	6.80
E1	7.32	7.92
e	2.54 BSC	
L	3.00	3.60
E2	8.40	9.00

Notes:

1. Refer JEDEC MS-001D/BA



DATE: 06/14/13

DESCRIPTION: 8-Pin, Dual InLine Plastic, DIP

PACKAGE CODE: P (P8)

DOCUMENT CONTROL#: PD-2134

REVISION: --

SOIC-8L
DOCUMENT CONTROL NO.
 PD - 1001

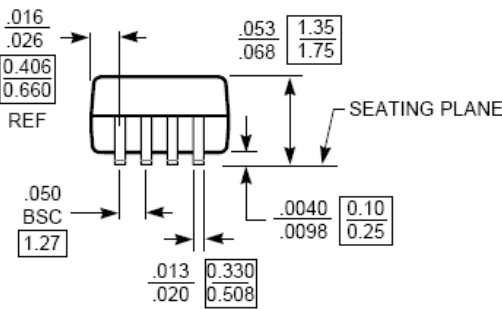
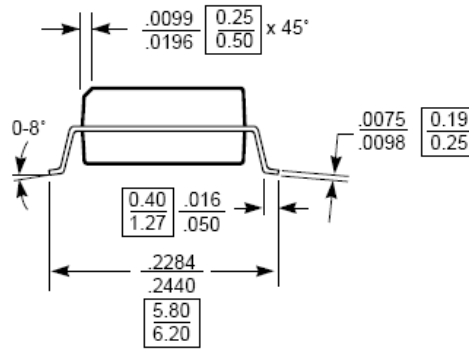
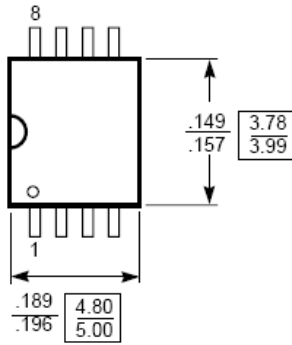
REVISION: E
DATE: 07/06/99

X.XX DENOTES DIMENSIONS
X.XX IN MILLIMETERS

Notes:

- 1) Controlling dimensions in millimeters.
- 2) Ref. JEDEC MS - 012 AA

 Pericom Semiconductor Corporation
 2380 Bering Drive, San Jose, CA 95131
 Tel: (408) 435-0800 • Fax: (408) 435-1100

DESCRIPTION: 8-PIN SOIC (150 MIL WIDE)
PACKAGE CODE: W8

Ordering Information

Ordering No.	Package Code	Package
PT8A2521xNBE*	NB	Lead free TO-92
PT8A2522xNBE*	NB	Lead free TO-92
PT8A2523xNBE*	NB	Lead free TO-92
PT8A2531xNBE*	NB	Lead free TO-92
PT8A2532xNBE*	NB	Lead free TO-92
PT8A2533xNBE*	NB	Lead free TO-92
PT8A2541PE*	P	Lead free DIP-8
PT8A2542PE*	P	Lead free DIP-8
PT8A2543PE*	P	Lead free DIP-8
PT8A2541WE	W	Lead free and Green SOIC-8
PT8A2542WE	W	Lead free and Green SOIC-8
PT8A2543WE*	W	Lead free and Green SOIC-8

Note:

- “x” shows A~H with different Internal Timer, see below Suffix x: Internal Timer table.
- E = Pb-free or Pb-free & Green
- Adding X Suffix= Tape/Reel
- *contact Pericom for availability.

Function Comparison Table

Part No	One/Two key	Button	50/60 Hz	Part No	One/Two key	Button	50/60 Hz
PT8A2521x	One	Reset	50HZ	PT8A2531x	One	Reset	60HZ
PT8A2522x	One	On/Off	50HZ	PT8A2532x	One	On/Off	60HZ
PT8A2523x	Two	On, Off	50HZ	PT8A2533x	Two	On, Off	60HZ

Part No	One/Two key	Button	50/60 Hz	Timer(min)
PT8A2541	One	Reset	Optional	Optional
PT8A2542	One	On/Off	Optional	Optional
PT8A2543	Two	On, Off	Optional	Optional

Suffix x: Internal Timer Table

Suffix	A	B	C	D	E	F	G	H
Internal Timer(min)	15	30	45	60	90	120	240	480

Pericom Semiconductor Corporation • 1-800-435-2336 • www.pericom.com

Pericom reserves the right to make changes to its products or specifications at any time, without notice, in order to improve design or performance and to supply the best possible product. Pericom does not assume any responsibility for use of any circuitry described other than the circuitry embodied in Pericom product. The company makes no representations that circuitry described herein is free from patent infringement or other rights, of Pericom.