

CMRC - SERIES

ASSEMBLY INSTRUCTIONS FOR CABLE MANAGEMENT RING CMRC34, CMRC36, CMRC126

BUL10397
REV. A
PAGE 1 OF 1

ASSEMBLY INSTRUCTIONS: USING SUPPLIED HARDWARE

ASSEMBLY INSTRUCTIONS: FOR 10-32 OR 12-24 HOLES (HARDWARE NOT SUPPLIED)

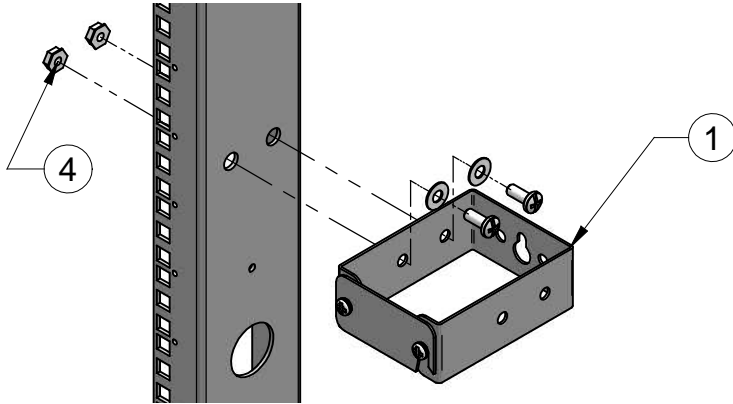

CMRC REAR FLUSH WITH RELAY RACK

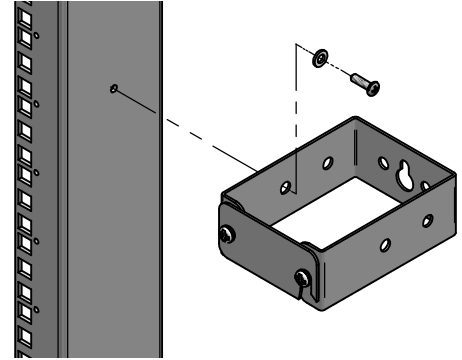

SINGLE SIDE HOLE MOUNTING

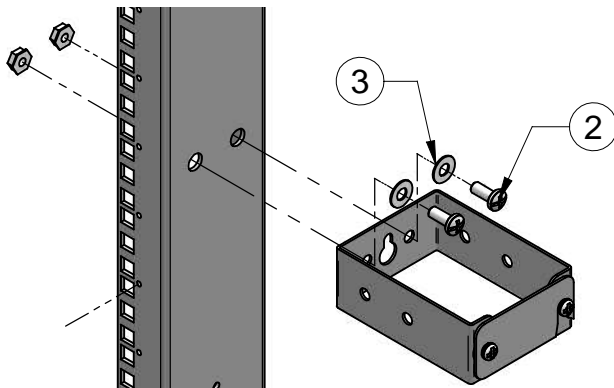

CMRC CENTERED ON RELAY RACK

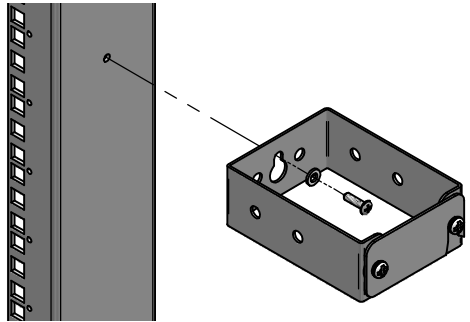

CENTER REAR HOLE MOUNTING

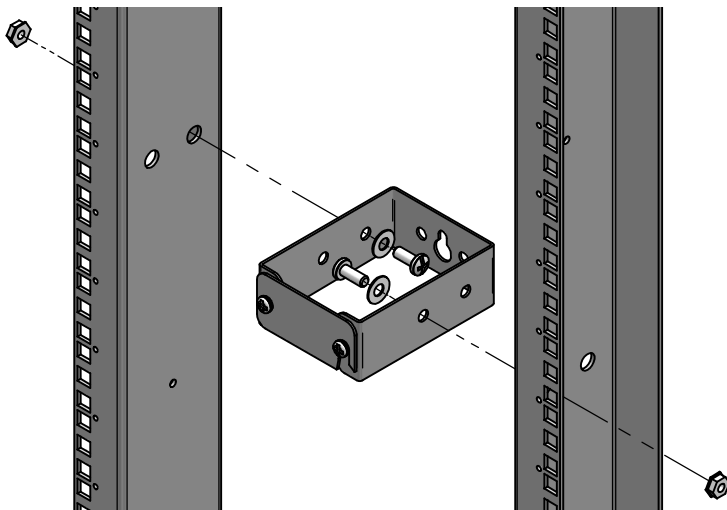

CMRC USED IN GANGING APPLICATION

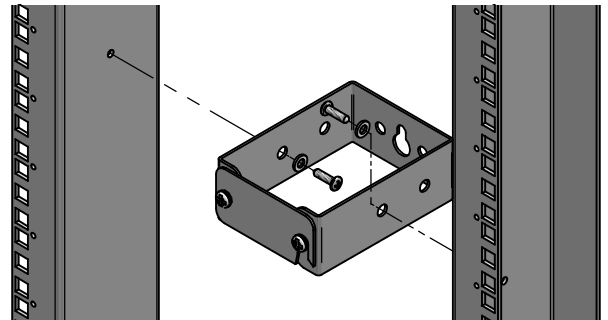

ALTERNATIVE GANGING OPTION

PARTS LIST

ITEM No.	DESCRIPTION	QTY
1	CABLE MANAGEMENT RING	1
2	1/4-20 X 5/8 SCREW	2
3	1/4 FLAT WASHER	2
4	1/4-20 KEP NUT	2

TOOL BOX



Phillips
Screw Driver



Open End
Wrench



**HAMMOND
MANUFACTURING™**
ELECTRONICS GROUP

visit our website @ www.hammondmfg.com