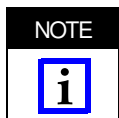

Figure 1

## 1. INTRODUCTION

The 180° Cable Clamp Assembly 1424035-1 is designed to be used in CHAMPOMATOR\* 2.5 Bench Terminating Machine 762734-[ ]. The machine must be equipped with a clamp solenoid valve (shown in Figure 4) and a controller having software at Rev. 3.03.05 or later. To use the machine without these requirements, use 180° Cable Clamp Assembly 768830-1 and follow the instructions packaged with that cable clamp.

The cable clamp permits the machine to apply discrete-wire jacketed cable to AMPLIMITE\* .050 Series connectors, AMPLIMITE HDE connectors, CHAMP\* connectors, and AMPMODU\* MT connectors.



*All dimensions on this sheet are in millimeters [with inch equivalents in brackets]. Figures and illustrations are for identification only and are not drawn to scale.*

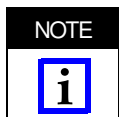

*Make sure to retain all material in the bench terminating machine documentation package for reference. For detailed information on the operation of the machine, refer to Customer Manual 409-5839 which is supplied with the machine.*

Reasons for reissue of this instruction sheet are provided in Section 8, REVISION SUMMARY.

## 2. DESCRIPTION (Figure 1)

The cable clamp is capable of being adjusted to give a 1805 cable breakout, and it can also be offset for the angle-exit option when applying AMPLIMITE .050 Series connectors with the machine.

During operation, the operator places the cable into the cable clamp, and places the wires in the wire holder, which holds the cable wires in place during the termination process, helping to keep the loose wires out of the operator's way.

As the wires are terminated, the clamp follows the cam track and moves to provide the desired breakout length. The clamp eventually bottoms in the cam track, determining the position of the cable with respect to the connector.

After all terminations have been completed, the machine moves to the forward home position. At this time, the operator unclamps the cable, then presses the machine's "INDEX" and "LOAD" buttons. The machine carriage and cable clamp then move to their respective home positions, permitting the operator to remove the completed cable assembly from the machine.



*Make sure that the cable assembly does not get caught on the cable clamp, or damage to the cable assembly could result. This is particularly important when processing the second-end connector on a short cable assembly.*

### 3. INSTALLATION



*It is necessary to open or remove machine covers to perform the following procedure. Be sure to replace ALL covers BEFORE operating the machine.*

The cable clamp's pivot bracket attaches to the machine carriage, and the cam track assembly mounts to the machine's base block assembly. To mount the clamp:

1. Turn off the machine's air supply by disengaging the air supply at the back of the machine.
2. Turn off the machine's electrical functions by switching the rocker switch on the back of the machine's control module.



*DO NOT make adjustments to the machine or the cable clamp while the machine is operational. Make sure to disable the machine to prevent it from moving while adjustments are being made.*

3. Attach the pivot bracket to the back of the machine carriage with the No. 10-32 screws provided. Refer to Figure 2. Using a 5/32-in. hex wrench, tighten the screws.

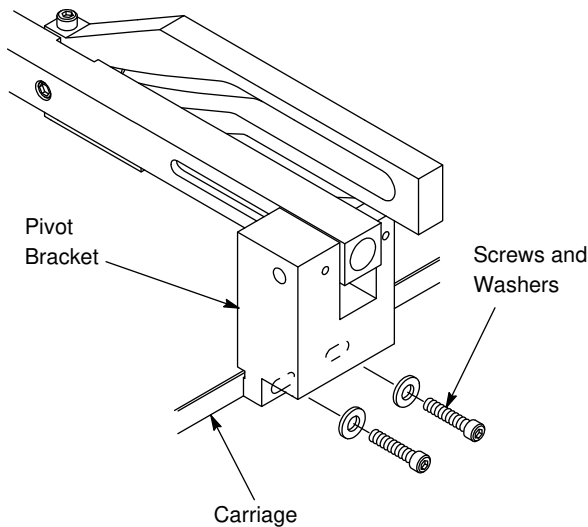
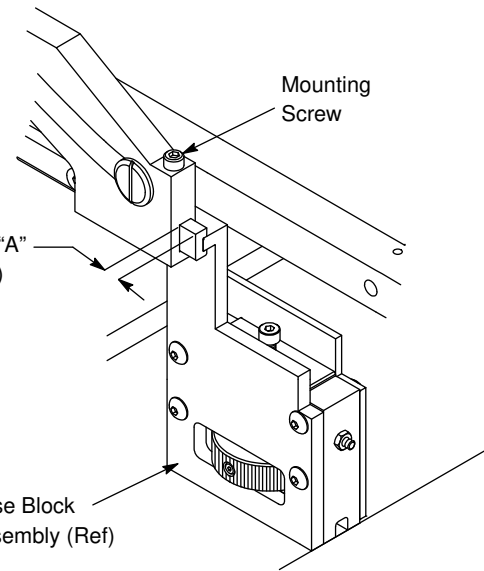

Figure 2

4. Slide the bottom of the cam track assembly onto the rack portion of the base block assembly. Make sure that the cam track assembly mounting screw is raised to allow the cam track to slide.
5. Adjust the position of the cam track assembly to Dimension A shown in Figure 3 to ensure that the cable is located for either straight exit or angle exit.
6. Using a 5/32-in. hex wrench, tighten the mounting screw to secure the cam track.



CONNECTOR		DIMENSION "A"	
TYPE	SIZE	STRAIGHT EXIT	ANGLE EXIT
AMPLIMITE .050	20	2.54 [.100]	1.27 [.050]
	40	5.58 [.220]	13.97 [.550]
	50	8.38 [.330]	15.24 [.600]
	68	13.20 [.520]	26.67 [1.050]
	80	17.01 [.670]	34.29 [1.350]
	100	23.62 [.930]	46.99 [1.850]
120	33.52 [1.320]	55.88 [2.200]	
AMPLIMITE HDE	All	18.54 [.730]	---
CHAMP	All		

Figure 3

7. On the machine, plug the air hose from the clamp solenoid valve (see Figure 4) onto the fitting of the cable clamp (refer to Figure 1).
8. Turn on the air to the machine, and inspect the cable clamp for air leaks.

### 4. TOOLING ADJUSTMENTS



*To avoid personal injury, DISCONNECT air and electric power before making adjustments to the machine or cable clamp. DO NOT make adjustments while the machine is operational.*

#### 4.1. Cable Clamp Position

The position of the cable clamp can be adjusted to vary the cable exit position relative to the connector. To adjust this position, refer to Figure 3, and proceed as follows:

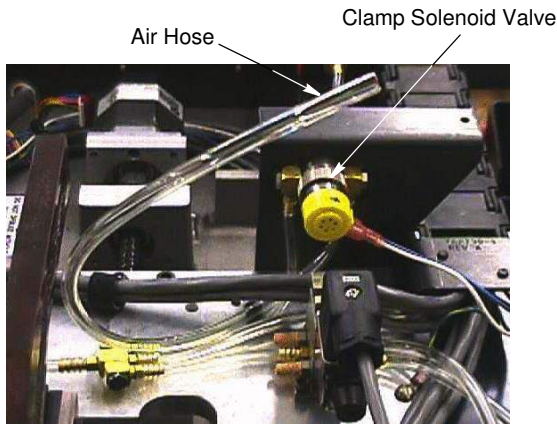

Figure 4

1. Return the machine to the LOAD position.
2. Using a 5/32-in. hex wrench, loosen the cam track mounting screw.
3. Adjust the cam track to Dimension A shown in Figure 3 or as desired.
4. Tighten the cam track mounting screw.

4.2. Jaw

The jaw can be adjusted two steps to the right by removing the four mounting screws and flipping the clamp bracket over or upside down.

4.3. Cable Breakout Indicator

1. Loosen the cable breakout indicator locking screw.
2. Lower the cable breakout indicator to shorten the cable breakout dress. Raise the cable breakout indicator to increase the cable breakout length.
3. Secure the cable breakout indicator locking screw.



**DO NOT OVERTIGHTEN.** The locking screw is threaded into aluminum. Overtightening will strip the threads in the jaw.

5. MAINTENANCE

Lubricate the cam track with a good, quality, light machine oil to ensure optimum service. Wipe off any excess oil.

6. REPLACEMENT PARTS

Figure 5 lists the items that are recommended as customer-replaceable parts. These items should be inspected regularly. Customer-replaceable parts should be stocked to prevent machine downtime in the event that they require replacement.

Order replacement parts through your TE Connectivity Representative, or call 1-800-526-5142, or send a facsimile of your purchase order to 1-717-986-7605, or write to:

CUSTOMER SERVICE (038-035)  
 TYCO ELECTRONICS CORPORATION  
 PO BOX 3608  
 HARRISBURG PA 17105-3608

PART NUMBER	DESCRIPTION	QTY PER ASSY
230932-1	Bearing, Drawn Cup	1
763596-1	Wire Holder	1
980311-3	Air-Activated Cylinder	1
5-22284-6	Compression Spring	3
761204-1	Wire Clamp	1
994916-1	Clamp Solenoid Valve	1

Figure 5

7. OTHER CABLE CLAMPS

Cable clamps not supplied with the specific CHAMPOMATOR 2.5 bench terminating machine are required to terminate other product lines on the machine. For information on these cable clamps, contact your representative.

8. REVISION SUMMARY

- New logo