

THIS DRAWING IS UNPUBLISHED. RELEASED FOR PUBLICATION
 © COPYRIGHT BY TYCO ELECTRONICS CORPORATION. ALL RIGHTS RESERVED.

LOC	DIST	REVISIONS			
P	LTR	DESCRIPTION	DATE	DWN	APVD
	E	REV PER EC 0S12-0302-05	12DEC05	BC	GS
	E1	REVISED PER ECO-09-022908	06OCT09	KK	AEG
	F	ECR-10-019054	15SEP10	DP	MQW

- 1 POWER PIN BASE: BRASS.
CONTACT SPRING: BERYLLIUM COPPER.
RETENTION RING: BERYLLIUM COPPER.
- 2 POWER PIN BASE: 2.54µm MIN TIN LEAD OVER 1.27µm MIN NICKEL.
RETENTION RING: 1.27µm MIN NICKEL OVER 2.03µm MAX COPPER.
- 3 POWER PIN SOCKET: 0.76µm MIN GOLD OVER 1.27µm MIN NICKEL.
- 4 POWER PIN SOCKET: 1.27µm MIN GOLD OVER 1.27µm MIN NICKEL.
- 5. RECOMMENDED PLATED THROUGH HOLE DIMENSIONS: DRILLED HOLE IS
ø3.19-3.25, CU THICKNESS 25µm MIN, SnPb THICKNESS
5µm MIN FOR A FINISHED HOLE SIZE OF ø3.02-3.20.
- 6 OBSOLETE PARTS: OBSOLETE CIS STREAMLINING PER D.RENAUD/D.SINISI

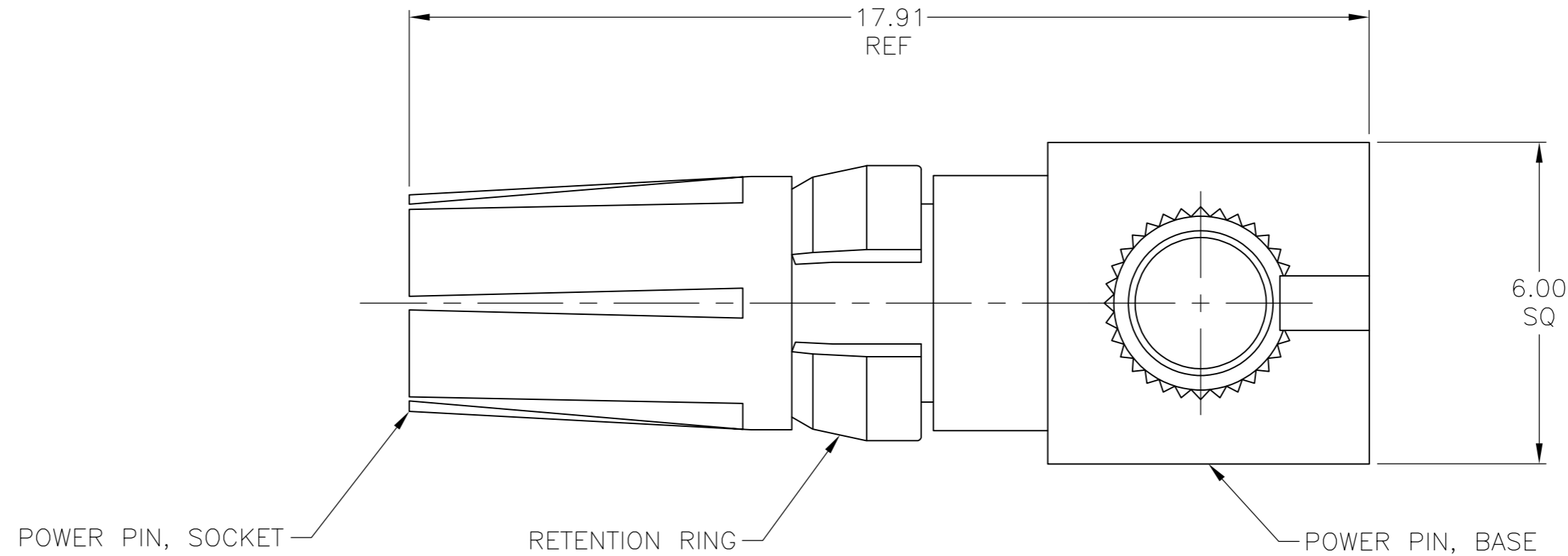
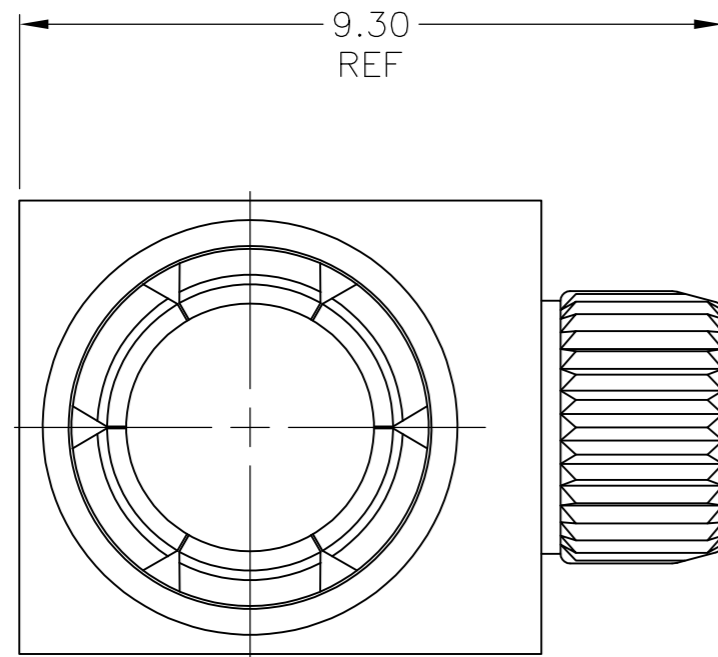

POWER PIN, SOCKET

RETENTION RING

POWER PIN, BASE

6	OBSOLETE	2 4	646857-2
		2 3	646857-1
	FINISH		PART NUMBER

THIS DRAWING IS A CONTROLLED DOCUMENT.		DWN L.BRINER 11/30/00	Tyco Electronics Corporation Harrisburg, PA 17105-3608	
DIMENSIONS: mm		CHK R.PATTERSON 11/30/00	NAME ASSEMBLY, POWER CONTACT, Z-PACK 2mm HM, TYPE M, FEMALE 90 DEG, PRINTED CIRCUIT BOARD MOUNT	
TOLERANCES UNLESS OTHERWISE SPECIFIED:		APVD R.PATTERSON 11/30/00	SIZE A2	CAGE CODE 00779
0-PLG ±		PRODUCT SPEC	DRAWING NO C=646857	RESTRICTED TO
1-PLG ±		APPLICATION SPEC	SCALE 10:1	SHEET 1 of 1
2-PLG ± 0.13 ±0.2		WEIGHT -	REV F	
3-PLG ±		CUSTOMER DRAWING		
4-PLG ±				
ANGLES ±				
FINISH				