

REV	DATE	ECN NO.	APPVD BY	REL BY
G	12-28-98	UM9-0238 UPDATED REVISION	FVW	
H	11-3-99	UM2000-0319 REFORMATTED		

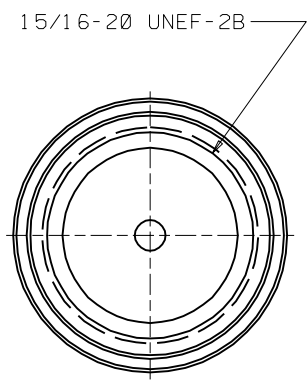
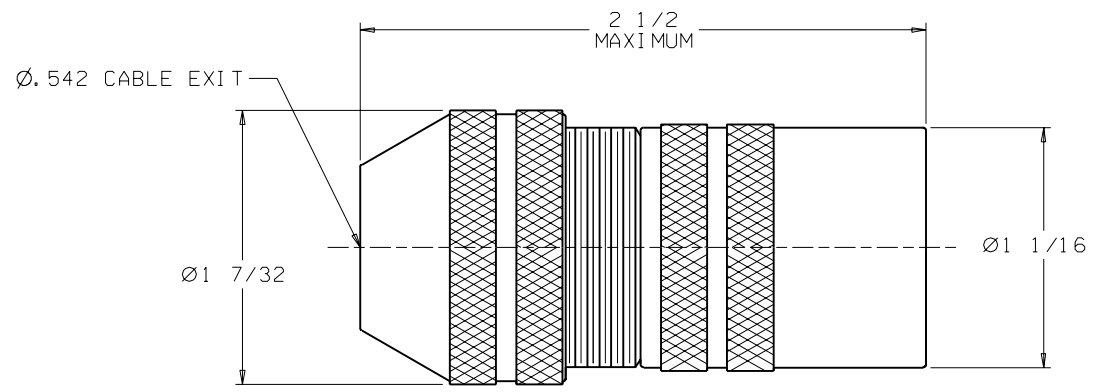

1.0 RECOGNIZED AGENCY APPROVALS:

CSA CERTIFICATION AND UL RECOGNITION IS PLANNED.

2.0 MECHANICAL SPECIFICATIONS:

MATERIAL:

BACKSHELL, COMPRESSION NUT, AND CONE: GLASS REINFORCED NYLON  
SEALS: RUBBER

3.0 CABLE SECUREMENT

3.1 EACH CABLE BACKSHELL WHEN ASSEMBLED WITH THE SMALLEST DIAMETER CABLE IN THE SPECIFIED RANGE WILL BE CAPABLE OF SURVIVING A DEAD WEIGHT PULL OF 35 LBS. FOR 1 MINUTE PER UL-STD-514.

3.2 EACH CABLE BACKSHELL WHEN ASSEMBLED WITH MIDPOINT OF THE RANGE CABLE WILL BE CAPABLE OF A DEAD WEIGHT PULL OF 50 LBS. FOR 1 MINUTE PER UL-STD-514.

4.0 ENVIRONMENTAL SPECIFICATIONS:

4.1 RAIN TIGHT: THE BACKSHELL WHEN ASSEMBLED WITH THE PROPER CABLE AND CONNECTOR WILL MEET THE RAIN TEST REQUIREMENT DEFINED IN UL-STD-514.

TEMPERATURE RATING: -40 DEGREES C TO +90 DEGREES C.

4.2 SALT SPRAY: 500 HOUR SALT SPRAY PER MIL-STD-1344 METHOD 1001.

<b>QUALITY SYMBOLS</b> MAJOR = CRITICAL = SPC =	<b>UNLESS SPECIFIED:</b> ALL DIMENSIONS IN INCHES  <b>GENERAL TOLERANCES:</b> 3 PLACE ±.005 2 PLACE ±.01 ANGULAR ±2°	<b>SCALE</b> 2:1  <b>DWG SIZE</b> B	<b>THIRD ANGLE PROJECTION</b>	<b>REVISE ON CAD ONLY</b>	
	<b>Uti-Mate CAGE CODE</b> 58967	<b>SCALE</b> 2:1  <b>DWG SIZE</b> B	<b>DRAWN BY &amp; DATE</b> CLC 8-18-92  <b>CHECKED BY &amp; DATE</b> DW 8-18-92  <b>APPROVED BY &amp; DATE</b> DW 8-18-92	<b>TITLE:</b> CABLE BACKSHELL, 15/16"-20 UNEF, .300/.525	<b>MOLEX INCORPORATED</b> Orange, CA 92868
		<b>PART NO.</b> 849700010	<b>DRAWING NO.</b> SD-84970-0010	<b>92868</b> <b>SHEET NO.</b> 1 OF 1	
		THIS DRAWING CONTAINS INFORMATION THAT IS PROPRIETARY TO MOLEX INCORPORATED AND SHOULD NOT BE USED WITHOUT WRITTEN PERMISSION.			<b>REV</b> H