

DISTRIBUTORS/REP OTHERS \_\_\_\_\_

Issue No : 20100111 \_\_\_\_\_

Date of issue : Feb 02,2010 \_\_\_\_\_

Classification :  New  Change

## PRODUCT SPECIFICATION FOR APPROVAL

Product Description : LIGHT TOUCH SWITCH

Product Part Number: \_\_\_\_\_ (Panasonic Part Number : EVPAFGB65 )

Country of Origin : Japan (It is indicated in the packing label with English)

Applications : It depends on 1.2"Application Limits"

\*If you approval this specification, please fill in and sign the below and return 1 copy to us.

Approval No :	
Approval Date:	
Executed by :	
	_____ (Signature)
Title :	
Dept. :	

Electromechanical Components Business Unit  
Panasonic Electronic Devices Co., Ltd.

1006 Kadoma, Osaka, Japan

Phone : +81-6-6908-7304 (Direct)

Prepared by : Panasonic  
Electronic Devices Japan Co., Ltd.  
Tsuyama Division  
Engineering Section

Contact Person : *Y. Muto*  
Signature \_\_\_\_\_  
Name (Print) Y.Muto  
Title

Authorized by : *Y. Yanai*  
Signature \_\_\_\_\_  
Name (Print) Y.YANAI  
Title Team leader of Engineering

**Panasonic**

Classification	SPECIFICATION	Issue No. 20100111
Part Name LIGHT TOUCH SWITCH	Part No. EVPAFGB65	1/13
<p>1. Notification Items</p> <p>1.1 Law and the regulation which are applied</p> <p>①This product has not been manufactured with ozone depleting chemical controlled under the Montreal Protocol.</p> <p>②This product complies with the RoHS Directive (Restriction of the use of certain Hazardous Substance) in electrical and electronic equipment (DIRECTIVE 2002/95/EC).</p> <p>③All the materials used in this part are registered material under the Law Concerning the Examination and Regulation of Manufacture etc. or Chemical Substances.</p> <p>④Permission must be obtained from the Japanese government if the product that is subject to the "Foreign Exchange and Foreign Trade Law" is to be exported or taken out of Japan.</p> <p>1.2 Application Limits</p> <p>This product was designed and manufactured for general electronics devices household appliances, office equipment, data and communication equipment.</p> <p>For the following applications in which high reliability and safety are required, or for the applications in which the failure or malfunction of the products may directly jeopardize life or cause threat of personal asset, please contact us beforehand.</p> <p>•Aircraft and aerospace equipment, anti-disaster or anti-crime equipment, medical equipment, transport equipment(automotives, trains, boat etc), high public information processing devices or the other equipments or devices that are equivalent to the above mentioned.</p> <p>1.3 Handling of approval specification</p> <ul style="list-style-type: none"> <li>• Writings in this specification form are subject to change through precautions.</li> <li>• This specification form specify this item only. Please perform your approval test in the actual application conditions beforehand.</li> </ul> <p>1.4 Manufacturing Sites</p> <p>① The country of manufacture : Japan Panasonic Electronic Devices Japan Co., Ltd.</p> <p>2. Summary</p> <p>2.1 This specifications applies to the following types of switch. Push-ON type S.P.S.T</p> <p>2.2 This specifications is a constituent document of contract for business concluded between your company and Panasonic Corporation.</p> <p>2.3 Items not particularly specified in this specifications shall be in conformance with JIS Standards.</p>		

Classification	SPECIFICATION	Issue No. 20100111
Part Name LIGHT TOUCH SWITCH	Part No. EVPAFGB65	2/13

3. Dimension • Marking • Circuit diagram

Date code are indicated in the product.

General dimension tolerance:  $\pm 0.1$

( ) dimensions are reference dimensions.

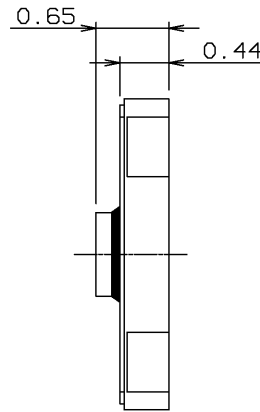
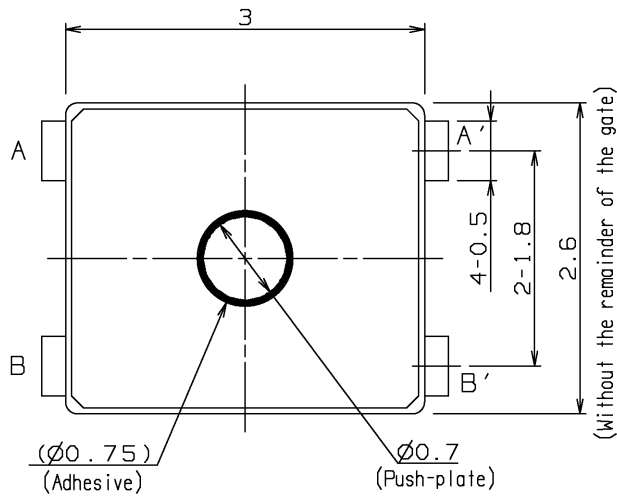

Piece weight : about 0.008g

Solder thickness  $t = 0.12 \pm 0.02$

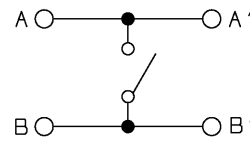

Circuit diagram

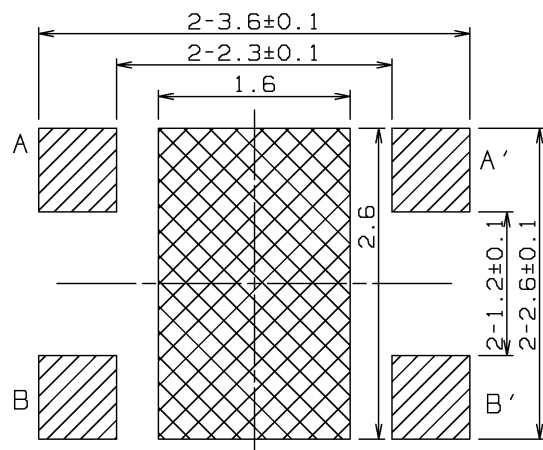
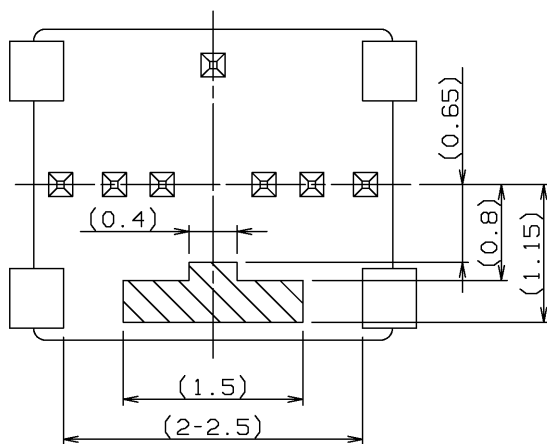
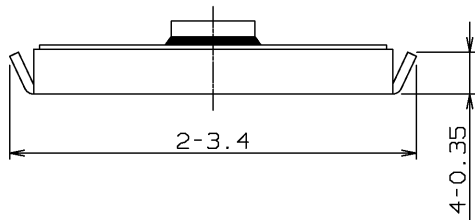

P.W.B. piercing diagram

Part of A-A' terminal is exposed at area.  
Any land pattern or vias shall not be provided at area.

Classification	SPECIFICATION	Issue No. 20100111
Part Name LIGHT TOUCH SWITCH	Part No. EVPAFGB65	3/13

4. General specification

4.1 Switch rating DC 15 V 20 mA(max.) DC 2V 10 μA(min.)

4.2 Operation temperature range -40 °C ~ +85 °C

4.3 Preservative temperature range  
 Single condition : -40~+85 °C  
 Taping condition : -20~+60 °C

4.4 Standard conditions

Unless otherwise specified, the test and measurements shall be carried out as follows.

Ambient temperature : 5~35 °C

Relative humidity : 45~85 %

Air pressure : 86~106 kPa

However, if doubt arises on the decision based on the measured values under the above-mentioned conditions, the following conditions shall be employed.

Ambient temperature : 20 ± 2 °C

Relative humidity : 65 ± 5 %

Air pressure : 86~106 kPa

5. Performance

5.1 Electrical characteristics

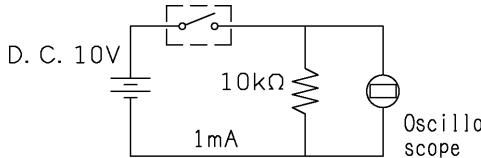
No.	ITEM	TEST CONDITION	PERFORMANCE
5.1.1	Contact resistance	Push force : {Operation force} × 2 Measurement tool : Contact resistance meter (Capable of 10 μA ~ 10 mA)	500 mΩ max.
5.1.2	Insulation resistance	DC 100 V (Between terminals)	50 MΩ min.
5.1.3	Withstand voltage	AC 250 V for 1 minute. (Between terminals)	No insulation destruction
5.1.4	Bouncing	Operation speed : 3~4 times/s   Switch Bouncing Test Circuit	ON 10 ms max.  OFF 10 ms max.

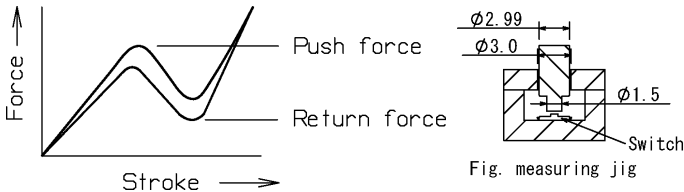
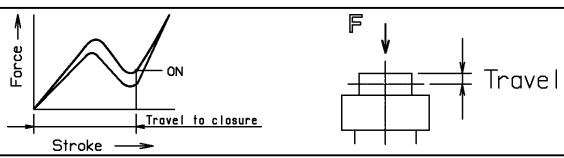
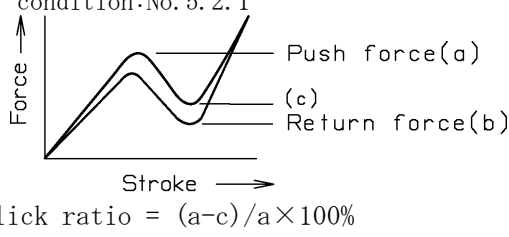
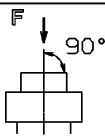
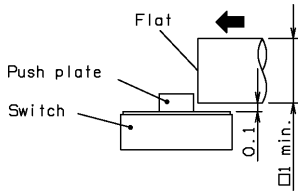
Classification		SPECIFICATION		Issue No.
Part Name LIGHT TOUCH SWITCH		Part No. EVPAFGB65		20100111
				4/13
5.2 Mechanical characteristics				
No.	ITEM	TEST CONDITION	PERFORMANCE	
5.2.1	Operation force	<p>Operation feeling shall be measured after 3 times pre-operations. Pre-operation condition:3 times, 1mm/s by 3N Measurement speed:0.5mm/s</p> 	<p>Push force</p> $1.6^{+0.5}_{-0.5}$ N	<p>Return force</p> <p>0.1 N min.</p>
5.2.2	Travel to closure		$0.15^{+0.10}_{-0.10}$ mm	
5.2.3	Click ratio	<p>Measurement condition:No.5.2.1</p>  <p>Click ratio = <math>(a-c)/a \times 100\%</math></p>	<p>Click ratio</p> <p>30% min.</p> <p>(before reflow soldering)</p>	
5.2.4	Push strength	<p>50 N for 15 sec.</p> 	<p>No damage</p> <p>(Electrical and mechanical)</p>	
5.2.5	Side push strength	<p>3 N for 15 sec.</p> <p>Initial product with 2 times reflow. (Reflow condition: see 6.1)</p> 	<p>No damage</p> <p>(Electrical and mechanical)</p>	
5.2.6	Vibration test	<ol style="list-style-type: none"> <li>1) Amplitude : 1.5 mm</li> <li>2) Sweep rate : 10-55-10Hz for 1 minute</li> <li>3) Sweep method : Logarithmic frequency sweep rate</li> <li>4) Vibration direction : X,Y,Z(3 directions)</li> <li>5) Time : Each direction 2 hours (Total 6 hours)</li> </ol>		<p>No.5.1 and 5.2.1 to 5.2.2 shall be satisfied.</p>
5.2.7	Soldering heat test	<p>Mount the switch on P.W.B by adhesive.</p> <ol style="list-style-type: none"> <li>1) Reflow process 2 times. (Refer to section 6.1)</li> <li>2) Standard conditions after test : 1 hours</li> </ol>		<p>Contact resistance 500 mΩ max.</p> <p>No.5.1.2 to 5.1.4 and No.5.2.1 to 5.2.2 shall be satisfied.</p>
5.2.8	Solderbility	<p>After spreading flux, the terminal is immersed in solder with following condition.</p> <p>Solder ber : M705/Sn-3.0Ag-0.5Cu (Senju Metal Indusry Co.,Ltd.)</p> <p>Flux : CF-110VH-2A (tamura kaken)</p> <p>Soldering temperture : 260±5°C</p> <p>Soldering time : 2±0.5 sec.</p>		<p>95% or more of surface area(Excluding ruptured surface)where is immersed in solder shall be covered by new solder.</p>

Classification	SPECIFICATION		Issue No. 20100111
Part Name LIGHT TOUCH SWITCH	Part No. EVPAFGB65		5/13

### 5.3 Climatic characteristics

No.	ITEM	TEST CONDITION	PERFORMANCE
5.3.1	Cold test	1) Temperature : $-40\pm 2\text{ }^{\circ}\text{C}$ 2) Duration of test : 500 h 3) Take off a drop water. 4) Standard conditions after test : 1 h	Contact resistance 1000 m $\Omega$ max. No. 5.1.2 to 5.1.4 and No. 5.2.1 to 5.2.2 shall be satisfied.
5.3.2	Heat test	1) Temperature : $85\pm 2\text{ }^{\circ}\text{C}$ 2) Duration of test : 500 h 3) Standard conditions after test : 1 h	Contact resistance 1000 m $\Omega$ max. No. 5.1.2 to 5.1.4 and No. 5.2.1 to 5.2.2 shall be satisfied.
5.3.3	Heat shock test	1) Test cycles : 20 cycles 2) Standard conditions after test : 1 h <div style="text-align: center;"> </div>	Contact resistance 1000 m $\Omega$ max. No. 5.1.2 to 5.1.4 and No. 5.2.1 to 5.2.2 shall be satisfied.
5.3.4	Humidity test	1) Temperature : $60\pm 2\text{ }^{\circ}\text{C}$ 2) Relative humidity : 90~95 % 3) Duration of test : 500 h 4) Take off a drop water. 5) Standard conditions after test : 1 h	Contact resistance 1000 m $\Omega$ max. No. 5.1.2 to 5.1.4 and No. 5.2.1 to 5.2.2 shall be satisfied.
5.3.5	Endurance (Switching action)	1) DC 15 V 20 mA Resistance load 2) Operation speed : 2~3 times/s 3) Push force : Maximum value of operation force 4) Operation number : 100,000 times	Contact resistance 20 $\Omega$ max. Bouncing : 10 ms max. Variation rate of operation force shall be within $\pm 30\%$ to the value before testing No. 5.1.2 and 5.2.2 shall be satisfied.
5.3.6	Withstand H <sub>2</sub> S	1) Density : $3\pm 1\text{ ppm}$ 2) Temperature : $40\pm 2\text{ }^{\circ}\text{C}$ 3) Relative humidity : 80~85 % 4) Duration of test : 24 h 5) Standard conditions after test : 1 h	Contact resistance 1000 m $\Omega$ max. No. 5.1.2 to 5.1.4 and No. 5.2.1 to 5.2.2 shall be satisfied.

Classification	SPECIFICATION	Issue No. 20100111
Part Name LIGHT TOUCH SWITCH	Part No. EVPAFGB65	6/13

## 6. Prohibitions and precaution for handling

### 6.1 Reflow soldering condition

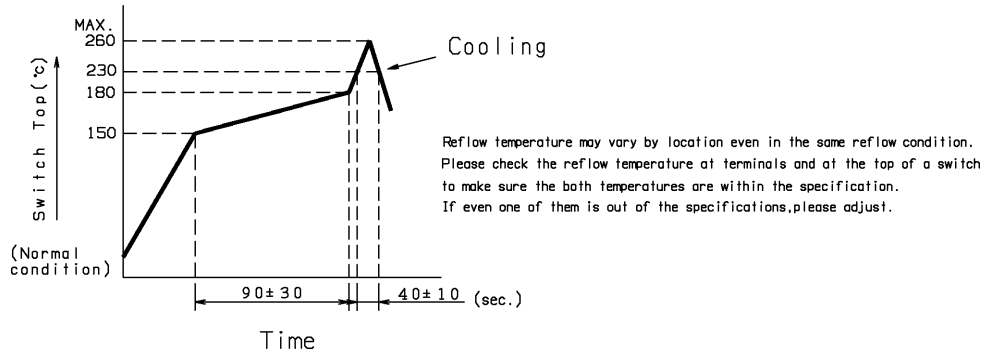

- 1) Two times max. with directing the switch mounting side of P.W.B up.
- 2) Re-soldering by soldering iron shall be allowed under 350°C max. 3 sec. max. 1 time only and the tip of iron must not touch to terminals. Soldering iron for re-soldering have to be 60W max.

### 6.2 Design instructions

- 1) Please refer to the land pattern plan Panasonic recommends on the 2nd page.
- 2) Design key top as fig-1.  
(Recommended operation condition)
- 3) Please design your knob not to hit the switch film or case even when the switch is fully pushed.
- 4) Please pay attention not to add side force (static or impact) to the push plate of the switch, especially when the switch is being built into the products. (fig-2)

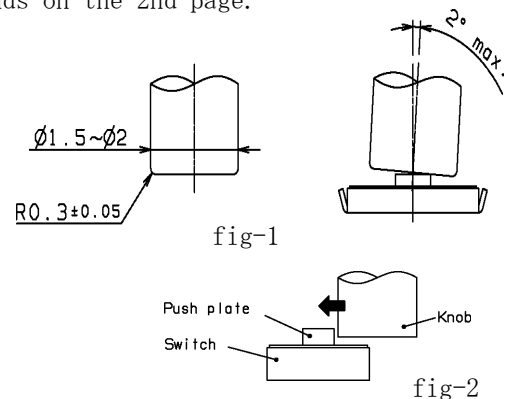

### 6.3 Notes

- 1) Please be cautions not to give excessive static load or shock to switches.
- 2) Please be careful not to pile up P.W.B. after switches were soldered.
- 3) Preservation under high temperature and high humidity or corrosive gas should be avoided especially. When you need to preserve for a long period, do not open the carton.
- 4) Avoid pressing the film portion of the product with sharp-edged object.
- 5) Cleaning
  - If flux or solder is scattered on the surface of P.W.B when soldering, characteristics of this product may be damaged.
  - Cleaning after soldering is not allowed. When cleaning is required this switch should be soldered after the cleaning.
- 6) Avoid the use of the switch under pushed ON condition is continued for a long time.
- 7) There is a possibility the flux from solder paste infiltrates into the body if plenty of solder paste was applied by switch on the P.W.B.  
So we recommend to use our proposed land design in order to prevent above problem.  
Also please avoid putting additional land by the switch on the P.W.B.

Classification

SPECIFICATION

Issue No.

20100111

Part Name LIGHT TOUCH SWITCH

Part No.

EVPAFGB65

7/13

7. Packing specification

Carrier tape

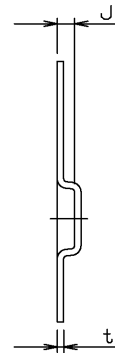
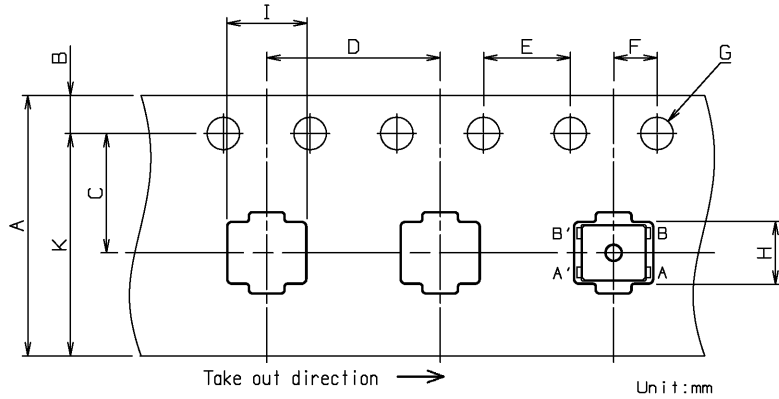

Product orientation direction

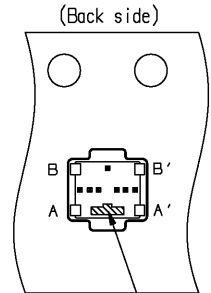

Terminal expose area

A	B	C	D	E	F	G	H	I	J	K	t
±0.3	±0.1	±0.1	±0.1	±0.1	±0.1	±0.3	±0.2	±0.2	±0.2	(10.25)	±0.1
12	1.75	5.5	8	4	2	1.5	2.95	3.75	0.8		

Taping condition : Lack of products in the middle of taping should be one MAX, but total quantity specified in the specifications should be secured.

Peeling off strength of top tape : It should be within 0.2N to 1.0N at 165 degree in peeling off angle.

Joint of carrier tape : One joint per one reel may exist.

Reel (8000pcs./reel)

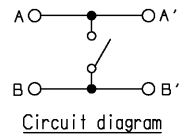

Circuit diagram

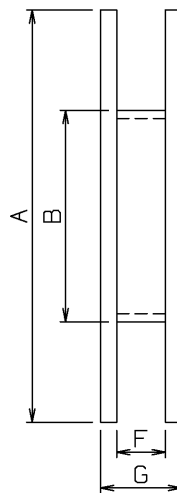
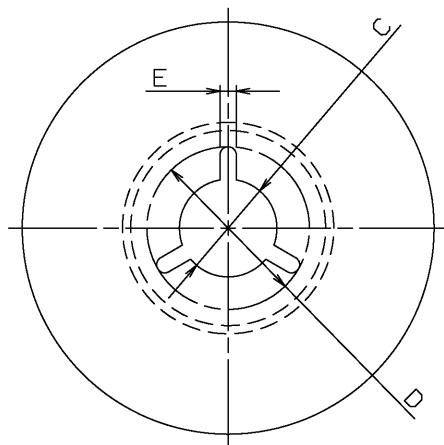

A	B	C	D	E	F	G
±2	±1	±0.5	±1	±0.5	±1	±1
∅380	∅80	∅13	∅21	2	13.5	17.5



Classification	SPECIFICATION	Issue No. 20100111
Part Name LIGHT TOUCH SWITCH	Part No. EVPAFGB65	8/13

<Prohibitions and precaution for handling>

**【Prohibited items on fire and smoking】**

- Absolutely avoid use of a product beyond its rated range because doing so may cause a fire.  
If misuse or abnormal use may result under conditions in which the product is used out of its rated range, take proper measures such as current interruption using a protective circuit.
- The grade of nonflammability for resin used in product is "94HB," which is based on UL94 Standards (flammability test for plastic materials). Prohibit use in a location where a spreading fire may be generated or prepare against a spreading fire.

**【For use in equipment for which safety is requested】**

- Although care is taken to ensure product quality, inferior characteristics, short circuits, and open circuits are some problems that might be generated, To design an equipment which places maximum emphasis on safety, review the effect of any single fault of a product in advance and perform virtually fail-safe design to ensure maximum safety by:
  - Preparing a protective circuit or a protective device to improve system safety, and equipment.
  - Preparing a redundant circuit to improve system safety so that the single fault of a product does not cause a dangerous situation.

**【Attentions required for storage condition】**

- When this product is to be stored in the following circumstances and conditions, it may affect on the performance deteriorations and solderability etc., avoid storing in the following conditions.
  - (1) A place where the temperature is -10°C max., +40°C min. and the humidity is 85% min.
  - (2) In the corrosive gas atmosphere.
  - (3) Long-term storage for 6 months min.
  - (4) A place where the product is exposed to direct sunlight.
- Store in packed condition so that the load stress is not applied.
- Please use this product as soon as possible, our recommendation is within 3 months and the limitation is 6 months.
- If any remainder left after packing is opened, store it with proper moistureproofing and gasproofing, etc.,

# Panasonic

**Handling Manual for ;**  
**3.0 mm X 2.6 mm Light Touch Switch**

Version 1.0  
Issued: Oct.9.2007

# Panasonic

## Content :

1. Instruction for set design.....	3
2. Instruction for P.W.B pattern design.....	3
3. Instruction for handling of the switch at production line	
Case 1. Handling at reflow soldering process.....	3
Case 1-1. After reflow soldering.....	3
Case 1-2. After reflow soldering.....	4
Case 2. Handling at punching process.....	4
Case 3. Handling at inspection process.....	4
Case 4. Handling of the switch (Re-work process and others) .....	4
Case 5. Others.....	5
4. About washing.....	5

# Panasonic

## 1. Instruction for set design

Please design your knob, housing and other items not to hit the push plate from side or diagonally to avoid switch failures such as push plate breaking, push plate peeling off and cover film peeling off at assembly line or in the market(while using the set).

Example:

- The push plate can not avoid hitting with the knob when the switch is installed into the housing (refer to fig-1)
- Some free-play exists between the switch and knob, then the push plate has chances to be hit by the knob.

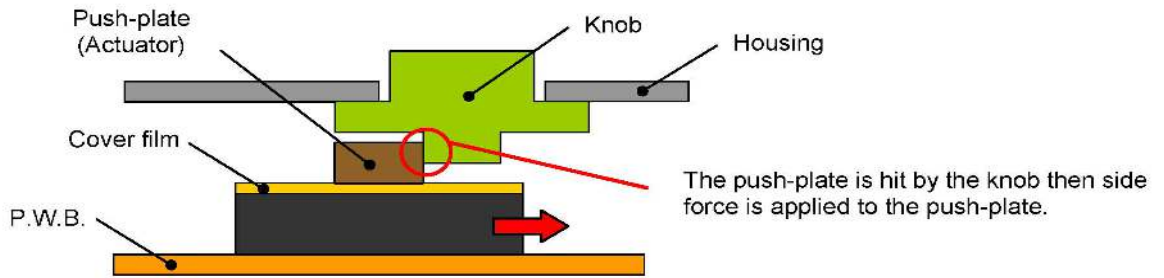

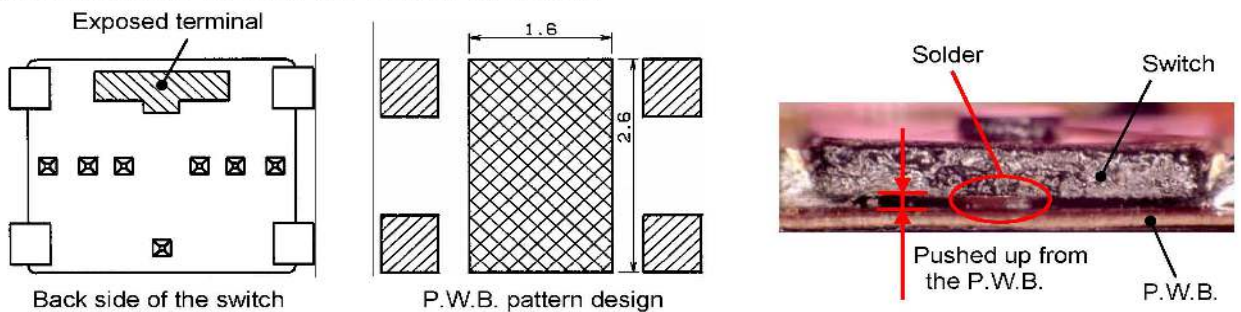

Fig1. Set design

## 2. Instruction for P.W.B pattern design

Terminal is exposed at the  part on back side of the switch. Please do not solder the exposed terminal (  part). The switch is pushed up from the P.W.B. by solder.



Any land pattern or vias shall not be provided at  area.

Fig2. P.W.B pattern design

## 3. Instruction for handling of the switch at production line

Please design your assembly process not to give side or diagonal force to the push-plate. **Please avoid handlings like examples below.**

### Case1: Handling at reflow soldering process

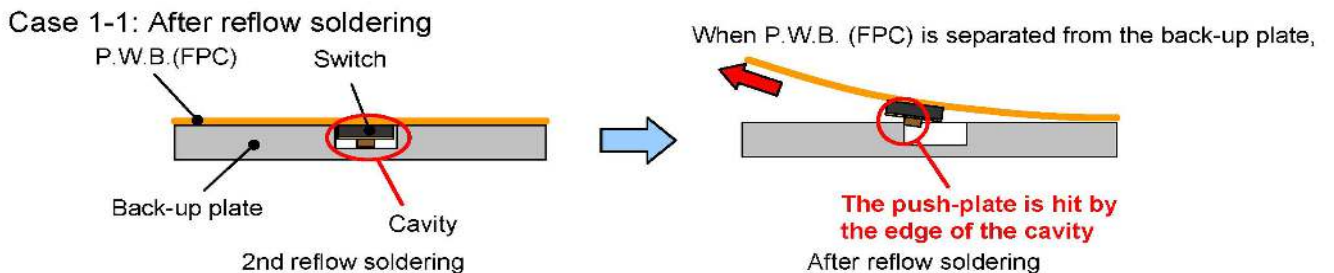

Fig3. Case 1-1

# Panasonic

## Case 1-2: After reflow soldering

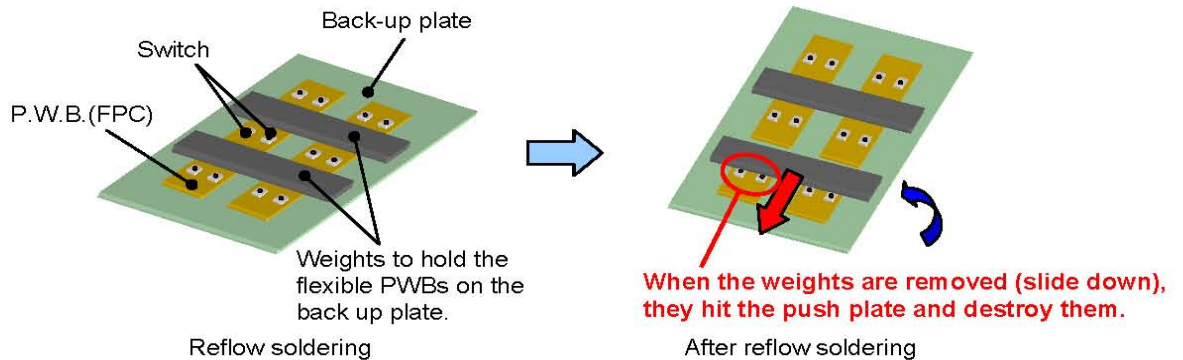

Fig4. Case 1-2

### \*Important:

- If you need to work on the switch after reflow soldering, please touch the switch after cooling them to room temperature.
- Basically upside down reflow is not recommended. If you need the 2nd reflow for the switch with upside down, please check if any issues occur with your conditions.

## Case2: Handling at punching process

The push-plate is hit by the punching die, or jigs.

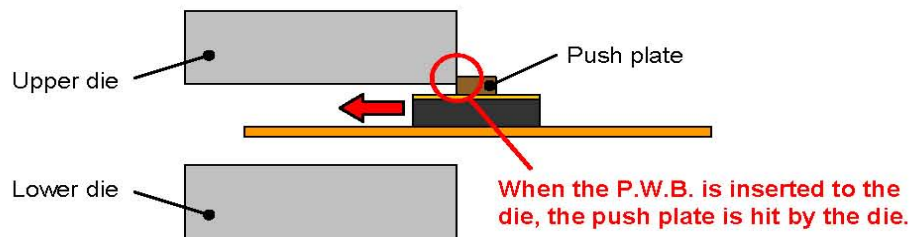

Fig5. Case2

## Case3: Handling at inspection process

The push-plate is hit by the inspection jig.

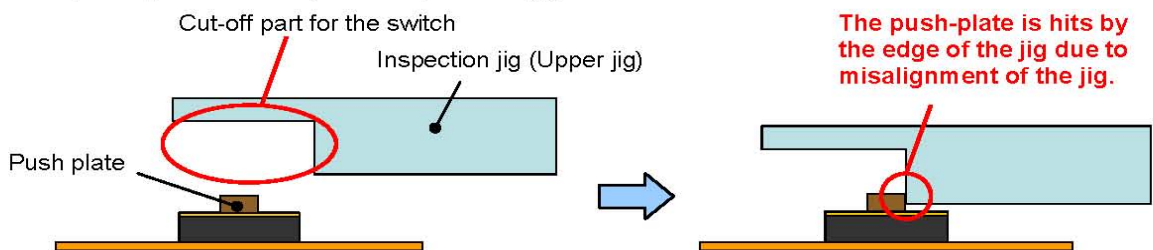

Fig6. Case3

## Case4: Handling of the switch (Re-work process and others.)

Picking up the switch by holding the push plate with tweezers.

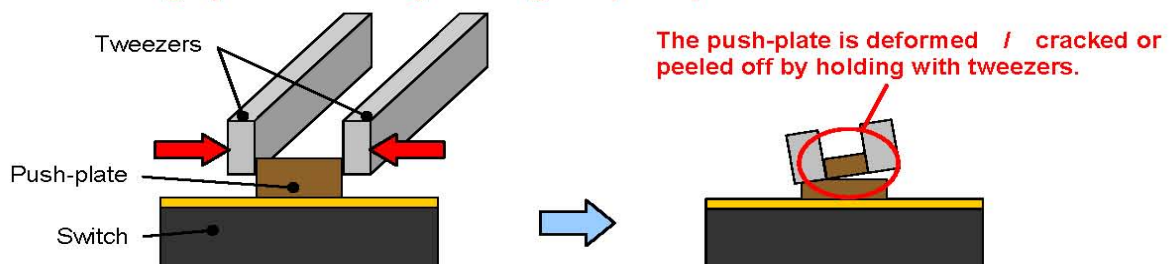

Fig7. Case4

# Panasonic

## Case5: Others

Push plate rubs against the work-top, the jig and others.

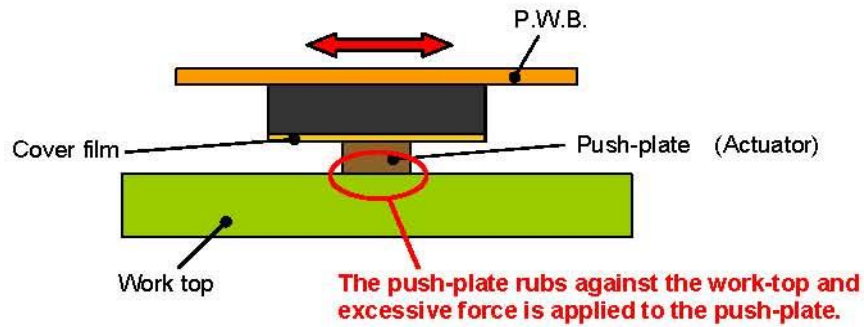

Fig8. Case5

## 4. About washing

This switch is not washable.

Please do not use alcohol for cleaning around the switch.

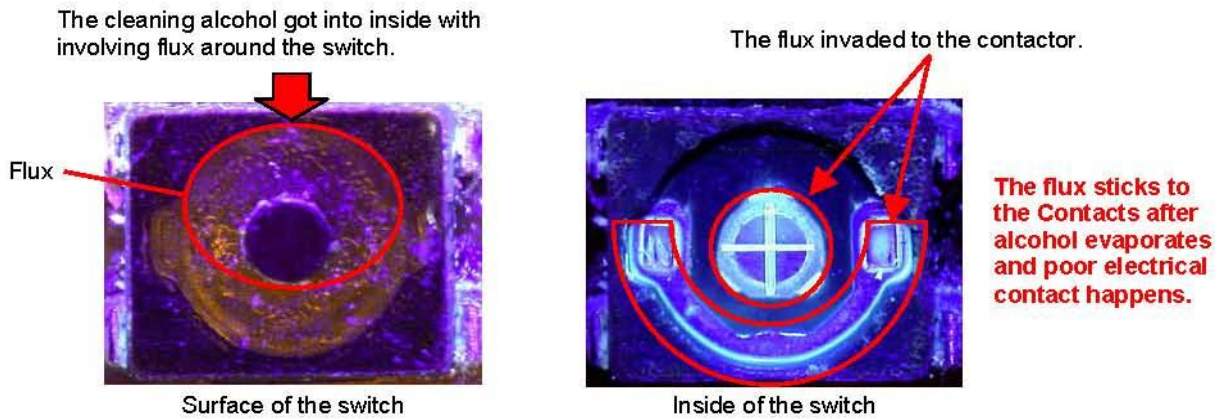

Fig9.