



## Part Number: DHI8012

### Electrical Specifications

Frequency Range (GHz):	8.0 - 12.4
Isolation (dB):	20 MIN
Insertion Loss (dB):	0.5 MAX
VSWR:	1.25:1 MIN
Forward Power (W):	25 AVG 500 PK
Reflective Power (W):	2 AVG

### Mechanical/Environmental Specifications

Connector Type:	SMA
Connector Body:	Passivated stainless steel
Connector Pin:	Gold plated copper
Load Body:	Brass
Magnetic Shunt:	Nickel plated CRS
External Coating:	Epoxy
Operational Temp:	-20°C to +85°C
Weight (oz):	0.5 MAX
Humidity:	> 95% RH
Vibration:	20grms
Shock:	20g pk
Altitude:	> 50kft
Screening Test:	Non-Operational Thermal Cycles
ATP:	Operational thermal cycling

Test Report Included w/CofC. To customize test procedures or specifications to your requirements, please contact DiTom.

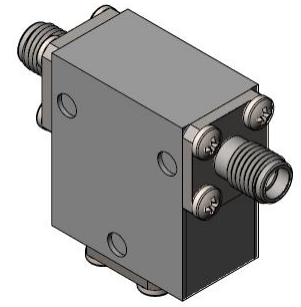

### DHI8012 Dimensions

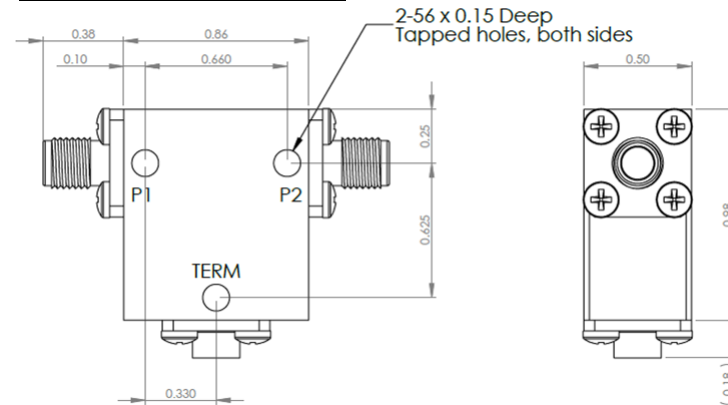

### DHI8012-3 Dimensions

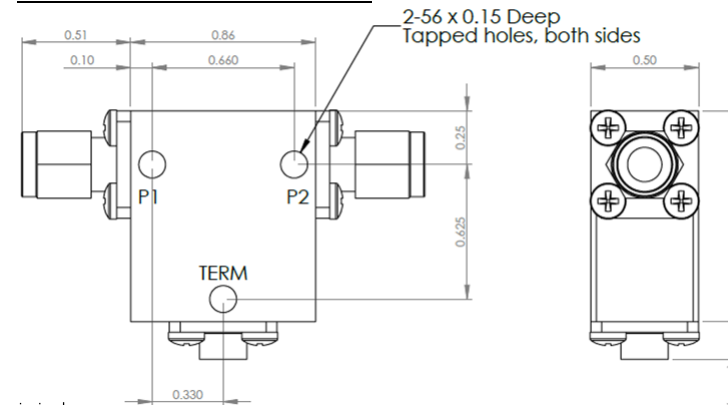

Dimensions are in inches  
Tolerance

XX	±0.03
XXX	±0.010

Type of Device	PN Suffix	Connector Configuration Input / Output	PN Example
Single and Dual Junction Isolator, 2-Port Device	N/A	Female / Female	DHI8012
	-1	Male / Female	DHI8012-1
	-2	Female / Male	DHI8012-2
	-3	Male / Male	DHI8012-3



# MEASURED DATA

Part Number: DHI8012, +25°C

