

NOTES:

1. MATERIALS OF FINISHES:  
 FERRULE - COPPER, GOLD PLATING  
 COVER - BRASS, GOLD PLATING  
 BODY - BRASS, GOLD PLATING  
 CONTACT PIN - BRASS, GOLD PLATING  
 RETAINER RING - SUS 304, NATURAL  
 GASKET - SILICONE RUBBER, RED  
 INSULATOR - PTFE, NATURAL

2. ELECTRICAL:  
 A. IMPEDANCE: 50 OHM  
 B. FREQUENCY RANGE: 0-3 GHZ  
 C. D.W.V: 500 VRMS, MIN.

3. MECHANICAL:  
 A. DURABILITY: 500 CYCLES MIN.  
 B. TEMPERATURE RANGE: -65°C TO +165°C

4. CRIMPED FERRULE HEX CRIMP SIZE .128"

5. SOLDER CABLE CENTER CONDUCTOR TO CONNECTOR CENTER CONTACT

6. CONNECTOR MEETS CORROSION REQUIREMENTS PER MIL-STD-202, METHOD 101, TEST CONDITION B

THIRD ANGLE PROJ.

REVISIONS

REV	DESCRIPTION	DATE	ECO	APPR
NC	INITIAL RELEASE	20-Apr-00	-----	GRS
A	UPDATED DRAWING FORMAT	01-May-04	-----	MZ
B	CHANGE THE BARREL O.D. TO 2.3MM, REPLACE FERRULE WITH LONGER VERSION, UPDATE DRAWING FORMAT	06-Jun-14	2706	MZ
C	ADDED NOTE 6	19-Nov-14	2830	MZ

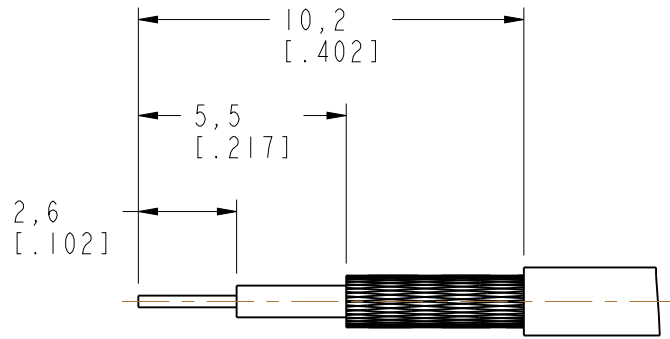

RECOMMENDED CABLE STRIPPING DIM'S

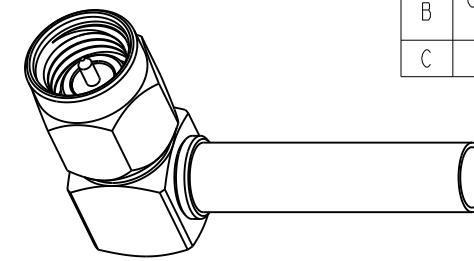

SCALE 2.000

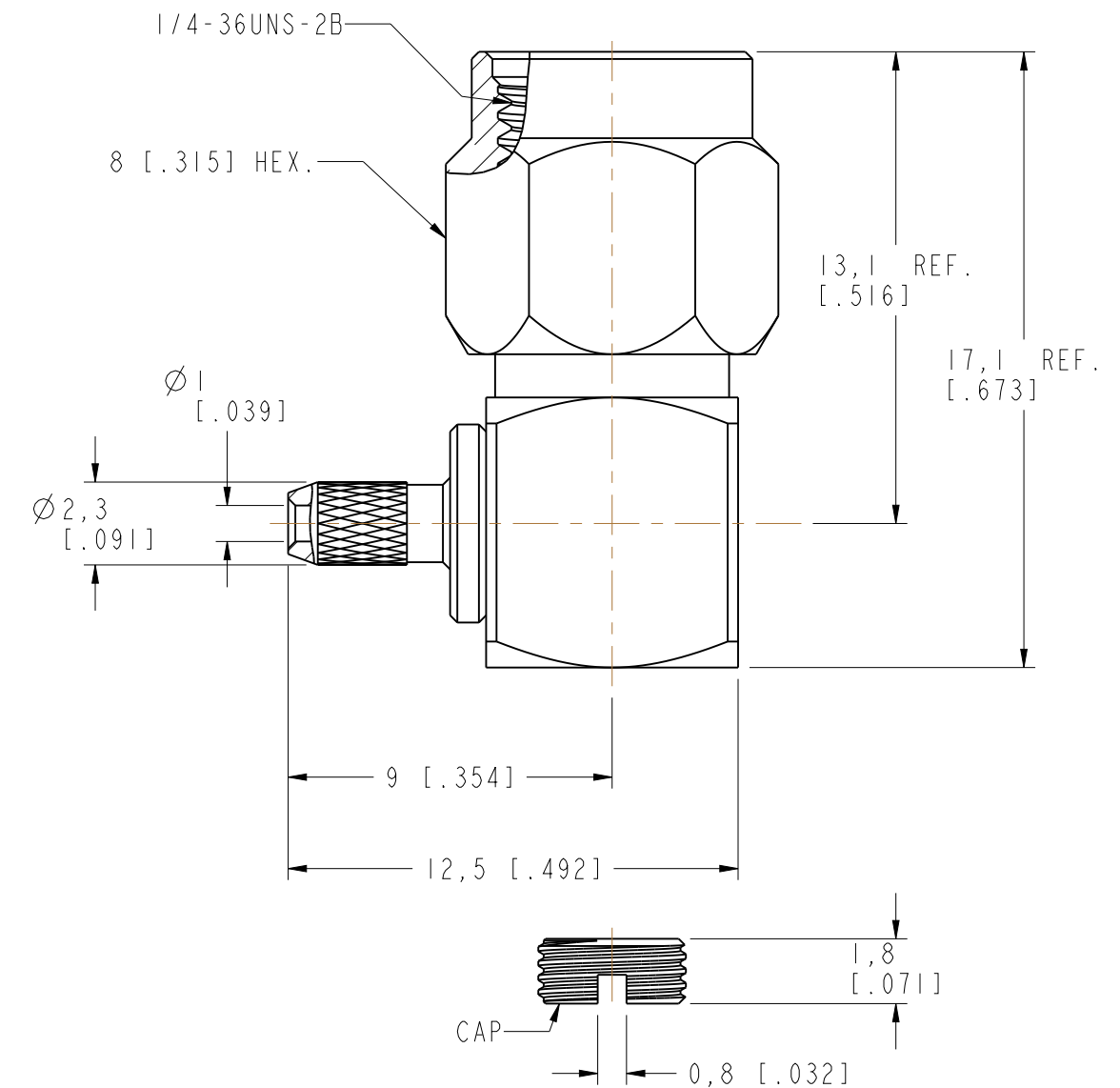
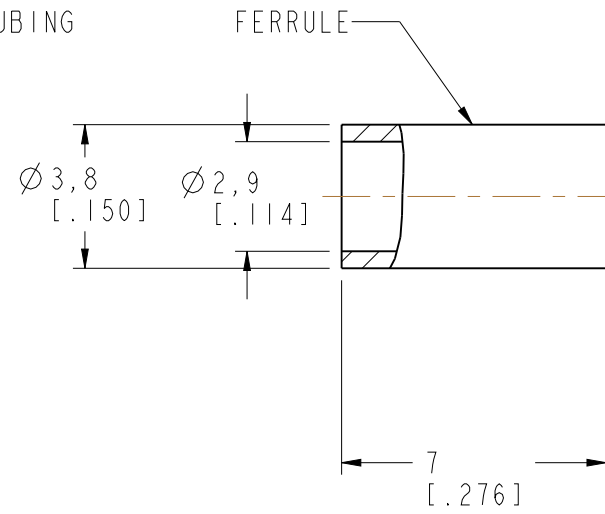
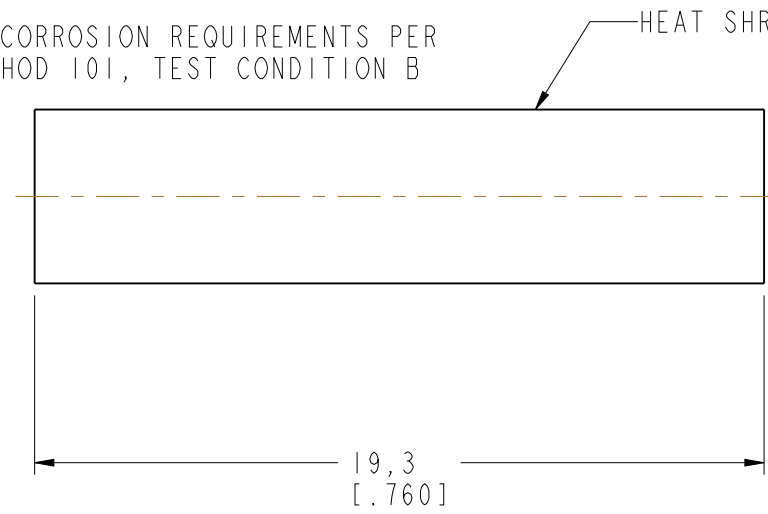

**CUSTOMER OUTLINE DRAWING**

ALL OTHER SHEETS ARE FOR INTERNAL USE ONLY

<p>UNLESS OTHERWISE SPECIFIED, DIMENSIONS ARE IN METRIC AND TOLERANCES ARE:                  &lt;0.5mm ±0.05mm    0.5 - 6mm ±0.1mm    6 - 30mm ±0.2mm    30 - 120mm ±0.3mm    ANGLES ±1°</p> <p>NOTICE - These drawings, specifications, or other data (1) are, and remain the property of Amphenol corp. (2) must be returned upon request; and (3) are confidential and not to be disclosed to any person other than those to whom they are given by Amphenol Corp. the furnishing of these drawings, specifications, or other data by Amphenol Corp., or to any other person to anyone for any purpose is not to be regarded by implication or otherwise in any manner licensing, granting rights to permitting such holder or any other person to manufacture, use or sell any product, process or design, patented or otherwise, that may in any way be related to or disclosed by said drawings, specifications, or other data.</p>	<p>MATERIAL</p>	<p>DRAWN M.ZHANG</p>	<p>DATE 19-Nov-14</p>	<p>TITLE SMA R/A CRIMP PLUG (FOR RG-178B/U, 196A/U CABLE)</p>	<p>Amphenol Connex</p>	
	<p>REFERENCE EAR# 6529 SMA112A3-015-3GT5GP-50 CONFIGURATION LEVEL: In Work</p>	<p>ENGINEER S.DUAN</p>	<p>DATE 19-Nov-14</p>			<p>DRAWING NO.</p>
<p>FINISH</p>	<p>APPROVED S.HSIEH</p>	<p>DATE 19-Nov-14</p>	<p>CAD FILE</p>	<p>SCALE: 5.0:1.0   SHEET 3 OF 3</p>	<p>ITEM NO.</p>	
				<p>DWG SIZE B</p>	<p>REV C</p>	<p>PART NO. 132173</p>