

- 1 HOUSING MATERIAL: GLASS-FILLED POLYESTER. COLOR: GRAY.
- 2 CONTACT MATERIAL: PHOSPHOR BRONZE.
- 3 CONTACT FINISH: 0.00076[.000030] GOLD IN CONTACT AREA. 0.00127[.000050] NICKEL UNDERPLATE ALL OVER. TIN-LEAD ON POSTS.
- 4 PART NUMBER, DATE CODE IDENTIFICATION, CSA LOGO IN THIS APPROXIMATE AREA ON REVERSE SIDE.
- 5 POINT OF MEASUREMENT FOR GOLD.
- 6 RECOMMENDED HOLE SIZE FOR MANUAL APPLICATION OF CONNECTOR ONTO PC BOARD.
- 7 CONTACT FINISH: DIN 41612 CLASS 3 IN CONTACT AREA. TIN-LEAD ON POSTS.
- 8 CONTACT FINISH: DIN 41612 CLASS 2 IN CONTACT AREA. TIN-LEAD ON POSTS.

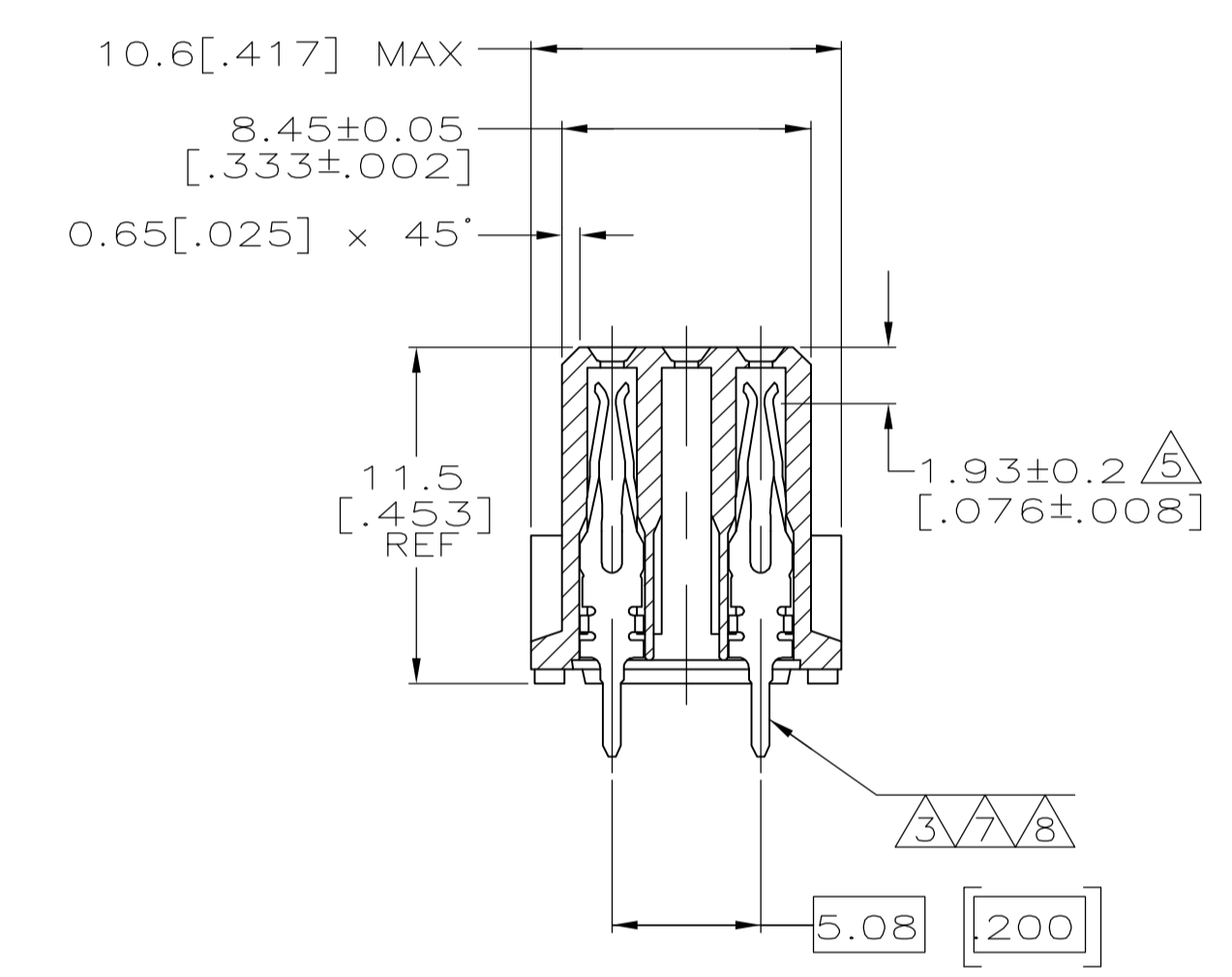

OBSELETE	1 THRU 32	X	-	X	64	650458-9
	1 THRU 32	X	-	X	64	650458-5
SUPERSEDED BY 650458-5	1 THRU 32	X	-	X	64	650458-4
NOTE	POSITIONS LOADED	C	B	A	NO. OF LOADED POSITION	ASSY PART NUMBER

THIS DRAWING IS A CONTROLLED DOCUMENT.		DIN L BRINER 3/15/90	Tyco Electronics Corporation Harrisburg, PA 17105-3608	
DIMENSIONS: mm [INCHES]		CHK N. DRASHER 3/22/90	EUROCARD, RECEPTACLE ASSEMBLY, TYPE C	
TOLERANCES UNLESS OTHERWISE SPECIFIED:		APVD	RESTRICTED TO	
0 PLC	± -	PRODUCT SPEC	-	
1 PLC	± -	APPLICATION SPEC	-	
2 PLC	± -	SIZE	A1	00779
3 PLC	± 0.13 [.005]	WEIGHT	650458	
4 PLC	± -	CUSTOMER DRAWING	SCALE 4:1 SHEET 1 OF 1 REV G	
ANGLES	± -			