

THIS DRAWING IS UNPUBLISHED. RELEASED FOR PUBLICATION  
 © COPYRIGHT copyright.d8Te- ALL RIGHTS RESERVED.

REVISIONS					
P	LTR	DESCRIPTION	DATE	DWN	APVD
A		INITIAL RELEASE	01JUN2019	JZ	CW
A1		ECR-19-019346	12DEC2019	BP	CW
B		ECR-20-013880	16NOV2021	BP	CW

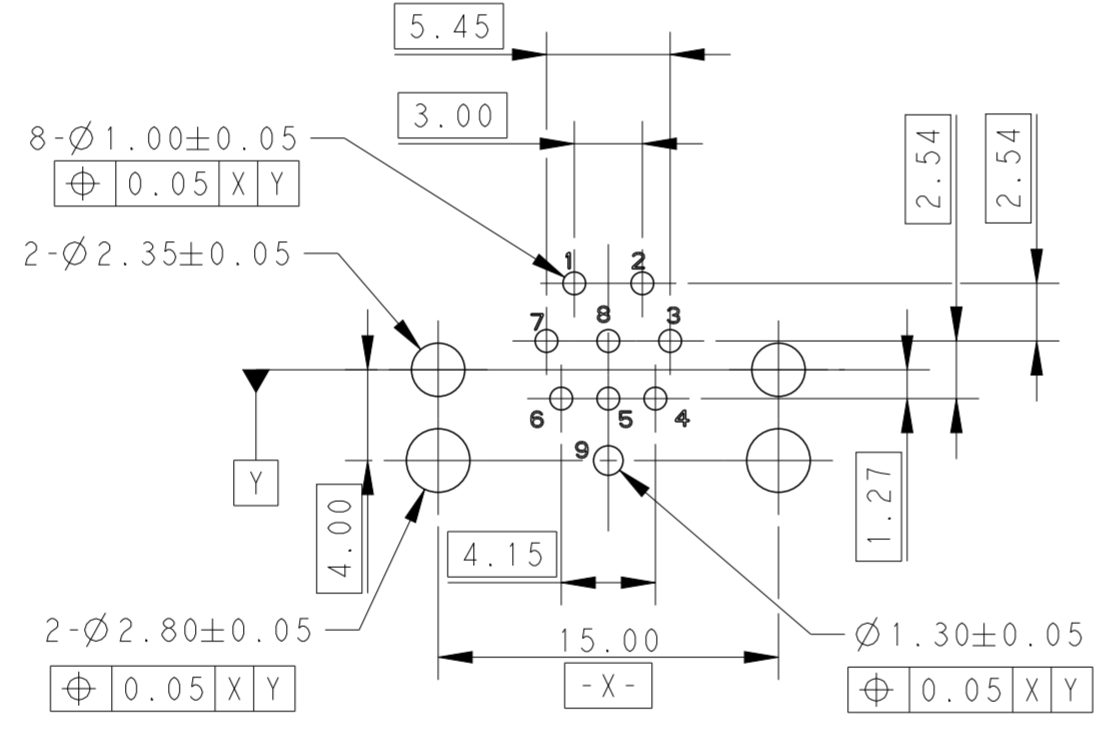

RECOMMENDED PCB LAYOUT FOR T4145035081-002(TOP VIEW)  
 PCB THICKNESS: 1.6mm

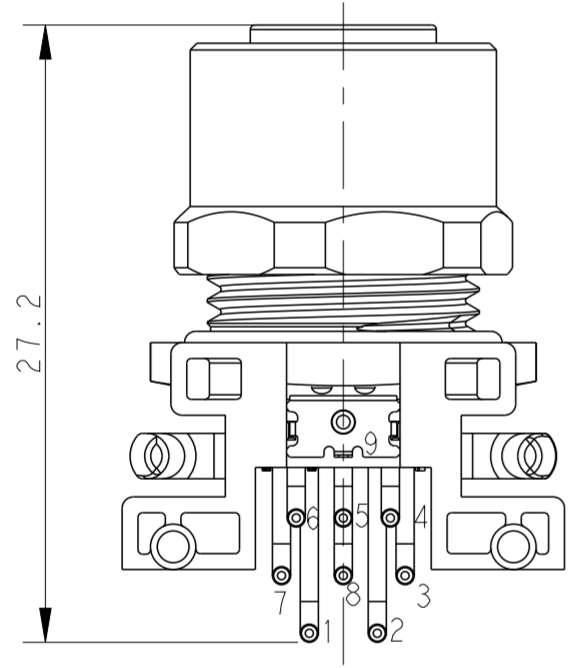
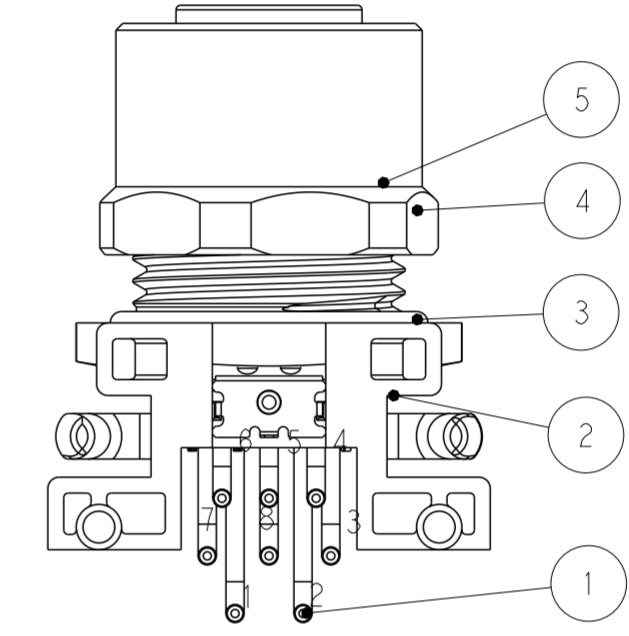
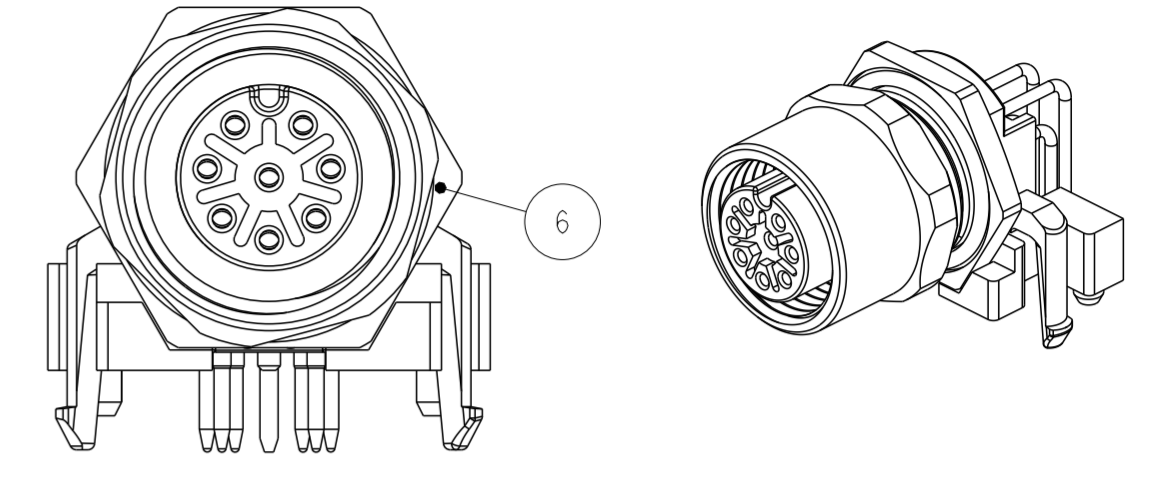
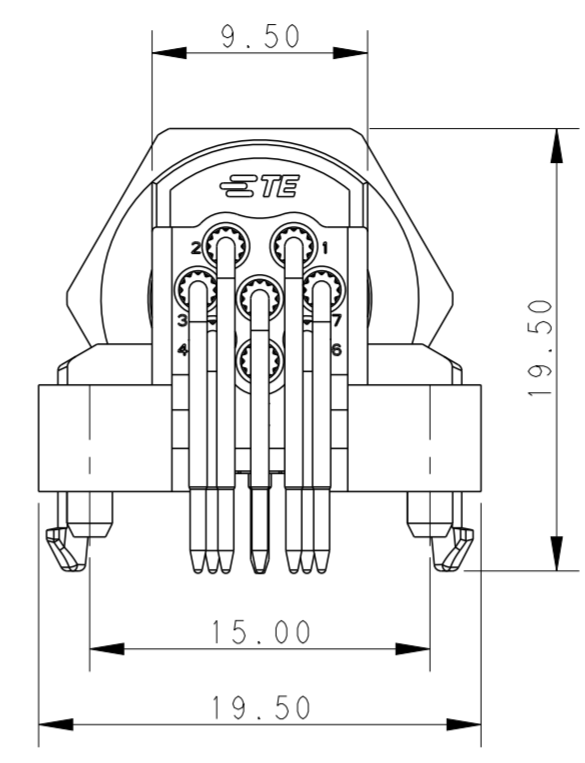
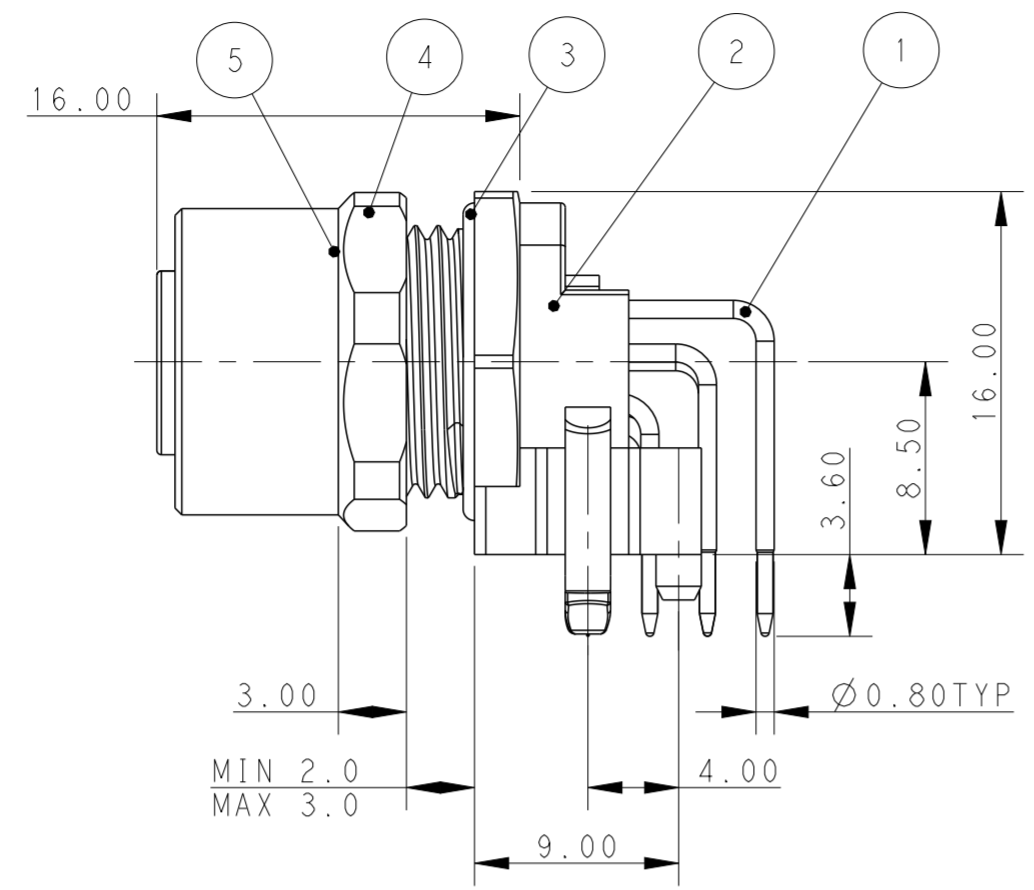
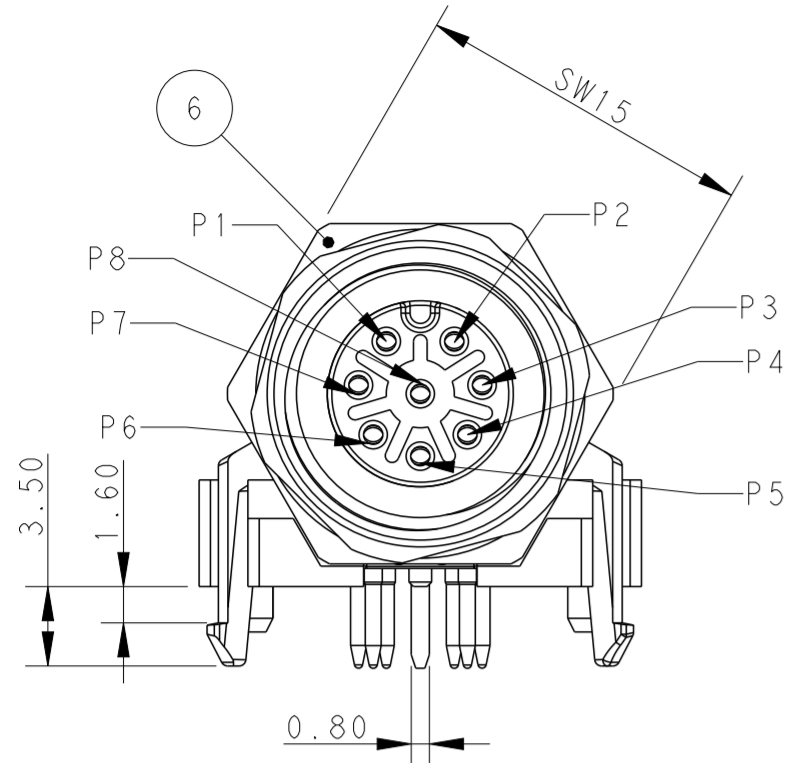
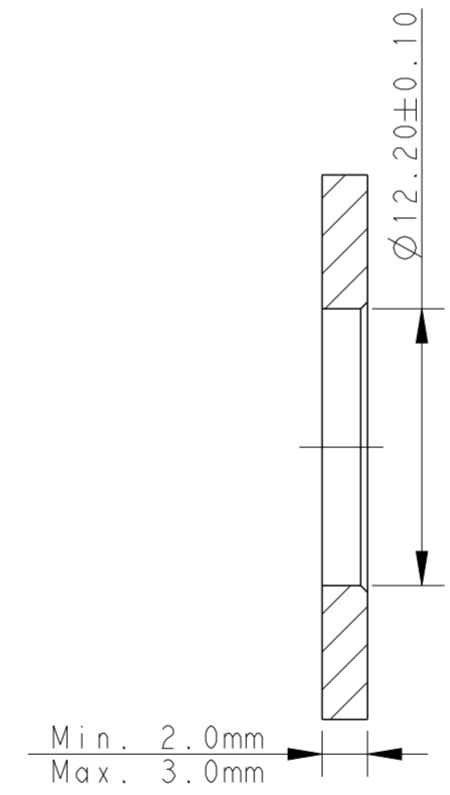

RECOMMENDED PANEL SIZE

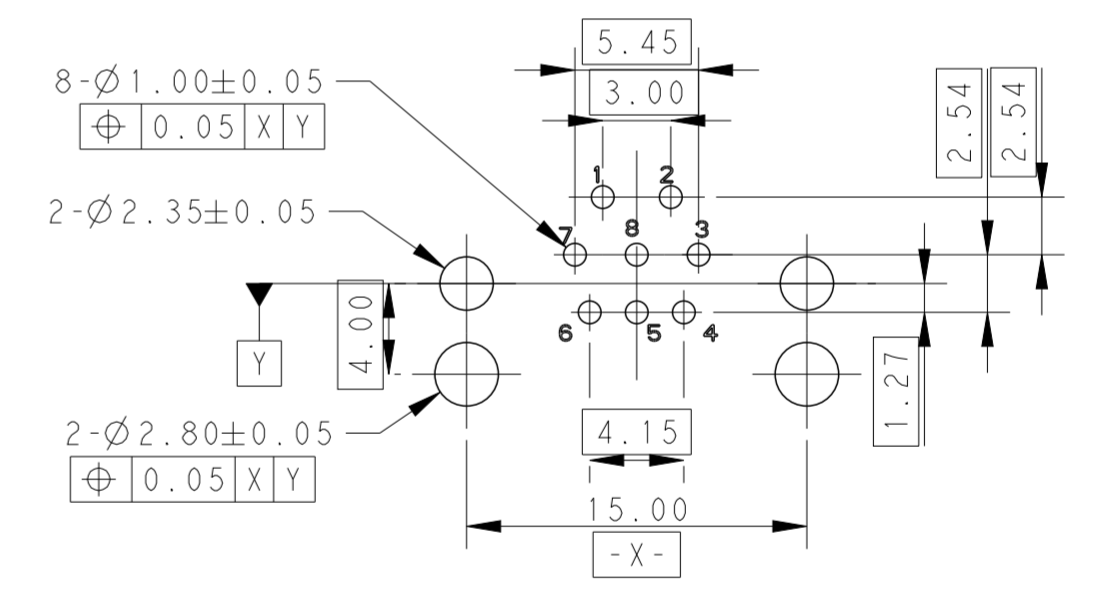

RECOMMENDED PCB LAYOUT FOR T4145015081-002(TOP VIEW)  
 PCB THICKNESS: 1.6mm

TABLE 1

PART NUMBER	T4145015081-002	T4145035081-002
PIN ARRANGEMENT	A-CODE	A-CODE
POS	8	8
SHIELD TYPE	UNSHIELDED	SHIELDED
RATED VOLTAGE	30V	30V
TATED IMPULSE VOLTAGE	800V	800V
RATED CURRENT	2A	2A
POLLUTION DEGREE	3	3
OVERVOLTAGE CATEGORY	II	II
MATERIAL GROUP	II	II
CONTACT RESISTANCE	≤10mΩ	≤10mΩ
INSULATION RESISTANCE	>100MΩ	>100MΩ
DEGREE OF PROTECTION	IP67	IP67
OPERATION TEMPERATURE	-40~85°C	-40~85°C

NOTES:

1. TECHNICAL DATA: SEE TABLE 1
2. RECOMMEND TORQUE 1Nm
3. ALL PRODUCT MUST COMPLIANCE WITH ROHS AND REACH.

ITEM	DESCRIPTION	MATERIAL	COMMENTS
7	SHIELDING	BRASS	ONLY FOR SHIELDED TYPE
6	NUT	BRASS	-
5	O-RING	SILICONE	-
4	COUPLING NUT	BRASS	-
3	O-RING	SILICONE	-
2	HOUSING	PA	BALCK COLOR
1	CONTACT	BRONZE	GOLD FLASH

THIS DRAWING IS A CONTROLLED DOCUMENT.		DWN JEREMY ZHANG 30-Nov-21	TE Connectivity	
DIMENSIONS: mm		CHK GINO YAO 30-Nov-21		
TOLERANCES UNLESS OTHERWISE SPECIFIED:		APVD CHRIS WANG 30-Nov-21	NAME M12 RECEPTACLE CONNECTOR PCB ASSEMBLY, FEMALE ANGLED, SHIELDED AND UNSHIELDED A-CODE	
0 PLC ±		PRODUCT SPEC 108-106140	SIZE A2	
1 PLC ±0.25		APPLICATION SPEC 114-137144	CAGE CODE -	
2 PLC ±0.15		WEIGHT -	DRAWING NO. C-T41450X5081XXX	
3 PLC ±		RESTRICTED CUSTOMER	RESTRICTED TO -	
4 PLC ±			SCALE 2:1 SHEET 1 OF 1 REV B	
ANGLES ±				
FINISH -				