

OSRAM SFH 5701 A01

Datasheet

Published by **ams-OSRAM AG**

Tobelbader Strasse 30, 8141 Premstaetten, Austria

Phone +43 3136 500-0

ams-osram.com

© All rights reserved



Chip LED

SFH 5701 A01

Ambient Light Sensor

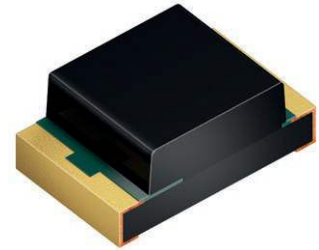

Applications

- Ambient Light Sensors
- Gesture Recognition
- Industrial Automation (Machine Controls, Light Barriers, Vision Controls)
- Remote Control, Proximity, Ambient Light Sensing
- Smart Home, Metering

Features

- Qualifications: AEC-Q102 Qualified
- ESD: 2 kV acc. to ANSI/ESDA/JEDEC JS-001 (HBM)
- Spectral sensitivity adapted to human eye sensitivity (V_λ)
- Analog output current is proportional to Ambient Light Intensity
- Integrated dark current suppression
- Built in thermal compensation
- Linear response over 6 decades of illumination range

Ordering Information

| Type | Output current ¹⁾ typ. E _v = 100 lx; (white LED); V _{DD} = 5 V ; T _A = 25 °C I _{OUT} | Ordering Code |
|--------------|---|---------------|
| SFH 5701 A01 | 135 µA | Q65112A5751 |

Maximum Ratings

| Parameter | Symbol | | Values |
|--|-----------|--------------|------------------|
| Operating temperature | T_{op} | min. max. | -40 °C 100 °C |
| Storage temperature | T_{stg} | min. max. | -40 °C 100 °C |
| Forward voltage for definition of current polarity refer to Appnote AN132 | V_F | max. | 0.56 V |
| Forward current for definition of current polarity refer to Appnote AN132 | I_F | max. | 0.5 mA |
| Supply current for definition of current polarity refer to Appnote AN132 | I_{DD} | max. | 15 mA |
| Supply voltage for definition of current polarity refer to Appnote AN132 | V_{DD} | max. | 6 V |
| ESD withstand voltage acc. to ANSI/ESDA/JEDEC JS-001 (HBM) | V_{ESD} | max. | 2 kV |
| ESD withstand voltage acc. to JEDEC JESD22-C101 (CDM) | V_{ESD} | max. | 750 V |
| ESD withstand voltage acc. to JEDEC JESD22-A115 (MM) | V_{ESD} | max. | 400 V |

Operating Conditions

| Parameter | Symbol | Values | |
|---|----------|--------|---------------------|
| Illuminance | E_V | min. | 0.01 lx |
| | | max. | 10000 lx |
| Supply current $V_{DD} = 5\text{ V}$, for the choice of R_{LOAD} refer to Appnote AN132 | I_{DD} | min. | 0.01 μA |
| | | max. | 10000 μA |
| Supply voltage for the choice of R_{LOAD} refer to Appnote AN132 | V_{DD} | min. | 1.45 V |
| | | max. | 5.5 V |

Characteristics

 $T_A = 25\text{ °C}$

| Parameter | Symbol | | Values |
|---|--------------------------|--------------|------------------------|
| Spectral sensitivity $E_v = 100\text{ lx}$; white LED; $V_{DD} = 5\text{ V}$ | S | typ. | 1000 nA/lx |
| Wavelength of maximum sensitivity | $\lambda_{S\text{ max}}$ | typ. | 600 nm |
| Spectral range of sensitivity | $\lambda_{10\%}$ | typ. | 450 ... 705 nm |
| Dimensions of active chip area | L x W | typ. | 0.33 x 0.33 mm x mm |
| Half angle | φ | typ. | 60 ° |
| Output dark current $E_v = 0\text{ lx}$; $V_{DD} = 5\text{ V}$ | I_{OUT_dark} | max. typ. | 50 nA 3.4 nA |
| Supply current $E_v = 100\text{ lx}$; white LED; $V_{DD} = 5\text{ V}$ | I_{DD} | typ. | 135 μ A |
| Rise time $R_L = 33\text{ k}\Omega$; $E_v = 100\text{ lx}$; for different testing conditions refer to the Appnote AN132 | t_r | typ. | 14000 μ s |
| Forward voltage $I_F = 0.2\text{ mA}$; $E = 0$ | V_F | typ. | 0.52 V |
| Output impedance | Z_{OUT} | typ. | 10 M Ω |
| Temperature coefficient of operating current | $TC_{I_{out}}$ | typ. | -0.07 % / K |

Relative Spectral Sensitivity ^{1), 2)}

$$S_{rel} = f(\lambda)$$

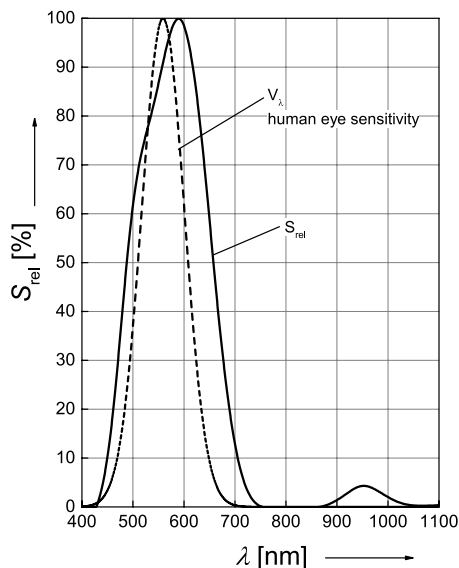

Directional Characteristics ^{1), 2)}

$$S_{rel} = f(\varphi)$$

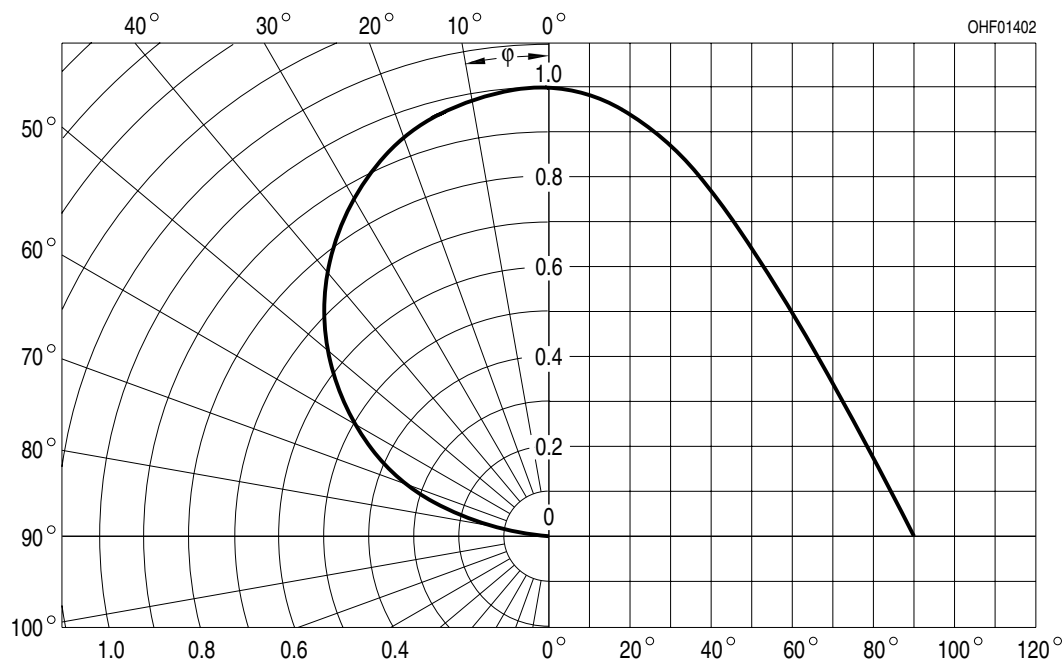

Forward current ^{1), 2)}

$$I_F = f(V_F); E = 0$$

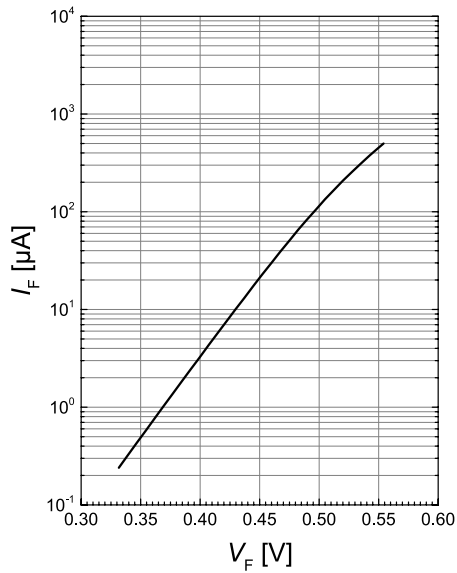

Dark Current ^{1), 2)}

$$I_{\text{OUT_dark}} = f(V_{\text{DD}}); E = 0$$

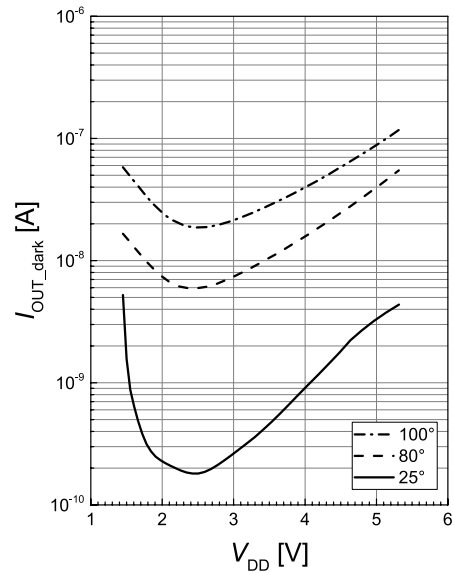

Output Current ^{1), 2)}

$$I_{\text{OUT}} = f(E_V); \text{white LED}; V_{\text{DD}} = 5 \text{ V}$$

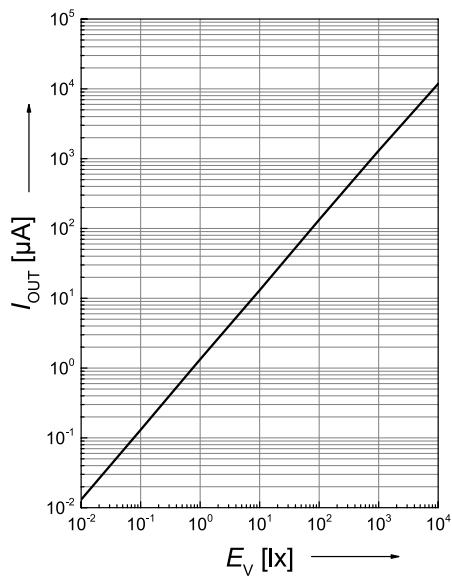

Dark Current ¹⁾

$$I_{\text{OUT_dark}} = f(T_A); V_{\text{DD}} = 5 \text{ V}; E = 0$$

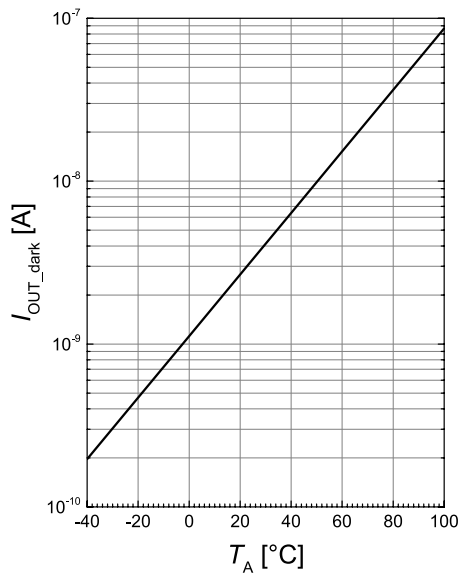

Output Current ^{1), 2)}

$$I_{\text{OUT,rel}} = f(T_A); V_{\text{DD}} = 5 \text{ V}; E_V = 100 \text{ lx}; \text{white LED}$$

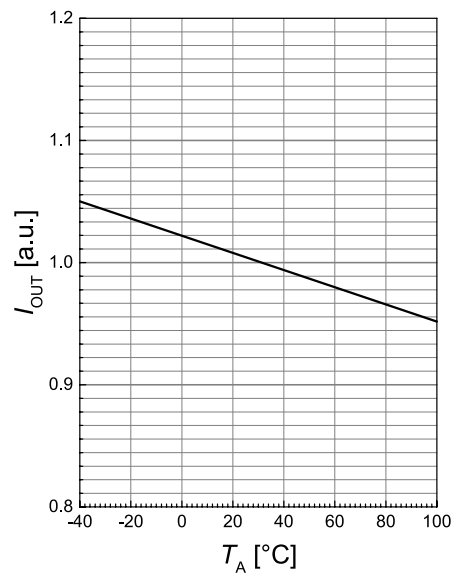

Dimensional Drawing ³⁾

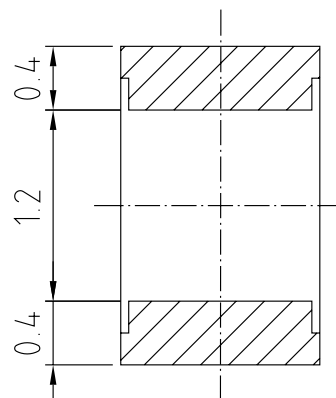
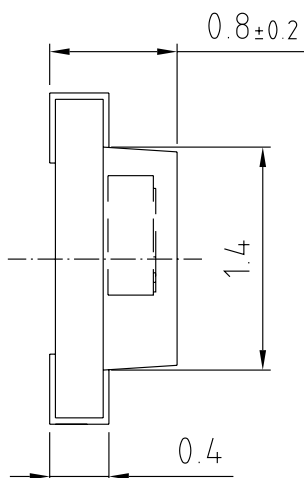
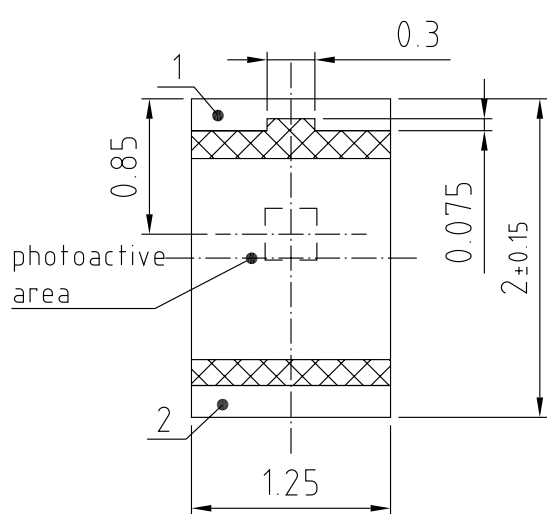

general tolerance ± 0.1
lead finish Au

C67062-A0260-A1KA-03

Further Information:

Approximate Weight: 3.8 mg

| Pin | Description |
|-----|---------------|
| 1 | anode (OUT) |
| 2 | cathode (VDD) |

Recommended Solder Pad ³⁾

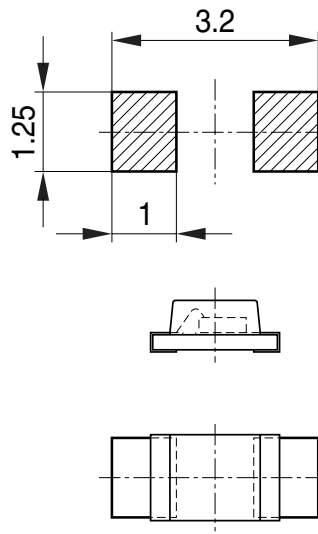

Bauteil positioniert
Component location on pad

OHFP2578

Reflow Soldering Profile

Product complies to MSL Level 3 acc. to JEDEC J-STD-020E

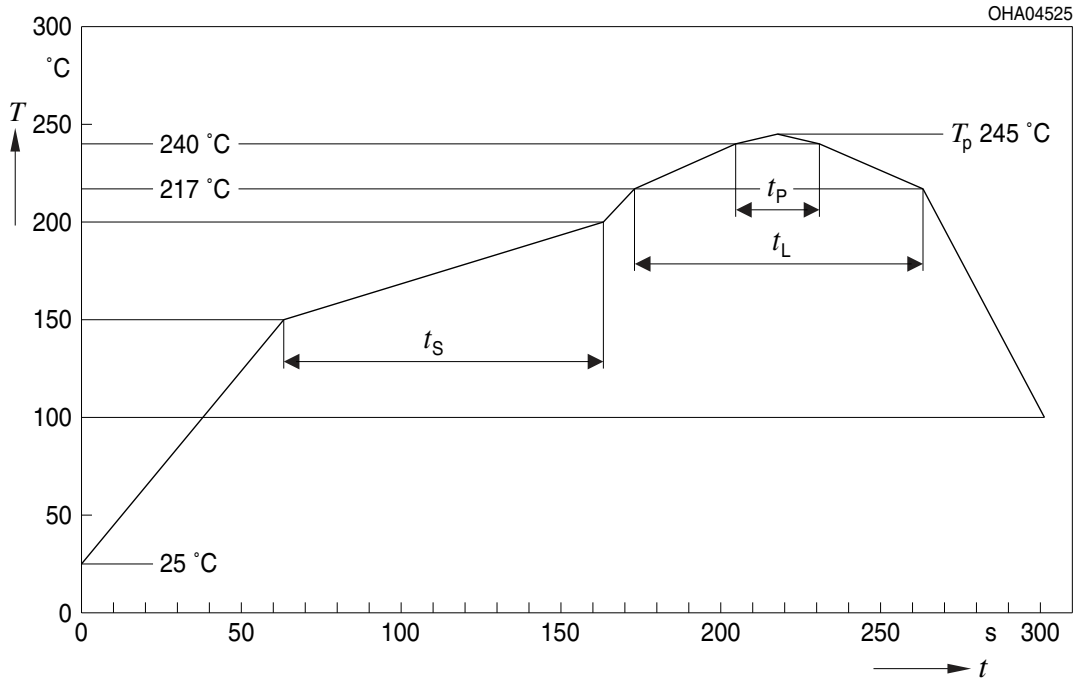

| Profile Feature | Symbol | Pb-Free (SnAgCu) Assembly | | | Unit |
|--|--------|---------------------------|----------------|---------|------|
| | | Minimum | Recommendation | Maximum | |
| Ramp-up rate to preheat ^{*)} 25 °C to 150 °C | | | 2 | 3 | K/s |
| Time t_s T_{Smin} to T_{Smax} | t_s | 60 | 100 | 120 | s |
| Ramp-up rate to peak ^{*)} T_{Smax} to T_p | | | 2 | 3 | K/s |
| Liquidus temperature | T_L | | 217 | | °C |
| Time above liquidus temperature | t_L | | 80 | 100 | s |
| Peak temperature | T_p | | 245 | 260 | °C |
| Time within 5 °C of the specified peak temperature $T_p - 5$ K | t_p | 10 | 20 | 30 | s |
| Ramp-down rate* T_p to 100 °C | | | 3 | 6 | K/s |
| Time 25 °C to T_p | | | | 480 | s |

All temperatures refer to the center of the package, measured on the top of the component
^{*)} slope calculation DT/Dt : Dt max. 5 s; fulfillment for the whole T-range

Tape and Reel ⁴⁾

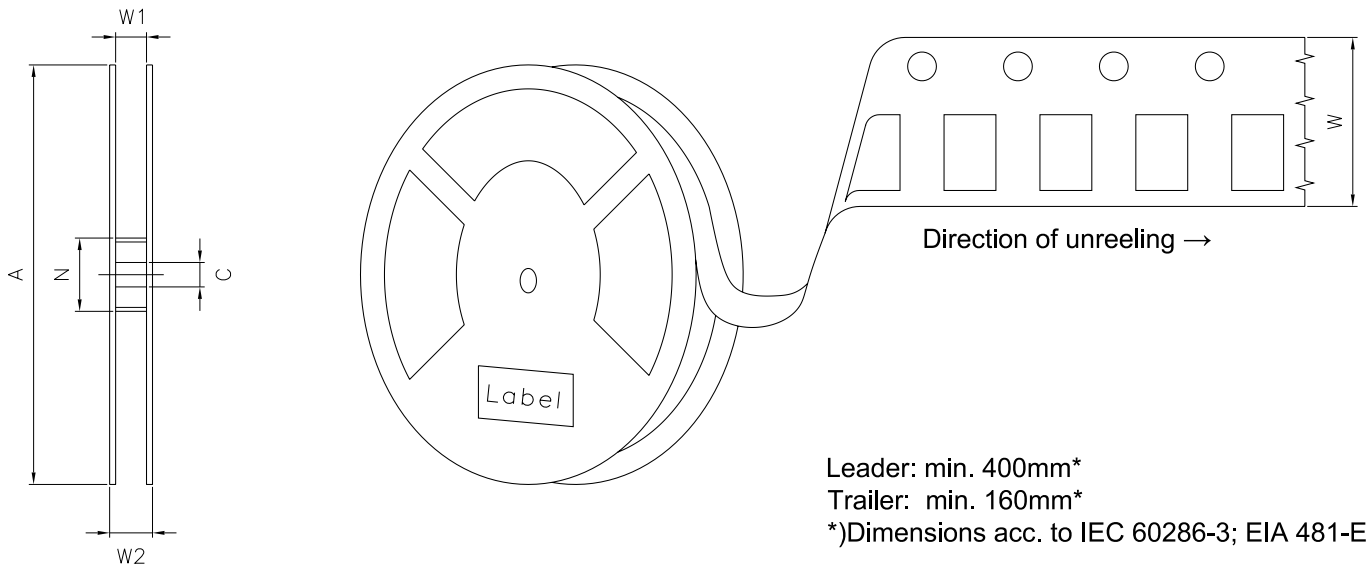

Reel Dimensions

| A | W | N_{\min} | W_1 | $W_{2\max}$ | Pieces per PU |
|--------|----------------------|------------|--------------|-------------|---------------|
| 180 mm | $8 + 0.3 / - 0.1$ mm | 60 mm | $8.4 + 2$ mm | 14.4 mm | 3000 |

Barcode-Product-Label (BPL)

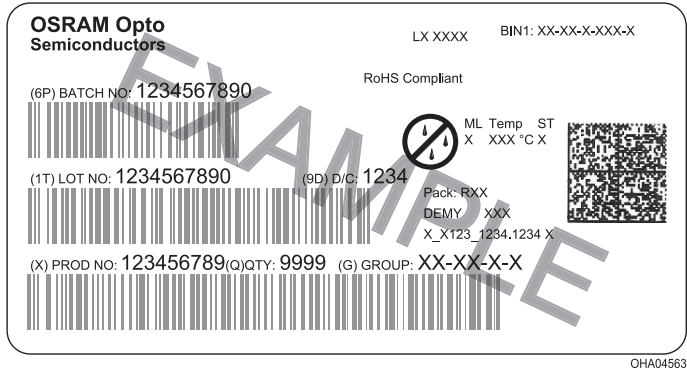

Dry Packing Process and Materials

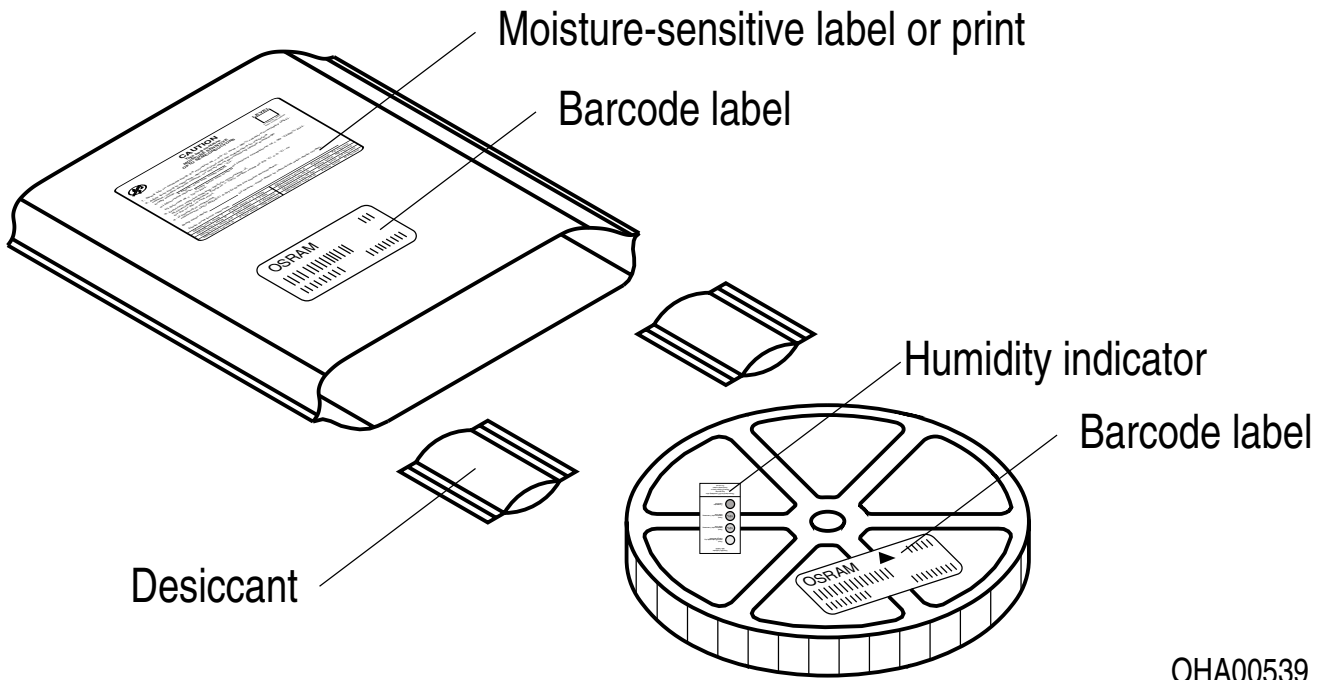

Disclaimer

Attention please!

The information describes the type of component and shall not be considered as assured characteristics. Terms of delivery and rights to change design reserved. Due to technical requirements components may contain dangerous substances.

For information on the types in question please contact our Sales Organization.

If printed or downloaded, please find the latest version on our website.

Packing

Please use the recycling operators known to you. We can also help you – get in touch with your nearest sales office. By agreement we will take packing material back, if it is sorted. You must bear the costs of transport. For packing material that is returned to us unsorted or which we are not obliged to accept, we shall have to invoice you for any costs incurred.

Product and functional safety devices/applications or medical devices/applications

Our components are not developed, constructed or tested for the application as safety relevant component or for the application in medical devices.

Our products are not qualified at module and system level for such application.

In case buyer – or customer supplied by buyer – considers using our components in product safety devices/ applications or medical devices/applications, buyer and/or customer has to inform our local sales partner immediately and we and buyer and /or customer will analyze and coordinate the customer-specific request between us and buyer and/or customer.

Glossary

- 1) **Typical Values:** Due to the special conditions of the manufacturing processes of semiconductor devices, the typical data or calculated correlations of technical parameters can only reflect statistical figures. These do not necessarily correspond to the actual parameters of each single product, which could differ from the typical data and calculated correlations or the typical characteristic line. If requested, e.g. because of technical improvements, these typ. data will be changed without any further notice.
- 2) **Testing temperature:** TA = 25°C (unless otherwise specified)
- 3) **Tolerance of Measure:** Unless otherwise noted in drawing, tolerances are specified with ± 0.1 and dimensions are specified in mm.
- 4) **Tape and Reel:** All dimensions and tolerances are specified acc. IEC 60286-3 and specified in mm.

Revision History

| Version | Date | Change |
|---------|------------|--|
| 1.0 | 2019-01-23 | Initial Version |
| 1.1 | 2019-01-28 | Features |
| 1.2 | 2020-08-13 | New Layout Taping Schematic Transportation Box Dimensions of Transportation Box |
| 1.3 | 2020-09-08 | Ordering Information |
| 1.4 | 2021-09-30 | Brand |
| 1.5 | 2022-02-23 | Features New Layout |



EU RoHS and China RoHS compliant product

此产品符合欧盟 RoHS 指令的要求；
按照中国的相关法规和标准，
不含有毒有害物质或元素。

Published by ams-OSRAM AG

Tobelbader Strasse 30, 8141 Premstaetten, Austria

Phone +43 3136 500-0

ams-osram.com

© All rights reserved

am 

OSRAM