

6

5

4

3

2

1

E

E

D

D

C

C

B

B

A

A

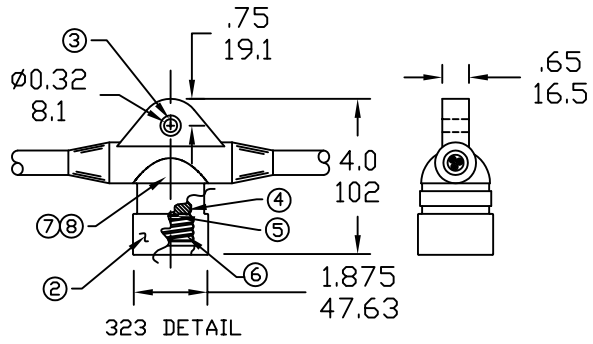
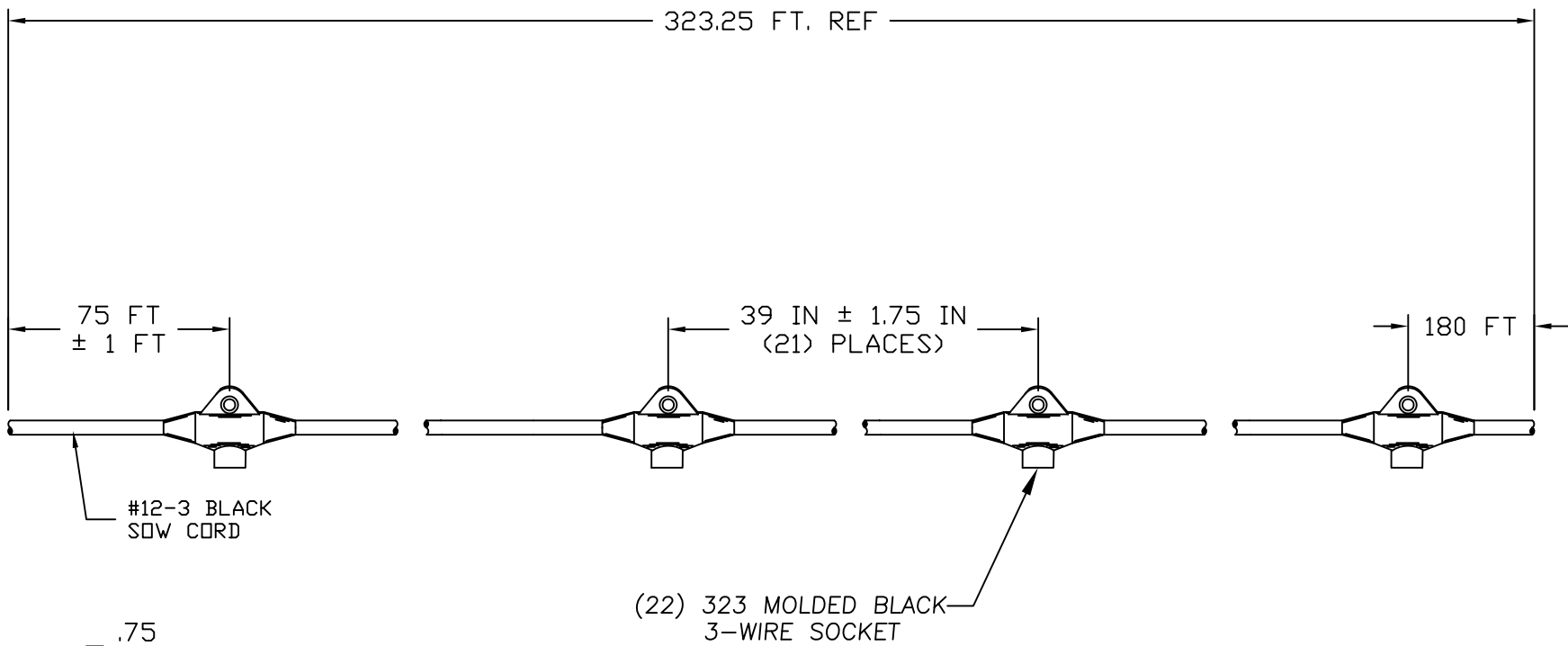

ITEM	DESCRIPTION	MATERIAL
1	#12-3 BLACK CABLE	SOOW/COPPER
2	MOLDED SOCKETS BLACK	NITRILE/PVC
3	EYELET	BRASS
4	BUTTON WHITE	PORCELAIN
5	RIVET	BRASS
6	SCREWSHELL	COOPER
7	1 CONDUCTOR WIRE BLACK	NEOPRENE
8	1 CONDUCTOR WIRE WHITE	NEOPRENE

NOTE:
THE SOCKETS SHOULD NOT HAVE GROUND RINGS; NON-METALLIC GUARDS SHOULD BE USED.

RELEASE DRAWING EC NO: WNA2011-0173 DRWN: TVICKERS 2010/10/01 CHKD: HK APPR: DTITUS 2010/10/28 REV: A	QUALITY SYMBOLS ▽=0 ▽C=0	GENERAL TOLERANCES (UNLESS SPECIFIED)		DIMENSION STYLE INCH		SCALE NTS	DESIGN UNITS INCH	THIRD ANGLE PROJECTION	
			mm	INCH	DRAWN BY TVICKERS	DATE 2010/10/01	TITLE STRINGLIGHT 323.25 FT (22) 323@39IN CENTERS 75' LEAD & 180' TAIL		
		4 PLACES	±---	±---	CHECKED BY HK	DATE 2010/10/01	MOLEX INCORPORATED		
		3 PLACES	±---	±.005	APPROVED BY DTITUS	DATE 2010/10/28	DOCUMENT NO. SD-130106-025	SHEET NO. 1 OF 1	
2 PLACES	±0.13	±.010	ANGULAR ±.5°		DRAFT WHERE APPLICABLE MUST REMAIN WITHIN DIMENSIONS		THIS DRAWING CONTAINS INFORMATION THAT IS PROPRIETARY TO MOLEX INCORPORATED AND SHOULD NOT BE USED WITHOUT WRITTEN PERMISSION		
1 PLACE	±0.25	±.020	MATERIAL NO. 1301060165		SIZE A				