

PROTECTION PRODUCTS - RailClamp®

Description

RailClamp® TVS diode arrays are specifically designed to protect sensitive components which are connected to high-speed data and transmission lines from over-voltage caused by **ESD** (electrostatic discharge), **CDE** (Cable Discharge Events), and **EFT** (electrical fast transients).

The unique design incorporates surge rated, low capacitance steering diodes and a TVS diode in a single package. This allows the device to absorb large amounts of energy while protecting downstream components from harmful transient events.

The RClamp®7535M is in a 10-pin MSOP package. The leads are finished with lead-free matte tin. Each device will protect up to eight high-speed lines. They may be used to meet the ESD immunity requirements of IEC 61000-4-2, Level 4 (15kV air, 8kV contact discharge). The combination of small size, low capacitance, and high ESD surge capability makes them ideal for use in applications such as next generation color LCD displays and LVDS interfaces.

Features

- ◆ Transient protection for high-speed data lines to **IEC 61000-4-2 (ESD) ±15kV (air), ±8kV (contact)**
IEC 61000-4-4 (EFT) 40A (5/50ns)
IEC 61000-4-5 (Lightning) 25A (8/20µs)
- ◆ Array of surge rated diodes with internal TVS Diode
- ◆ Small package saves board space
- ◆ Protects up to eight I/O lines
- ◆ Low capacitance (**<5pF**) for high-speed interfaces
- ◆ Low leakage current and clamping voltage
- ◆ Low operating voltage: 2.5V
- ◆ Solid-state silicon-avalanche technology

Mechanical Characteristics

- ◆ JEDEC MSOP-10L package
- ◆ Pb-Free, Halogen Free, RoHS/WEEE Compliant
- ◆ Lead Finish: Matte Sn
- ◆ Molding compound flammability rating: UL 94V-0
- ◆ Marking : Marking code + Date code
- ◆ Packaging : Tape and Reel

Applications

- ◆ LVDS Interfaces
- ◆ LCD TV

Circuit Diagram

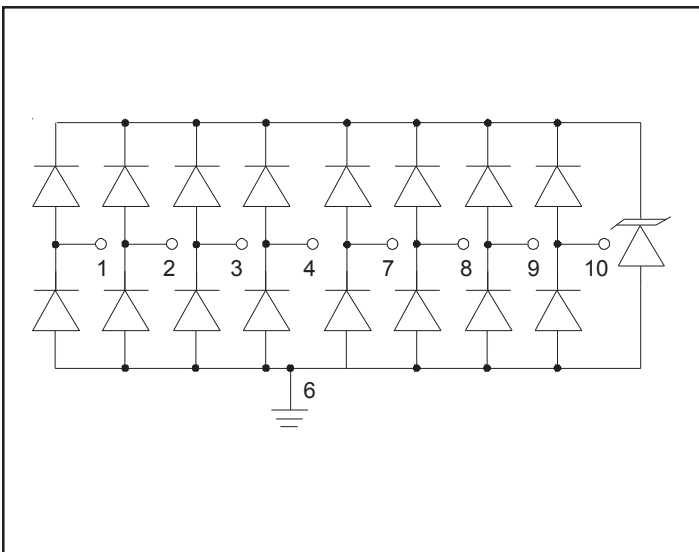

PIN Configuration

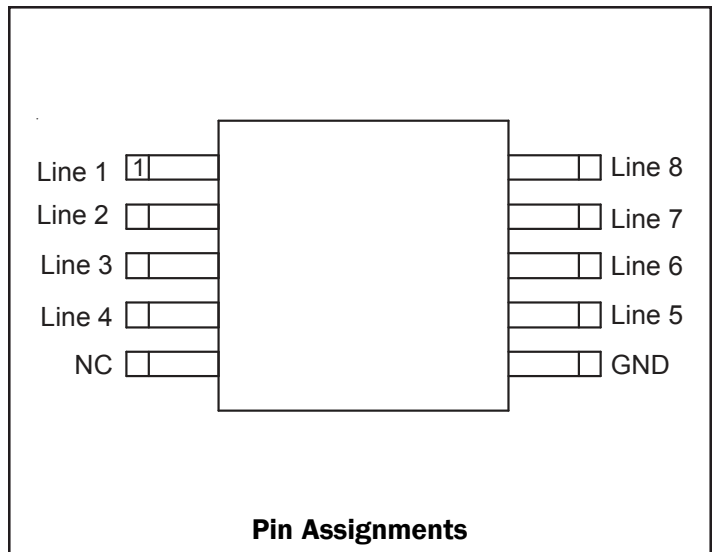

PROTECTION PRODUCTS

Absolute Maximum Rating

Rating	Symbol	Value	Units
Peak Pulse Power (tp = 8/20μs)	P_{pk}	300	Watts
Peak Pulse Current (tp = 8/20μs)	I_{pp}	30	A
ESD per IEC 61000-4-2 (Air) ESD per IEC 61000-4-2 (Contact)	V_{ESD}	25 15	kV
Operating Temperature	T_J	-55 to +125	°C
Storage Temperature	T_{STG}	-55 to +150	°C

Electrical Characteristics (T=25°C)

Parameter	Symbol	Conditions	Minimum	Typical	Maximum	Units
Reverse Stand-Off Voltage	V_{RWM}				2.5	V
Punch-Through Voltage	V_{PT}	$I_{PT} = 2\mu A$ Any I/O to GND	2.7			V
Snap-Back Voltage	V_{SB}	$I_{SB} = 50mA$ Any I/O to GND	2.0			V
Reverse Leakage Current	I_R	$V_{RWM} = 2.5V$, T=25°C Any I/O to GND			0.5	μA
Clamping Voltage	V_C	$I_{pp} = 1A$, $t_p = 8/20\mu s$ Any I/O to GND			4.5	V
Clamping Voltage	V_C	$I_{pp} = 10A$, $t_p = 8/20\mu s$ Any I/O to GND			6.5	V
Clamping Voltage	V_C	$I_{pp} = 25A$, $t_p = 8/20\mu s$ Any I/O to GND			10	V
Junction Capacitance	C_j	Between I/O pins and Ground $V_R = 0V - 2.5V$, f = 1MHz			5	pF
		Between I/O pins $V_R = 0V - 2.5V$, f = 1MHz		2.0		pF

Note 1: I/O pins are pin 1, 2, 3, 4, 7, 8, 9, 10

PROTECTION PRODUCTS

Typical Characteristics

Non-Repetitive Peak Pulse Power vs. Pulse Time

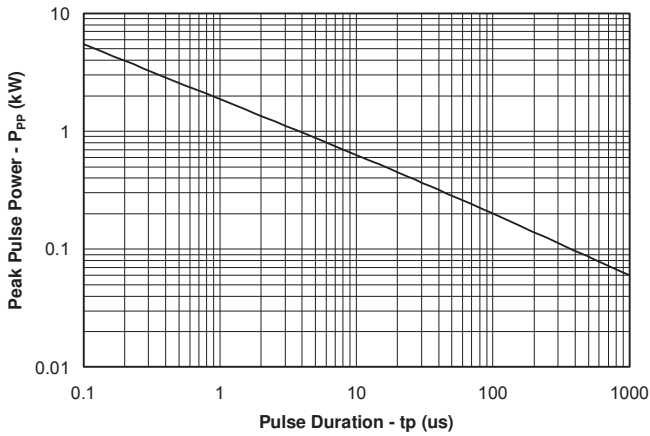

Power Derating Curve

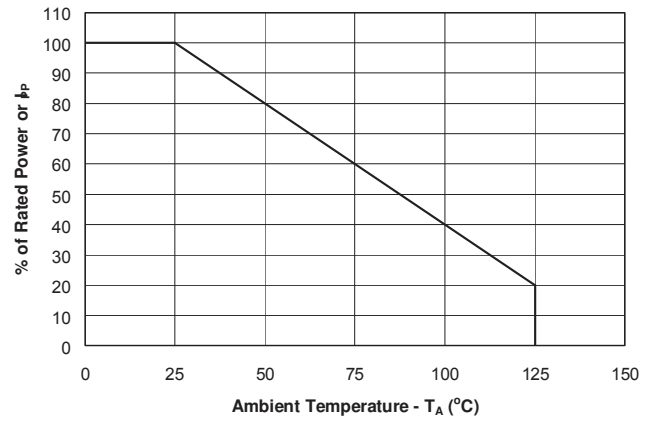

Surge Current Output Waveform (t_p = 8/20μs)

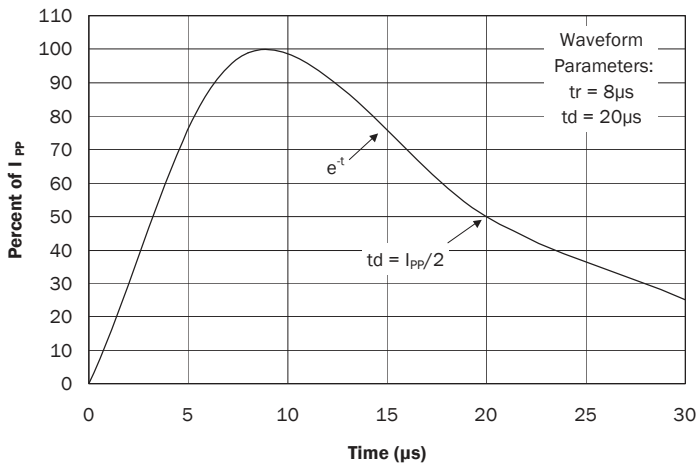

Clamping Voltage vs. Peak Pulse Current Any I/O to GND (t_p = 8/20μs)

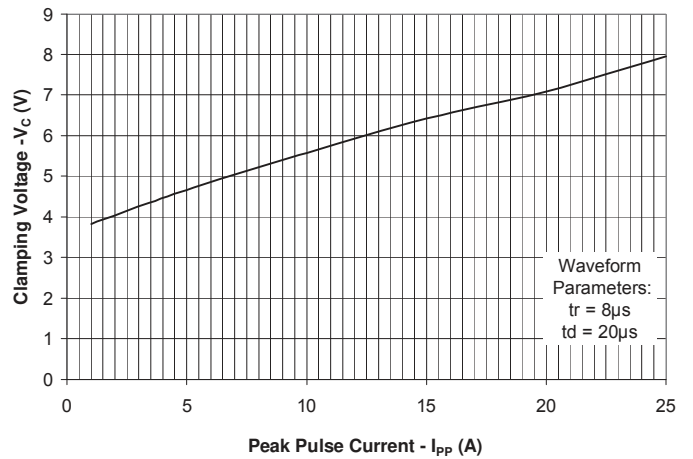

ESD Clamping (8kV Contact per IEC 61000-4-2)

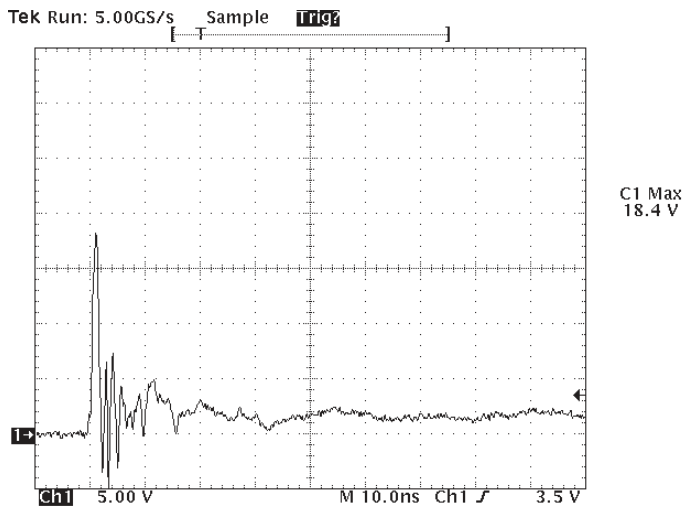

Normalized Capacitance vs. Reverse Voltage

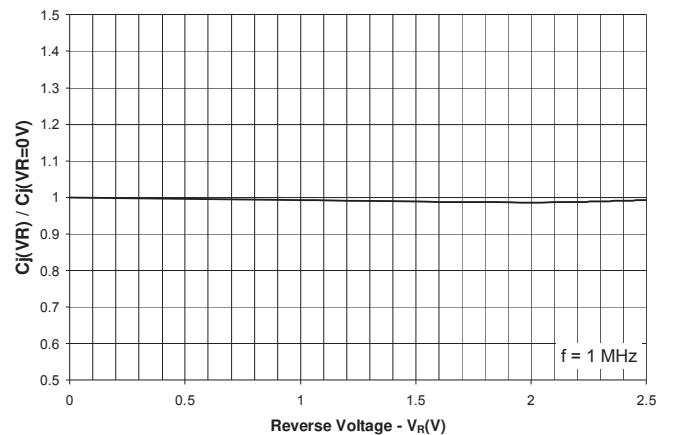

Note: Data is taken with a 10x attenuator

PROTECTION PRODUCTS

Typical Characteristics

Insertion Loss S21 (I/O to Gnd)

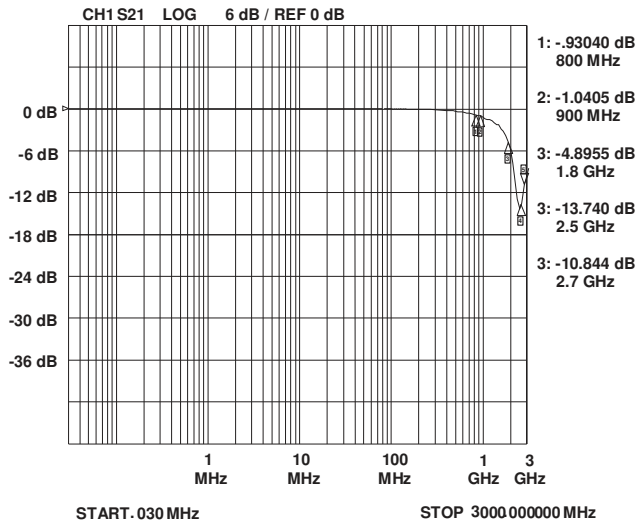

Insertion Loss S21 (I/O to I/O)

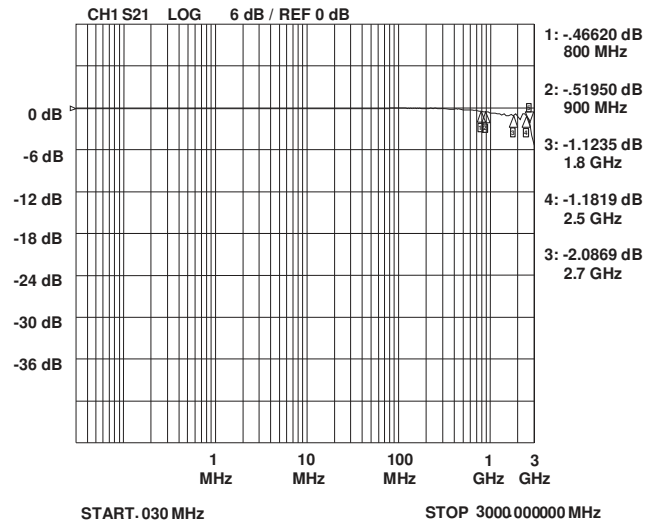

Analog Crosstalk

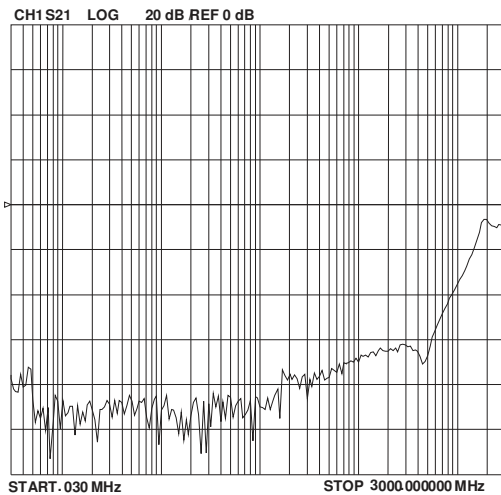

PROTECTION PRODUCTS

Applications Information

Device Connection Options for Protection of Eight High-Speed Data Lines

This device is designed to protect high-speed data lines. When the voltage on the protected line exceeds the breakdown voltage of the internal TVS diode, the steering diodes are forward biased, conducting the transient current away from the sensitive circuitry to ground.

Data lines are connected at pins 1 - 4 and 7 - 10. Pin 6 should be connected directly to a ground plane. The path length is kept as short as possible to minimize parasitic inductance. When configured as shown, a LVDS chip may withstand up to 10A for a 2/10 us impulse waveform.

The RClamp7535M is constructed using Semtech's proprietary EPD process technology. The EPD process provides low stand-off (turn-on) voltages with significant reductions while maintaining good clamping characteristics and high surge capability. They feature a true operating voltage of 2.5 volts. The characteristics of the RClamp7535M eliminate the need to add an external resistor for protection of LVDS interfaces.

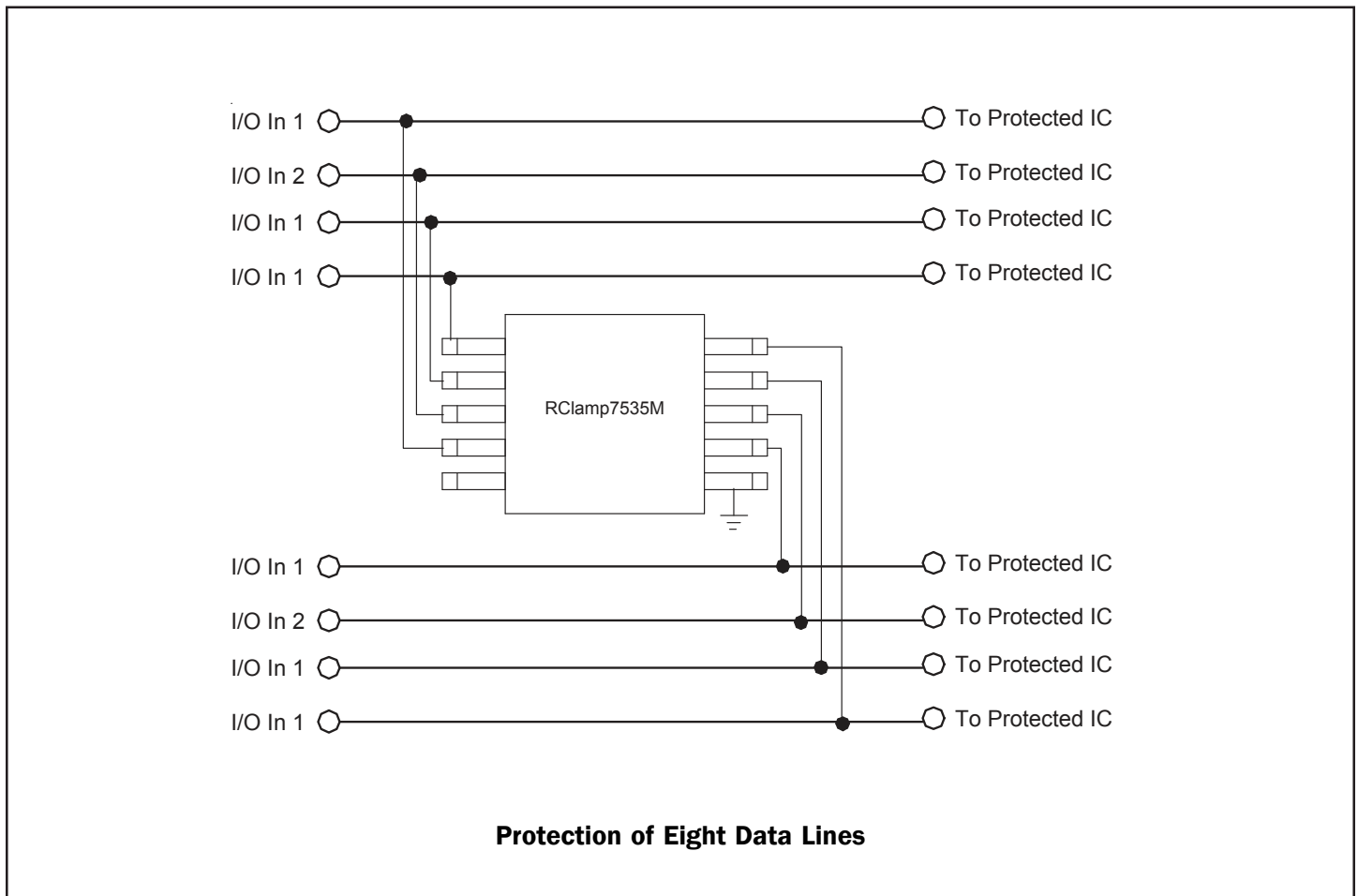

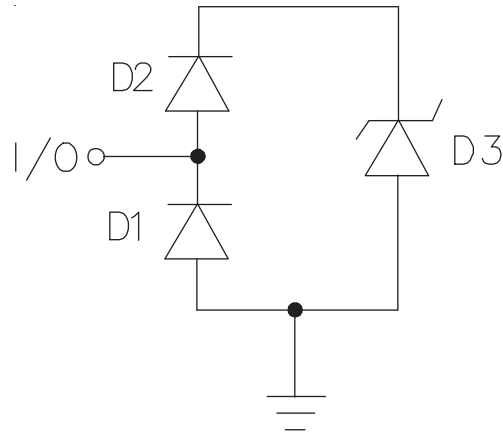

Spice Model

RClamp7535M Spice Parameters				
Parameter	Unit	D1 (LCRD)	D2 (LCRD)	D3 (TVS)
IS	Amp	1E-20	1E-20	1.66E-13
BV	Volt	100	100	2.89
VJ	Volt	0.72	0.67	0.53
RS	Ohm	0.329	0.241	0.06
IBV	Amp	1E-3	1E-3	1E-3
CJO	Farad	1.7E-12	1.7E-12	288E-12
TT	sec	2.541E-9	2.541E-9	2.541E-9
M	--	0.01	0.01	0.17
N	--	1.1	1.1	1.1
EG	eV	1.11	1.11	1.11

PROTECTION PRODUCTS

Outline Drawing - MSOP-10L

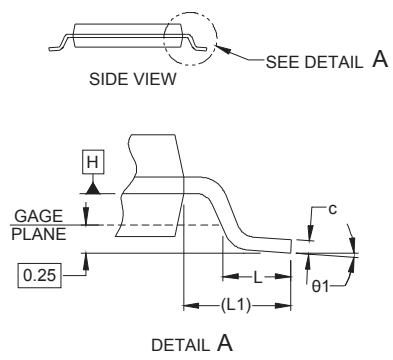
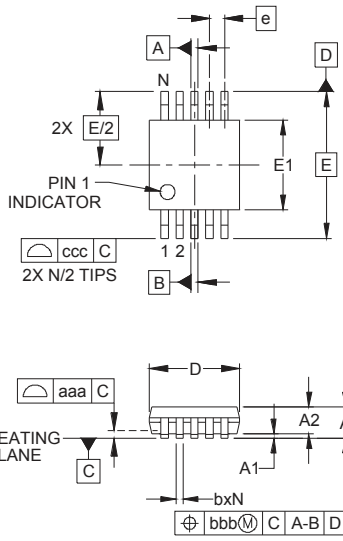

DIM	INCHES			MILLIMETERS		
	MIN	NOM	MAX	MIN	NOM	MAX
A	-	-	.043	-	-	1.10
A1	.000	-	.006	0.00	-	0.15
A2	.030	-	.037	0.75	-	0.95
b	.007	-	.011	0.17	-	0.27
c	.003	-	.009	0.08	-	0.23
D	.114	.118	.122	2.90	3.00	3.10
E1	.114	.118	.122	2.90	3.00	3.10
E	.193 BSC			4.90 BSC		
e	.020 BSC			0.50 BSC		
L	.016	.024	.032	0.40	0.60	0.80
L1	(.037)			(.95)		
N	10			10		
theta1	0°	-	8°	0°	-	8°
aaa	.004			0.10		
bbb	.003			0.08		
ccc	.010			0.25		

NOTES:

1. CONTROLLING DIMENSIONS ARE IN MILLIMETERS (ANGLES IN DEGREES).
2. DATUMS [-A-] AND [-B-] TO BE DETERMINED AT DATUM PLANE [-H-]
3. DIMENSIONS "E1" AND "D" DO NOT INCLUDE MOLD FLASH, PROTRUSIONS OR GATE BURRS.
4. REFERENCE JEDEC STD MO-187, VARIATION BA.

Land Pattern - MSOP-10L

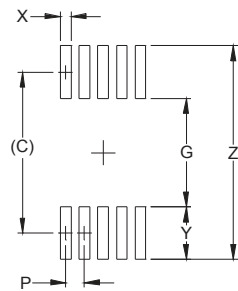

DIM	DIMENSIONS	
	INCHES	MILLIMETERS
C	(.161)	(4.10)
G	.098	2.50
P	.020	0.50
X	.011	0.30
Y	.063	1.60
Z	.224	5.70

NOTES:

1. THIS LAND PATTERN IS FOR REFERENCE PURPOSES ONLY. CONSULT YOUR MANUFACTURING GROUP TO ENSURE YOUR COMPANY'S MANUFACTURING GUIDELINES ARE MET.

PROTECTION PRODUCTS

Marking



YYWW = Date Code

Ordering Information

Part Number	Lead Finish	Qty per Reel	Reel Size
RClamp7535M.TLT	Matte Sn	3000	13 Inch

RailClamp and RClamp are marks of Semtech Corporation

Tape and Reel Specification

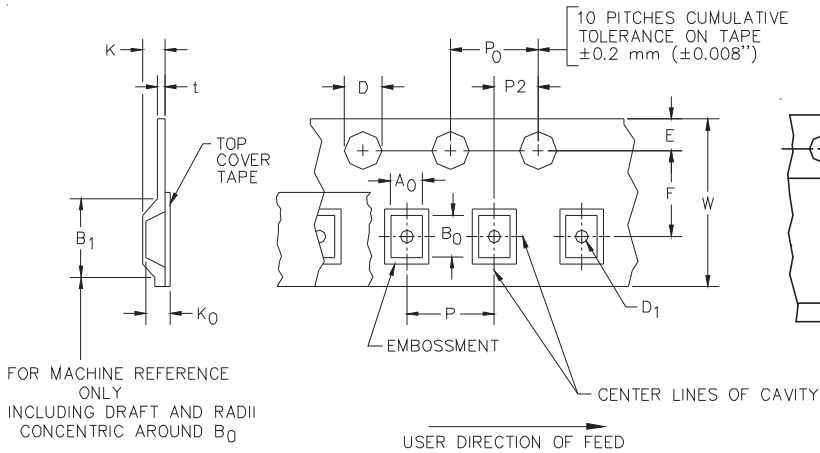

Device Orientation in Tape

A0	B0	K0
5.30 +/-0.20 mm	3.40 +/-0.20 mm	1.40 +/-0.10 mm

Tape Width	B, (Max)	D	D1	E	F	K (MAX)	P	P0	P2	T(MAX)	W
12 mm	8.2 mm	1.5 + 0.1 mm - 0.0 mm)	0.5 mm ±0.05	1.750±.10 mm	5.5±0.05 mm	4.5 mm	8.0±0.1 mm	4.0±0.1 mm	2.0±0.05 mm	0.4 mm	12.0 mm ± 0.3 mm

Contact Information

Semtech Corporation
 Protection Products Division
 200 Flynn Rd., Camarillo, CA 93012
 Phone: (805)498-2111 FAX (805)498-3804