

Secondary Side Average Current Mode Controller

FEATURES

- Practical Secondary Side Control of Isolated Power Supplies
- Provides a Self Regulating Bias Supply From a High Input Voltage Using an External N-Channel Depletion Mode FET
- Onboard Precision, Fixed Gain, Differential Current Sense Amplifier
- Wide Bandwidth Current Error Amplifier
- 5V Reference
- High Current, Programmable Gm Amplifier Optimized to Drive Opto-couplers

DESCRIPTION

The UCC3839 provides the control functions for secondary side average current mode control in isolated power supplies. Start up, pulse width modulation and MOSFET drive must be accomplished independently on the primary side. Communication from secondary to primary side is anticipated through an opto-isolator.

Accordingly, the UCC3839 contains a fixed gain current sense amplifier, voltage and current error amplifiers, and a Gm type buffer/driver amplifier for the opto-isolator. Additional housekeeping functions include a precision 5V reference and a bias supply regulator.

Power for the UCC3839 can be generated by peak rectifying the voltage of the secondary winding of the isolation transformer. From this unregulated voltage, the UCC3839's bias supply regulator will generate its own 7.5V bias supply using an external, N-channel, depletion mode FET.

The UCC3839 can be configured for traditional average current mode control where the output of the voltage error amplifier commands the current error amplifier. It can also be configured for output voltage regulation with average current mode short circuit current limiting, employing two parallel control loops regulating the output voltage and output current independently.

BLOCK DIAGRAM

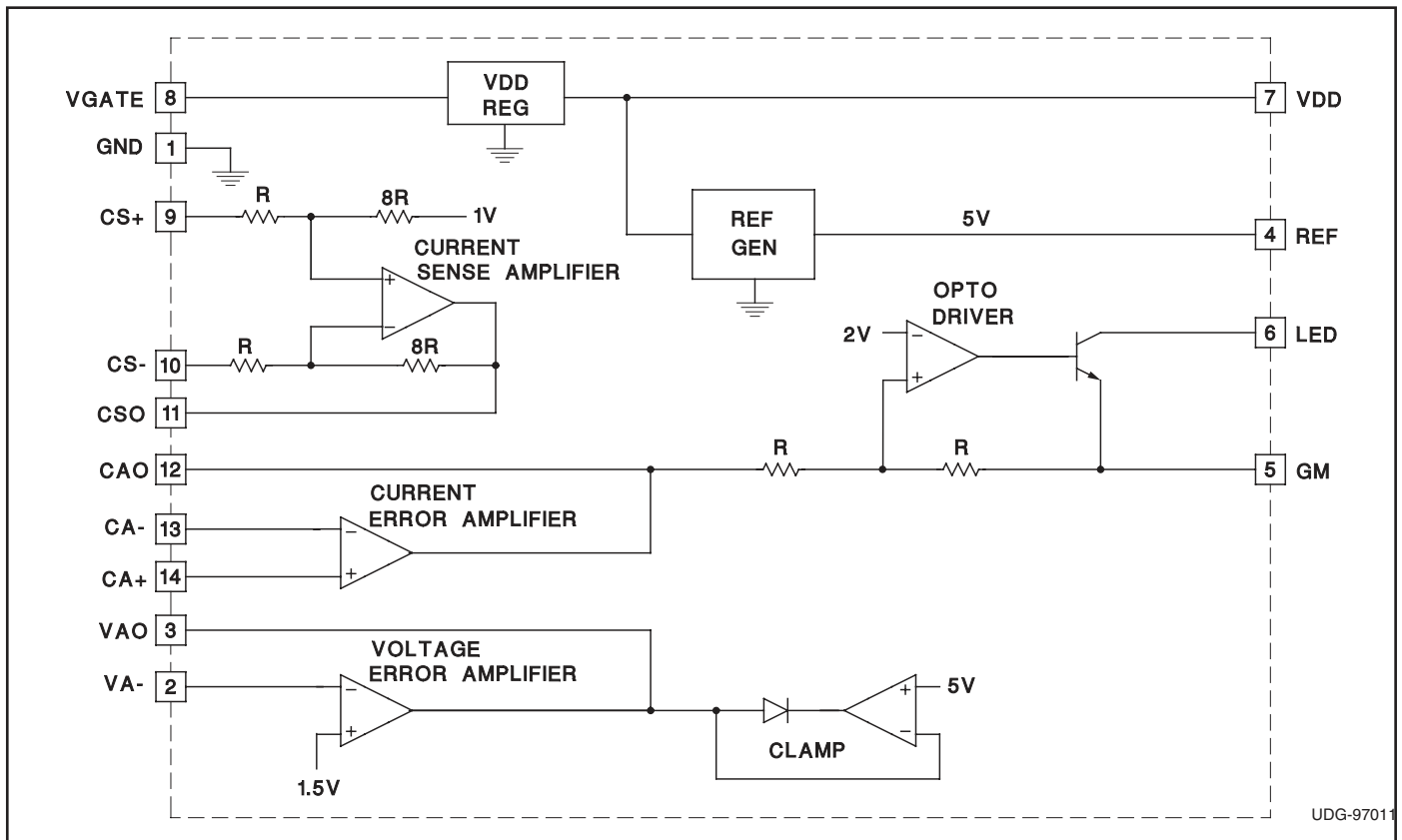

ABSOLUTE MAXIMUM RATINGS

Supply Voltage	15V
Supply Current	
(LED not connected)	2mA
(LED connected)	14mA
Analog Inputs	-0.3V to 15V
Power Dissipation at TA = 60°C	
(LED not connected)	20mW
(LED connected)	55mW
Storage Temperature	-65°C to +150°C
Junction Temperature	-55°C to +150°C
Lead Temperature (Soldering, 10sec.)	+300°C

Currents are positive into, negative out of the specified terminal.
Consult Packaging Section of Databook for thermal limitations and considerations of package.

CONNECTION DIAGRAMS

DIL-14, SOIC-14 (Top View)
D or N Package

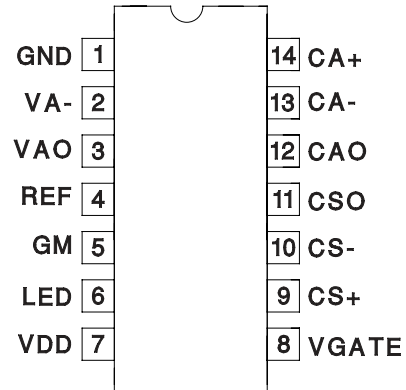

ELECTRICAL CHARACTERISTICS: Unless otherwise specified, 0°C to 70°C for the UCC3839, -40°C to 85° for the UCC2839. V_{LINE} = 10V, R_G = 400Ω. T_A = T_J.

PARAMETER	TEST CONDITIONS	MIN	TYP	MAX	UNITS
Current Error Amplifier					
V _{IO}				10	mV
AVOL		60			dB
CMRR	V _{CM} = 0.5V to 5.5V	60			dB
PSRR	V _{LINE} = 10V to 20V	60			dB
CAO High	CA- = 1V, CA+ = 1.1V, I _{CAO} = -100μA	4.8		7	V
I _{CAO}	CA- = 1V, CA+ = 1.1V, CAO = 0.5V	-500		-250	μA
CAO Low	CA- = 1V, CA+ = 0.9V, I _{CAO} = 500μA		0.2	0.4	V
GBW	F = 100kHz, T _A = 25°C	3	5		MHz
Voltage Error Amplifier					
VA-		1.46	1.5	1.525	V
AVOL		60			dB
PSRR	V _{LINE} = 10V to 20V	60			dB
VAO High	I _{VAO} = -100μA to 100μA	4.8	5	5.2	V
I _{VAO}	VA- = 1.45V, VAO = 0.5V	-500		-250	μA
VAO Low	VA- = 1.55V, VAO = 0.5V, I _{VAO} = 500μA		0.2	0.4	V
GBW	(Note 1)	3	5		MHz
Current Sense Amplifier					
CSO Zero	CS+ = CS- = -0.3V to 5.5V, I _{CSO} = -100μA to 100μA	0.85	1	1.15	V
AV	CS+ = 0, CS- = 0mV to -200mV	7.75	8	8.2	V/V
Current Sense Amplifier (cont.)					
Slew Rate	CS+ = 0, CS- = 0mV to -0.5V	2	4		V/μs
CSO	CS+ = -200mV, CS- = -700mV	4.75	5	5.2	V
LED Driver					
I _{LED}	LED = 5.5V, CA- = 1V, CA+ = 1.1V, R _G = 400		0	10	μA
	LED = 5.5V, CA- = 1V, CA+ = 0.9V, R _G = 400	9	10	11	mA
G _m	LED = 5.5V, CAO = 1V to 3V, R _G = 400	2.25	2.5	2.75	mS
Slew Rate	CAO = 2V to 2.5V, LED = 400Ω to 5.5V, R _G = 400	1	4		V/μs

ELECTRICAL CHARACTERISTICS: Unless otherwise specified, 0°C to 70°C for the UCC3839, –40°C to 85° for the UCC2839. $V_{LINE} = 10V$, $R_G = 400\Omega$. $T_A = T_J$.

PARAMETER	TEST CONDITIONS	MIN	TYP	MAX	UNITS
Precision Reference					
REF	$T_J = 25^\circ C$	4.94	5	5.06	V
	$I_{REF} = 0mA \text{ to } 1mA$, $V_{LINE} = 10V \text{ to } 20V$	4.9		5.1	V
VA+/REF		0.298	0.3	0.302	V/V
VDD Regulator					
VDD	$I_{DD} = 0mA \text{ to } -15mA$, $V_{LINE} = 10V \text{ to } 40V$	7	7.5	8	V
IVDD	$V_{LINE} = 10V \text{ to } 40V$, $CA- = 0V$, $CA+ = 1V$, $VA- = 2.9V$, $CS+ = CS- = 0$, $I_{REF} = 0$		1.3	2	mA

Note 1: Ensured by design. Not 100% tested in production.

PIN DESCRIPTIONS

CA–: Current Error Amplifier Negative Input.

CAO: Current Error Amplifier Output. Output source current is limited, and output sink current is guaranteed to be greater than the VAO output source current. Current loop compensation components are generally connected to CAO and CA–.

CA+: Current Error Amplifier Positive Input.

CS–: Current Sense Amplifier Negative Input.

CSO: Current Sense Amplifier Output. Internally set gain $V_{OUT}/V_{IN} = 8$ $V_{IN} = 0V$ results in $CSO = 1V$.

CS+: Current Sense Amplifier Positive Input.

GM: Gm (transconductance) Programming Pin. Resistor $R_{GM} = 400\Omega$ to GND.

GND: Chip Ground.

LED: Output of LED Driver. Connect LED from VDD pin to LED.

REF: 5V Precision Reference Buffer Output. Minimum Decoupling Capacitance = 0.01 μ F

VA–: Voltage Error Amplifier Negative Input. Voltage Error Amplifier is internally referenced to 1.5V

VAO: Voltage Error Amplifier Output. In a two loop average current mode control configuration, VAO is connected to CA+ and is the current command signal. VAO is internally clamped not to exceed 5V for short circuit control. In a single loop voltage mode control configuration with a parallel average short circuit current control loop, VAO is connected directly to CAO. Output source current is limited, and output sink current is guaranteed to be greater than the CAO output source current.

VDD: 7.5V Regulator output. Supply for most of the chip. Minimum Decoupling Capacitance = 0.01 μ F

VGATE: External FET Gate Control Voltage.

APPLICATION INFORMATION

Fig. 1 shows a typical secondary side average current mode controller configuration using the UCC3839. In this configuration, output voltage is sensed and regulated by the voltage error amplifier. Its output, VAO provides the reference for the current error amplifier at the CA+ pin. VAO can be connected to CA+ directly or through a resistive divider depending on the particular application requirements.

Average current mode control needs accurate output current information which is provided by a low value current sense resistor. The voltage proportional to the converter's output current is sensed and amplified by the

precision current sense amplifier of the chip. The onboard current sense amplifier has a gain of 8 and is intended for differential sensing of the shunt voltage with a common mode voltage range from 0V up to 5V. The output of the current sense amplifier, CSO is 1V for zero input which guarantees that the circuit can control currents down to 0A.

The CSO signal is fed to the CA– input of the current error amplifier through a resistor. The current error amplifier takes the VAO and CSO signals and generates the error signal for the pulse width modulator.

APPLICATION INFORMATION (cont.)

Since the PWM function is located on the primary side of the power converter the CAO signal must be sent across the safety isolation boundary. The UCC3839 anticipates an opto-coupler to provide isolation between primary and secondary. Therefore, CAO drives a transconductance amplifier that controls LED current in an opto-isolator. During start up and when CAO exceeds 4V, the current in the LED drops to zero. Maximum LED current is obtained during normal operation as CAO reaches its lowest potential. Its value is determined by the programming resistor value from the GM pin to circuit GND.

An alternative secondary side controller configuration is introduced in Fig. 2. In this circuit, the voltage and current control loops of the UCC3839 are connected parallel. It can be achieved by connecting the VAO and CAO pins together. The error amplifier with the lower output voltage

controls the current in the opto-coupler providing the feedback signal for the PWM section on the primary side. Voltage regulation is still maintained by the voltage error amplifier until a user programmable output current is reached. At this time CAO will take control over the Gm amplifier and the output current of the converter will be regulated while the output voltage falls below its nominal value. This current level is set at the CA+ input by a resistive divider from the 5V reference of the chip.

Since the chip is powered from a peak rectifier which maintains the bias supply for the UCC3839 even under short circuit conditions, both of these techniques can be used to eliminate the short circuit runaway problem in isolated power supplies using peak current mode control on the primary side.

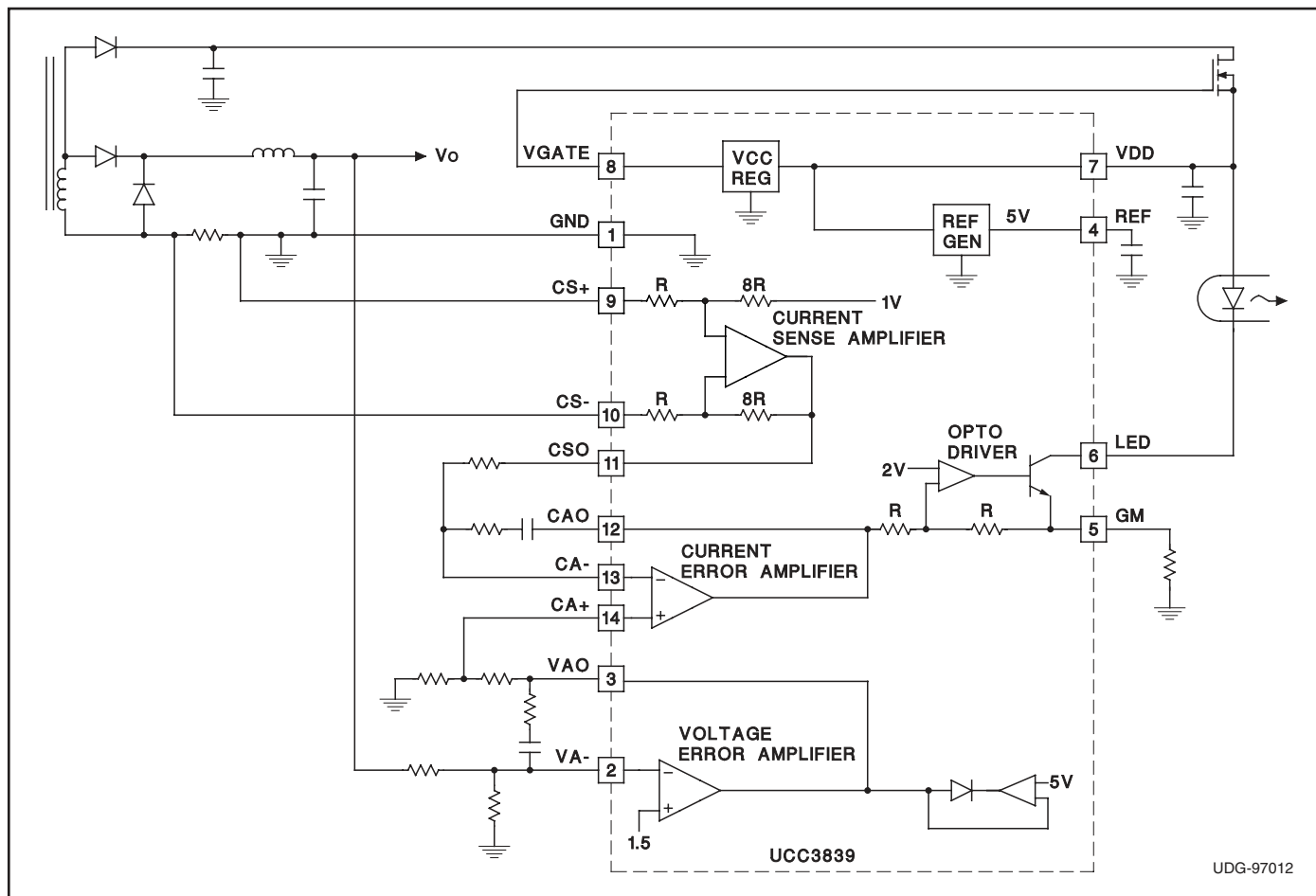

Figure 1. Secondary side average current mode controller.

APPLICATION INFORMATION (cont.)

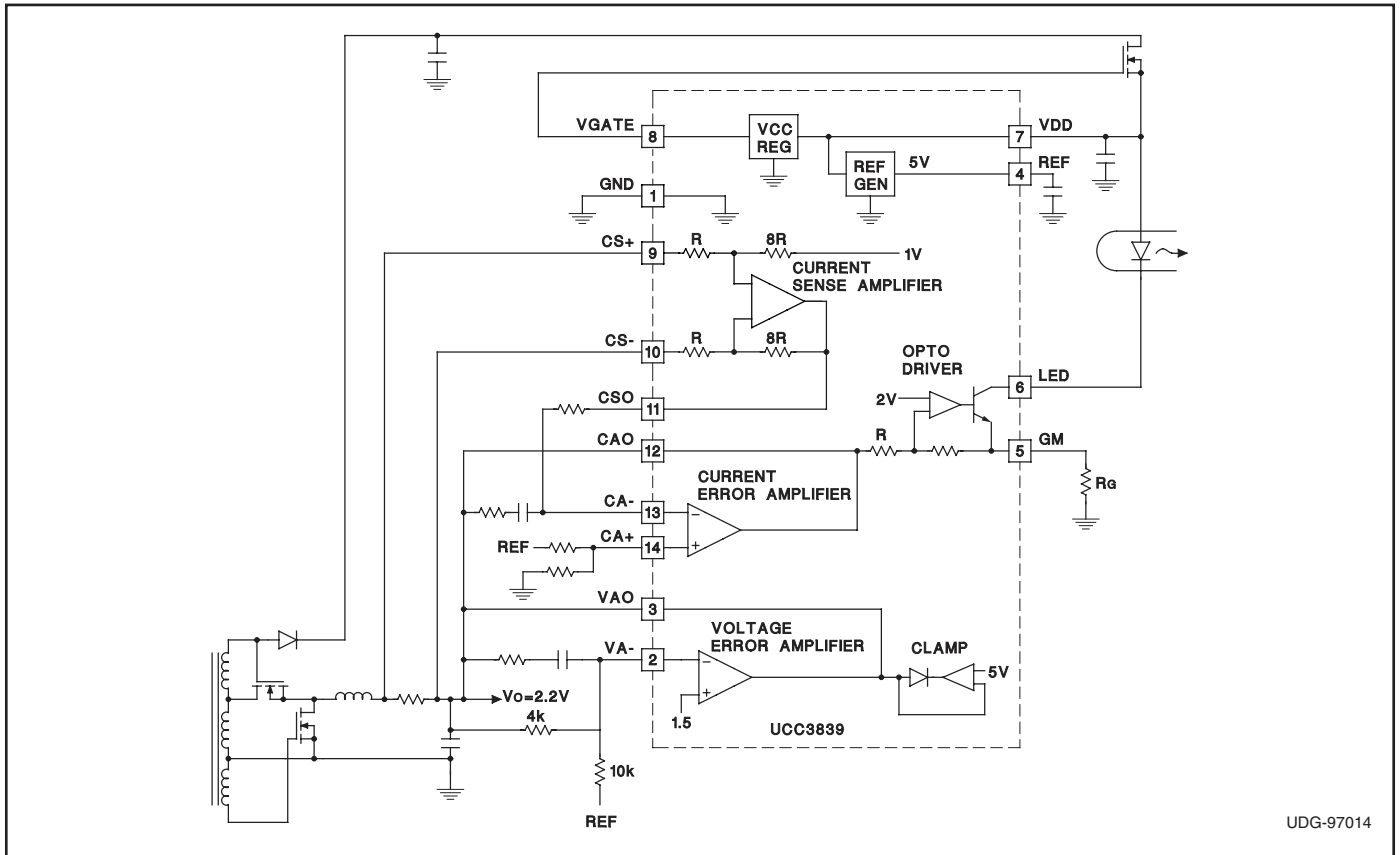

Figure 2. Voltage mode with average current short circuit limit.

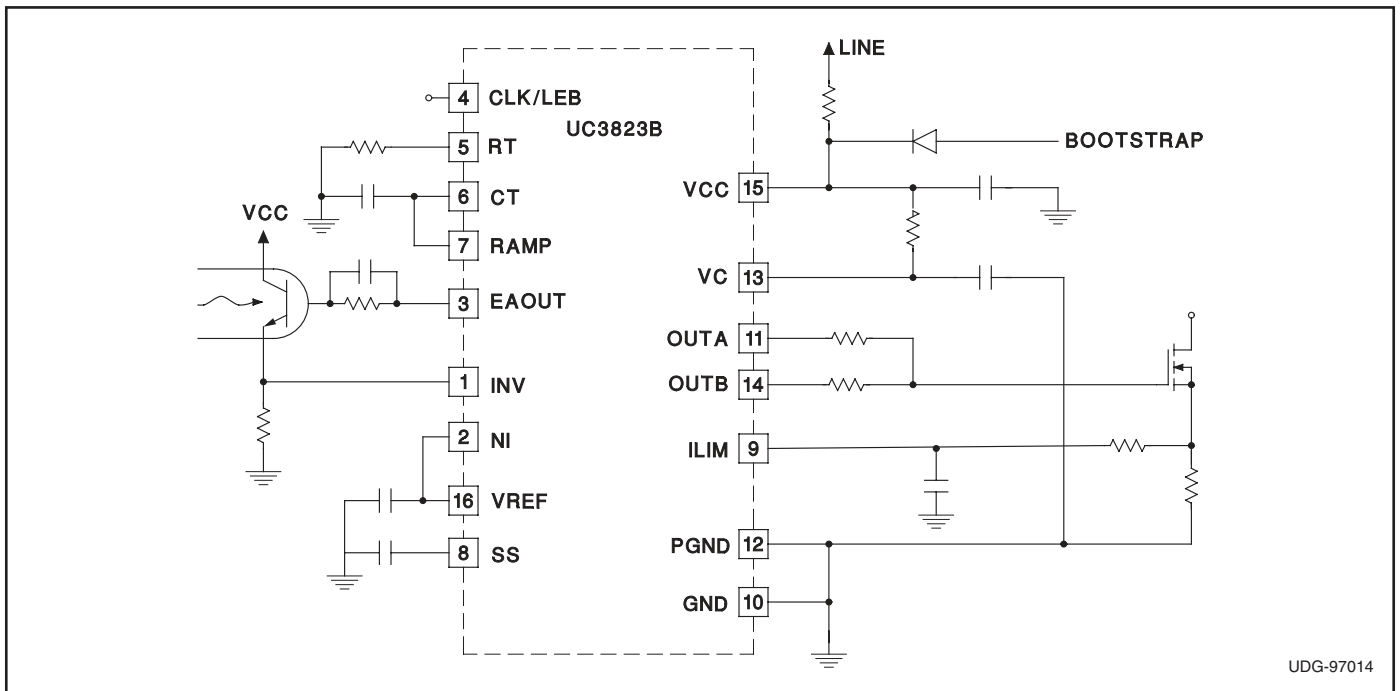

Figure 3. Typical primary side circuit for use with secondary side average current mode controller.

PACKAGING INFORMATION

Orderable Device	Status ⁽¹⁾	Package Type	Package Drawing	Pins	Package Qty	Eco Plan ⁽²⁾	Lead/Ball Finish	MSL Peak Temp ⁽³⁾
UCC2839D	ACTIVE	SOIC	D	14	50	Green (RoHS & no Sb/Br)	CU NIPDAU	Level-2-260C-1 YEAR
UCC2839DTR	ACTIVE	SOIC	D	14	2500	Green (RoHS & no Sb/Br)	CU NIPDAU	Level-2-260C-1 YEAR
UCC2839DTRG4	ACTIVE	SOIC	D	14	2500	Green (RoHS & no Sb/Br)	CU NIPDAU	Level-2-260C-1 YEAR
UCC2839N	ACTIVE	PDIP	N	14	25	Green (RoHS & no Sb/Br)	CU NIPDAU	N / A for Pkg Type
UCC2839NG4	ACTIVE	PDIP	N	14	25	Green (RoHS & no Sb/Br)	CU NIPDAU	N / A for Pkg Type
UCC3839D	ACTIVE	SOIC	D	14	50	Green (RoHS & no Sb/Br)	CU NIPDAU	Level-2-260C-1 YEAR

⁽¹⁾ The marketing status values are defined as follows:

ACTIVE: Product device recommended for new designs.

LIFEBUY: TI has announced that the device will be discontinued, and a lifetime-buy period is in effect.

NRND: Not recommended for new designs. Device is in production to support existing customers, but TI does not recommend using this part in a new design.

PREVIEW: Device has been announced but is not in production. Samples may or may not be available.

OBSOLETE: TI has discontinued the production of the device.

⁽²⁾ Eco Plan - The planned eco-friendly classification: Pb-Free (RoHS), Pb-Free (RoHS Exempt), or Green (RoHS & no Sb/Br) - please check <http://www.ti.com/productcontent> for the latest availability information and additional product content details.

TBD: The Pb-Free/Green conversion plan has not been defined.

Pb-Free (RoHS): TI's terms "Lead-Free" or "Pb-Free" mean semiconductor products that are compatible with the current RoHS requirements for all 6 substances, including the requirement that lead not exceed 0.1% by weight in homogeneous materials. Where designed to be soldered at high temperatures, TI Pb-Free products are suitable for use in specified lead-free processes.

Pb-Free (RoHS Exempt): This component has a RoHS exemption for either 1) lead-based flip-chip solder bumps used between the die and package, or 2) lead-based die adhesive used between the die and leadframe. The component is otherwise considered Pb-Free (RoHS compatible) as defined above.

Green (RoHS & no Sb/Br): TI defines "Green" to mean Pb-Free (RoHS compatible), and free of Bromine (Br) and Antimony (Sb) based flame retardants (Br or Sb do not exceed 0.1% by weight in homogeneous material)

⁽³⁾ MSL, Peak Temp. -- The Moisture Sensitivity Level rating according to the JEDEC industry standard classifications, and peak solder temperature.

Important Information and Disclaimer:The information provided on this page represents TI's knowledge and belief as of the date that it is provided. TI bases its knowledge and belief on information provided by third parties, and makes no representation or warranty as to the accuracy of such information. Efforts are underway to better integrate information from third parties. TI has taken and continues to take reasonable steps to provide representative and accurate information but may not have conducted destructive testing or chemical analysis on incoming materials and chemicals. TI and TI suppliers consider certain information to be proprietary, and thus CAS numbers and other limited information may not be available for release.

In no event shall TI's liability arising out of such information exceed the total purchase price of the TI part(s) at issue in this document sold by TI to Customer on an annual basis.