

THIS DRAWING IS UNPUBLISHED. RELEASED FOR PUBLICATION
 © COPYRIGHT - TE Connectivity Ltd. ALL RIGHTS RESERVED.

REVISIONS				
P	LTR	DESCRIPTION	DATE	APVD
E1		REVISED PER ECO-19-014709	25SEP2019	AP GL

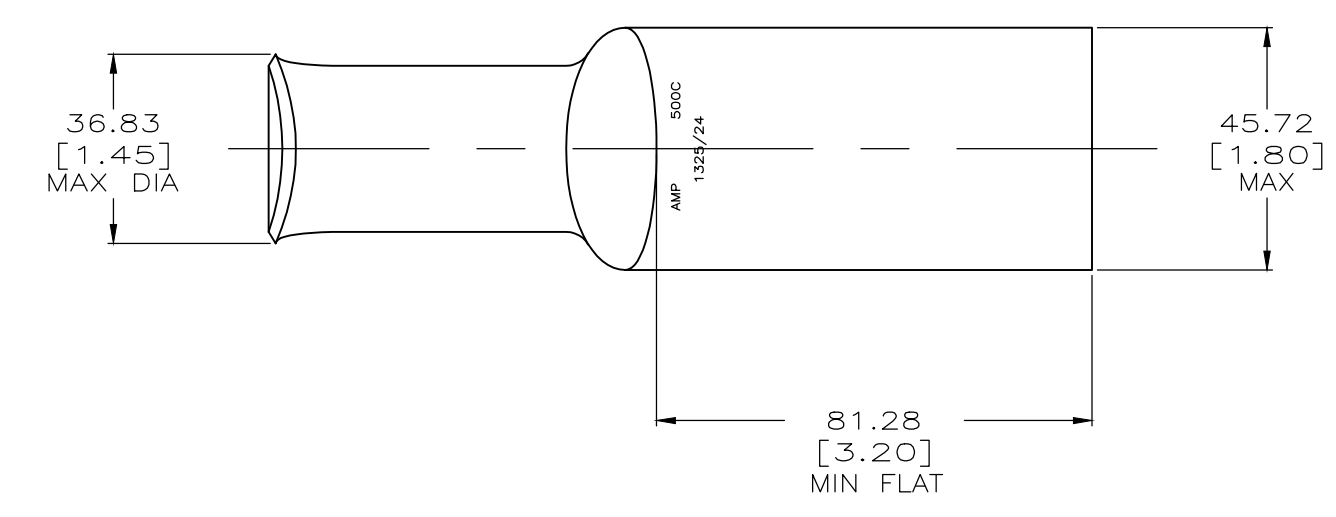

- 1 CIRCULAR MIL RANGE: 450-550 MCM
- 2 TIN PL 0.00381[.000150] MIN THK PER MIL-T-10727

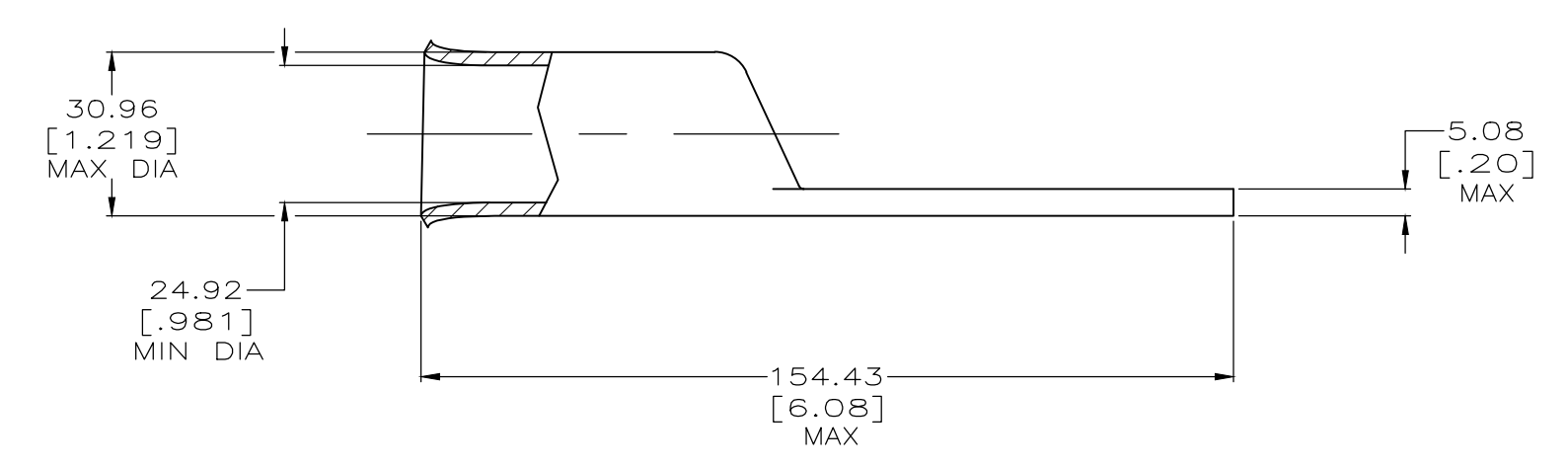

326123
PART NO

THIS DRAWING IS A CONTROLLED DOCUMENT.		DWN DK SCHRUM 02/28/90	STE TE Connectivity	
DIMENSIONS: mm [INCHES]		CHK MS FEHER 24JAN95		
TOLERANCES UNLESS OTHERWISE SPECIFIED:		APVD WJ VOCKROTH 24JAN95	NAME	
0 PLC ± -		PRODUCT SPEC	TERMINAL, AMPPOWER,™	
1 PLC ± -		108-30200	WIRE SIZE: 500 MCM	
2 PLC ± 0.51[.020]		APPLICATION SPEC	-	
3 PLC ± -		SIZE	CAGE CODE	DRAWING NO
4 PLC ± -		—	A3	00779
ANGLES ± -		WEIGHT	C-326123	
FINISH		.622 LB	RESTRICTED TO	
MATERIAL		CUSTOMER DRAWING	SCALE	SHEET
ANNEALED COPPER ASTM B-75			NTS	1 OF 1
2				REV E1

