

## 4.7V to 17V Input, 5A Synchronous Buck Regulators with AOT Control

### Features

- Wide VIN Range: 4.7V to 17V
- Maximum Continuous Output Current: 5A
- Factory fixed Options for Output Voltage from 0.64V to 5.5V with 40mV step, available by request
- Integrated High / Low-Side FETs (65mΩ / 35mΩ)
- Advanced Adaptive On-Time Control
- Fast Transient Response
- Open Drain Power Good Indicator
- ±0.5% Feedback Voltage Reference
- Zero Shutdown Supply Current
- 50μA Non-Switching Operating Quiescent Current
- 80μA No Load Operating Quiescent Current
- High Efficiency in Light Load and Heavy Load.
- Factory 300kHz, 500kHz, 800kHz, and 1MHz Switching Frequency options available by request
- Internal Soft-Start
- Factory Forced CCM (FCCM) or automatic CCM/PFM (Auto-Skip) Options
- Active discharge Mode option
- Built-in Cycle-by-Cycle Current Limit, Short Circuit Protection, Input UVLO, Output Under-Voltage Protection, Output Over-Voltage Protection, and Thermal Shutdown Protection
- Small 20-bump WLCSP (1.7mm x 2.0mm) Package

### Applications

- CPU, GPU, AP, DSP, FPGA, VIO, VSYS
- HDD, LPDDR3, LPDDR4 Memory Power
- Tablets, Netbooks, Ultra-Books, Mobile Internet Devices, IoT, and Server.
- DSC, Drones, Gaming Consoles, TV Set Box

### Description

KTB8370 is 5A, 17V synchronous buck regulators with integrated high-side and low-side power FETs. The device operates over a wide input voltage range to support a variety of applications with input voltage from regulated 5V and 12V power rails and multicell batteries.

KTB8370 employs Kinetics' proprietary advanced adaptive on-time (AOT) control for fast transient response and high output voltage accuracy. This control technique eliminates external loop compensation network and allows the use of ceramic output capacitors without ripple-generating circuitry. These features enable very small total solution size and make KTB8370 easy to use.

The device features an internal soft-start function to limit inrush current during start-up. The device has comprehensive built-in protection features including input voltage UVLO, high-side cycle-by-cycle peak current limit, low-side valley current limit, reverse current protection, short-circuit protection, output over-voltage protection, and thermal shutdown.

KTB8370 are available in RoHS and Green compliant 20-bump 1.7mm x 2.0mm x 0.6mm wafer-level chip-scale WLCSP20 package.

### Typical Application Schematic

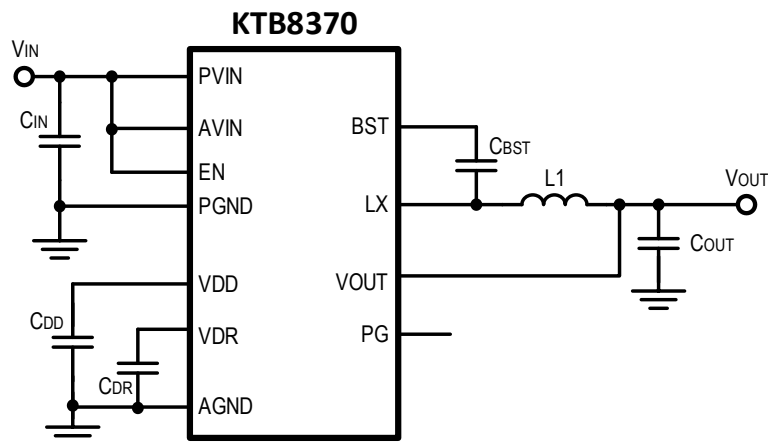

## Pin Descriptions

Pin #	Pin Name	Function
A1, A2, A3, A4	PGND	Power ground for buck regulator.
B1, B2, B3, B4	LX	Inductor connection for buck regulator.
C1, C2, C3, C4	PVIN, AVIN	Input Voltage Power and Sense Pins for buck regulator. Connect to a power rail ranges from 4.7V to 17V.
D1	BST	Boost capacitor for charge pump gate driver.
D2	NC	NC Pin, must be tied to AGND.
D3	EN	Chip enable logic input.
D4	VDR	Power stage driver voltage.
E1	VOUT	Output voltage sense input.
E2	PG	Open-drain Power Good Indicator Output. Connect a pull-up resistor between PG pin and VDD pin, a resistor ranges from 10kΩ to 100kΩ is recommended. This pin is pulled to ground when the output voltage is outside of its specified threshold. If not used, tie to AGND or PGND.
E3	VDD	Analog circuit bias voltage.
E4	AGND	Analog ground for analog circuit.

## Pinout Diagram

### WLCSP45-20

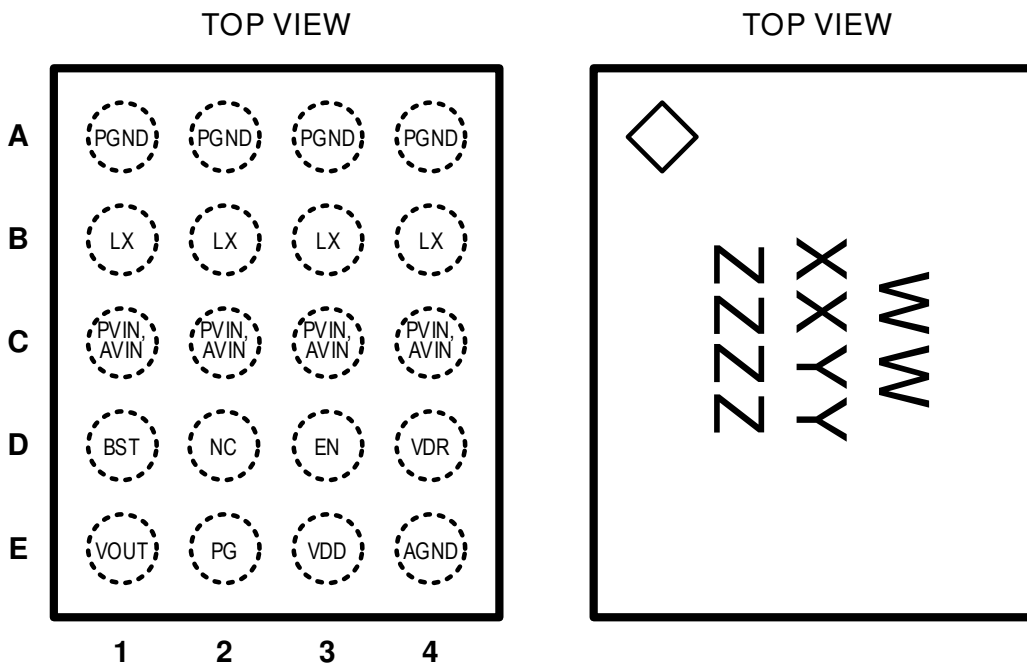

**20-Bump 1.750mm x 2.063mm x 0.620mm  
WLCSP Package**

Top Mark

WW = Device ID Code, XX = Date Code  
YY = Assembly Code, ZZZZ = Serial Number

## Absolute Maximum Ratings<sup>1</sup>

(T<sub>A</sub> = 25°C unless otherwise noted)

Description		Value	Units
PVIN to PGND		-0.3 to 18	V
PGND to AGND		-0.3 to 0.3	V
LX to PGND		-0.3 to (PVIN +0.3)	V
BST to LX		-0.3 to 5.5	V
VOUT, VDD, VDR, EN, and PG to AGND		-0.3 to 5.5	V
LX	Continuous Current	7	A <sub>RMS</sub>
	Peak Current (2.5ms maximum)	10	A <sub>PEAK</sub>
Operating Junction Temperature Range		-40 to 150	°C
Storage Temperature Range		-55 to 150	°C
Maximum Soldering Temperature (at leads, 10 sec)		260	°C

## ESD Ratings<sup>2</sup>

Symbol	Description	Value	Units
V (ESD) Electrostatic Discharge	Human body model (HBM), per ANSI/ESDA/JEDEC JS-001, all pins	±2000	V
	Charged device model (CDM), per JEDEC specification JESD22C101, all pins	±500	

## Thermal Capabilities<sup>3</sup>

Symbol	Description	Value	Units
Θ <sub>JA</sub>	Thermal Resistance – Junction to Ambient	67.7	°C/W
P <sub>D</sub>	Maximum Power Dissipation at T <sub>A</sub> = 25°C	1.85	W
ΔPD/ΔT	Derating Factor Above T <sub>A</sub> = 25°C	-14.77	mW/°C

## Ordering Information

Part Number <sup>4</sup>	Marking <sup>5</sup>	Default Settings <sup>6</sup>				Package
		V <sub>OUT</sub>	F <sub>sw</sub>	FCCM or Auto-Skip Mode	Active Discharged	
KTB8370AEIB-5C-TR	OLXXYYZZZZ	5.0V	500kHz	Auto-Skip	Disabled	WLCSP20
KTB8370BEIB-5C-TR	OPXXYYZZZZ	3.3V	500kHz	Auto-Skip	Disabled	WLCSP20
KTB8370CEIB-5C-TR	OTXXYYZZZZ	1.8V	500kHz	Auto-Skip	Disabled	WLCSP20

- Functional operation at conditions other than the operating conditions specified is not implied. Only one Absolute Maximum rating should be applied at any one time.
- ESD Ratings conform to JEDEC industry standards. Some pins may have higher performance. Ratings apply with chip enabled, disabled, or unpowered, unless otherwise noted.
- Junction to Ambient thermal resistance is highly dependent on PCB layout. Values are based on thermal properties of the device when soldered to an EV board.
- For part numbers in italics or alternative default combinations, please contact your local sales representative
- XX = Date Code, YY = Assembly Code, ZZZZ = Serial Number.
- Contact a Kinetic Technologies representative regarding versions with other default settings.

**Electrical Characteristics<sup>7</sup>**

Unless otherwise noted, *Typ* values are specified at +25°C with  $V_{IN} = 12V$ . The *Min* and *Max* specs are applied over the full operation temperature range of -40°C to +85°C and  $V_{IN} = 4.7V$  to 17V.

Symbol	Description	Conditions	Min	Typ	Max	Units
<b>Supply Specifications</b>						
$PV_{IN}$	Input Supply Operating Range		4.7		17	V
$V_{UVLO}$	Under-Voltage Lockout Threshold	$V_{IN}$ rising	3.35	4.25	4.7	V
		Hysteresis		500		mV
$I_{IN}$	$V_{IN}$ Supply Current	EN = High, $V_{IN} = 12V$ , Non-Switching		50		$\mu A$
		EN = High, $V_{IN} = 12V$ , Auto-Skip		80		$\mu A$
		EN = High, $V_{IN} = 12V$ , Forced-PWM		10		mA
$I_{SHDN}$	Shutdown Supply Current	EN = Low, $T_A = 25^\circ C$		0.01	1	$\mu A$
<b>Logic Pin Specifications (EN, PG)</b>						
$V_{IH}$	Input Logic High (EN)		3.8			V
$V_{IL}$	Input Logic Low (EN)				0.4	V
$I_{L\_LK}$	Input Logic Leakage (EN)	$T_A = 25^\circ C$ , $V_{EN} = 5V$		0.01	1	$\mu A$
$V_{OL}$	Output Logic Low (PG)	$I_{O\_SINK} = 100\mu A$			0.4	V
$I_{O\_LK}$	Output Logic Leakage (PG)	$T_A = 25^\circ C$ , $V_O = 5.5V$		1.5	3.8	$\mu A$
<b>Thermal Shutdown Specifications</b>						
$T_{J\_SHDN}$	IC Junction Thermal Shutdown	$T_J$ rising		150		$^\circ C$
		Hysteresis		20		$^\circ C$
<b>Buck Regulator Specifications</b>						
$V_{OUT}$	Output Voltage Setting Range	Factory Programmable Options	0.64		5.5	V
		Output Voltage Step		40		mV
$V_{OUT\_acc}$	Output Voltage DC Accuracy	$T_A = 25^\circ C$ , FCCM	-0.7		0.7	%
$I_{OUT\_max}$	Maximum Continuous Output Current		5			A
$I_{peak}$	High-Side Switch Peak-Current Limiting Threshold		6.4	8	9.6	A
$I_{valley}$	Low-Side Switch Valley-Current Limiting Threshold		6	7.5	9	A
$I_{rev}$	Low-Side Reverse Current Limiting Threshold	FCCM Mode		-3		A
$I_{zcd}$	Zero-Crossing-Detection Threshold	Auto-Skip Mode		0		mA
$R_{dson\_h}$	High-Side Switch On-Resistance			60	75	m $\Omega$
$R_{dson\_l}$	Low-Side Switch On-Resistance			30	40	m $\Omega$
$R_{LX\_DIS}$	LX Active Discharge Resistance	For Active discharge mode enabled option		200		$\Omega$
$K_{AOT}$	Adaptive-On-Time Constant	$t_{ON} = K_{AOT} \times (V_{OUT}/V_{IN})$ , $F_{sw} = 500kHz$ , $V_{OUT} = 5V$		2100		ns
$F_{sw}^8$	Switching Frequency Factory Trim Options	$F_{sw} = 300kHz$		300		kHz
		$F_{sw} = 500kHz$		500		
		$F_{sw} = 800kHz$		800		
		$F_{sw} = 1000kHz$		1000		
$t_{SS\_DELAY}$	$V_{OUT}$ Soft-Start Delay	EN = Low to High		2		ms
$V_{OUT\_RR}$	$V_{OUT}$ Soft-Start Ramp Rate	$V_{OUT} = 5V$		8		mV/ $\mu s$
		$V_{OUT} = 3.3V$		4		
		$V_{OUT} = 1.8V$		3		
$V_{OUT\_PG}$	Output Voltage Power-Good Threshold	Percentage of nominal $V_{OUT}$	85		115	%

7. Device is guaranteed to meet performance specifications over the -40°C to +85°C operating temperature range by design, characterization and correlation with statistical process controls.

8. Switching frequency is factory trimmed options, please refer to ordering information to select relevant part.

## Typical Characteristics

Unless otherwise noted,  $V_{IN} = 12V$ ,  $F_{SW} = 500kHz$ , and  $T_A = 25^\circ C$ .

**Efficiency vs Output Current**  
( $L_1 = 2.2\mu H$ ,  $F_{sw} = 500kHz$ )

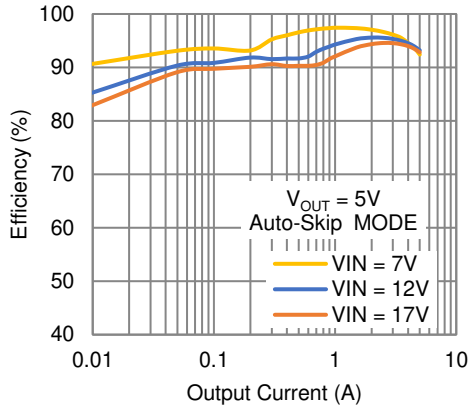

**Efficiency vs Output Current**  
( $L_1 = 2.2\mu H$ ,  $F_{sw} = 500kHz$ )

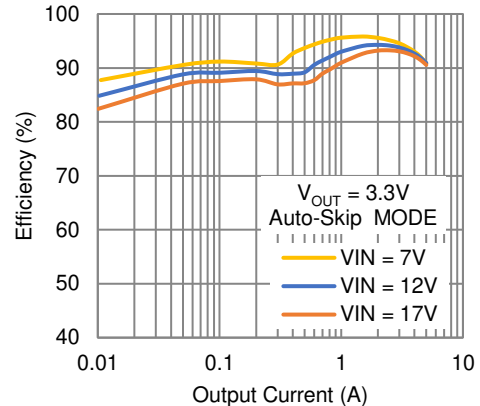

**Efficiency vs Output Current**  
( $L_1 = 2.2\mu H$ ,  $F_{sw} = 500kHz$ )

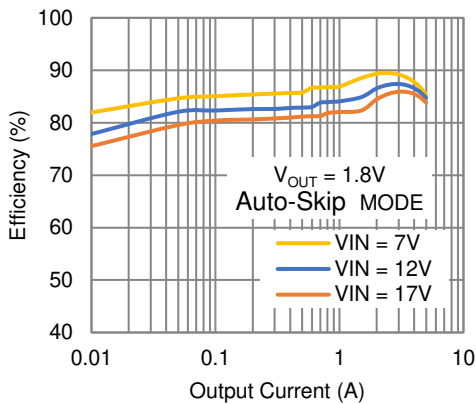

**No Load Input Supply Current vs VIN**

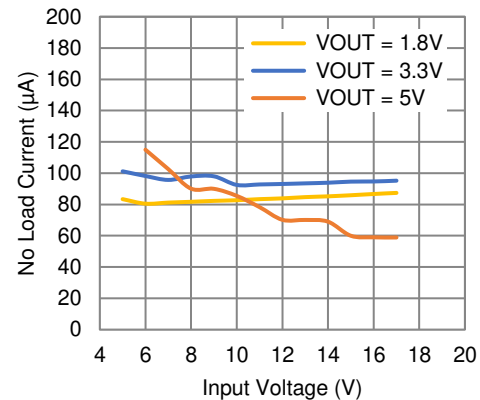

**Switching Frequency vs. Output Current**

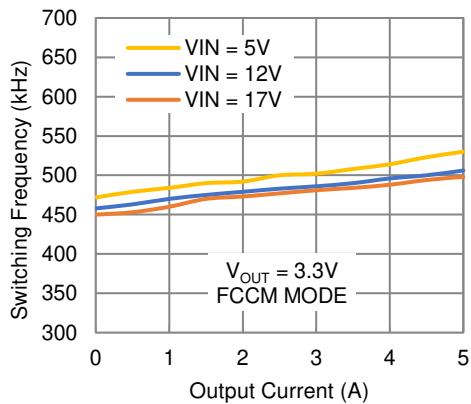

**Line Regulation ( $V_{OUT} = 5V$ , Auto-Skip Mode)**

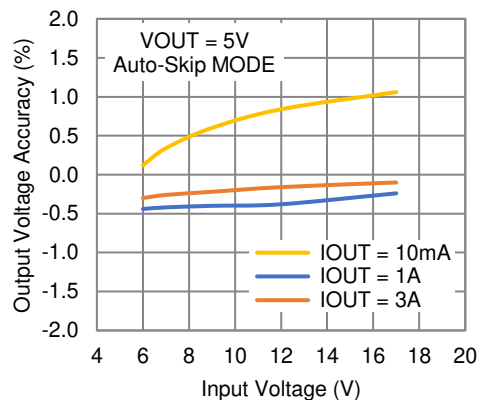

**Typical Characteristics (continued)**

Unless otherwise noted,  $V_{IN} = 12V$ ,  $F_{SW} = 500kHz$ , and  $T_A = 25^\circ C$ .

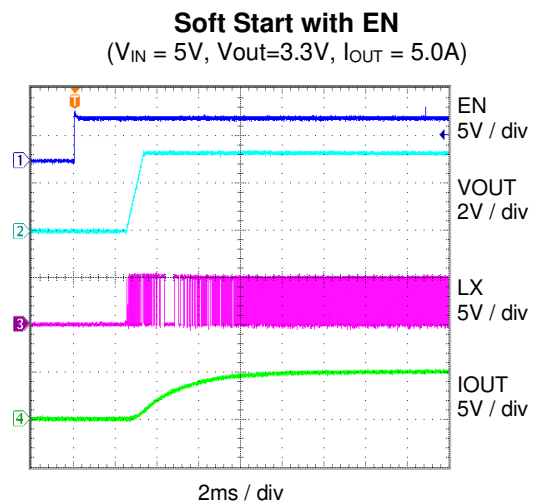
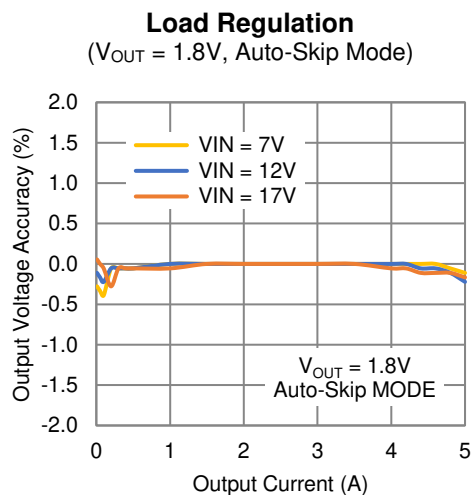
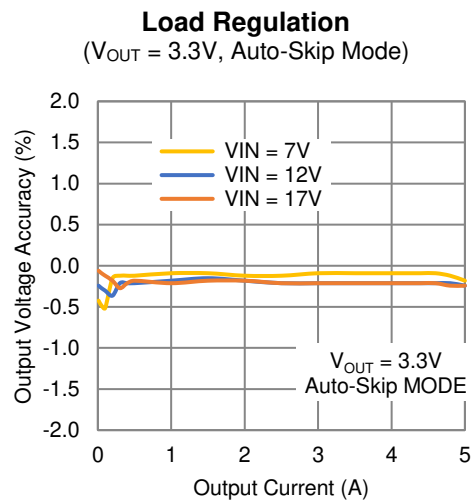
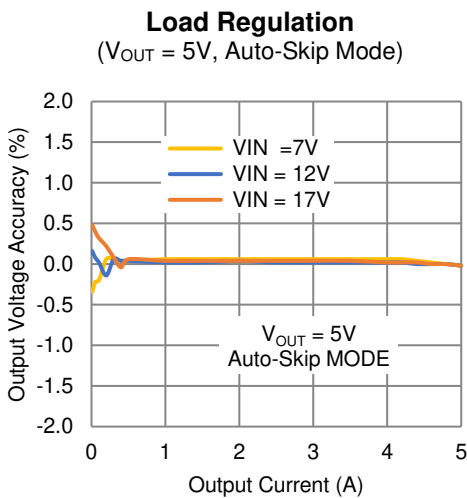
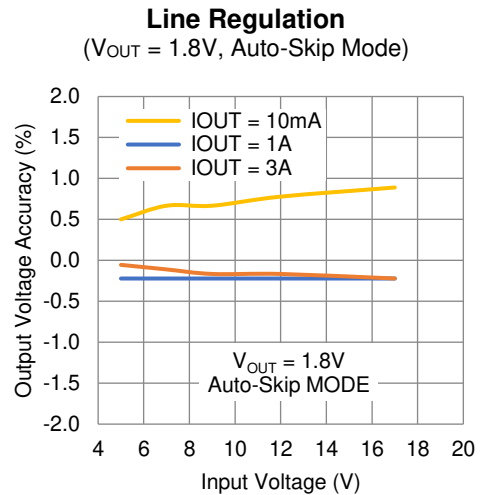
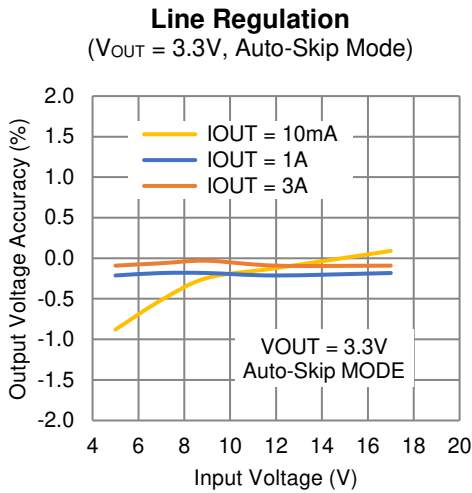

**Typical Characteristics (continued)**

Unless otherwise noted,  $V_{IN} = 12V$ ,  $F_{SW} = 500kHz$ , and  $T_A = 25^\circ C$ .

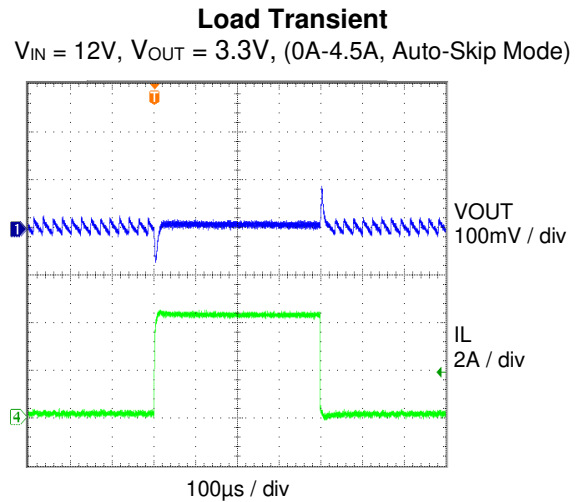
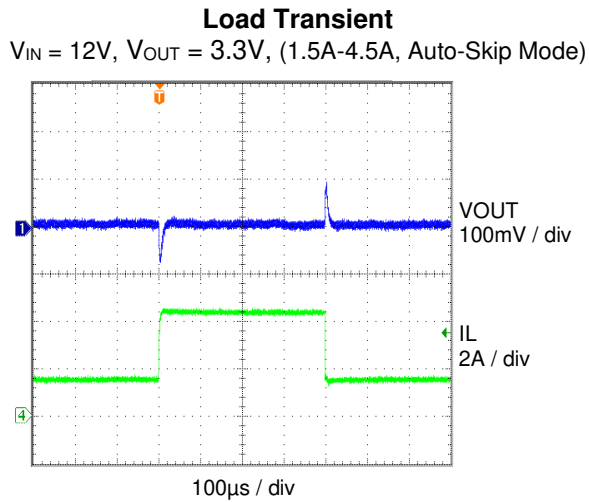
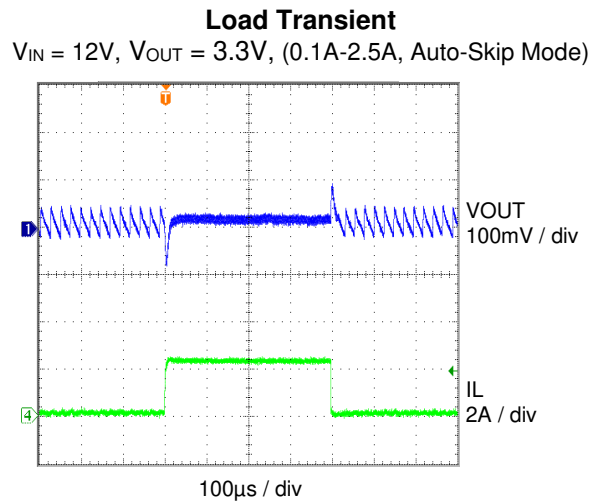
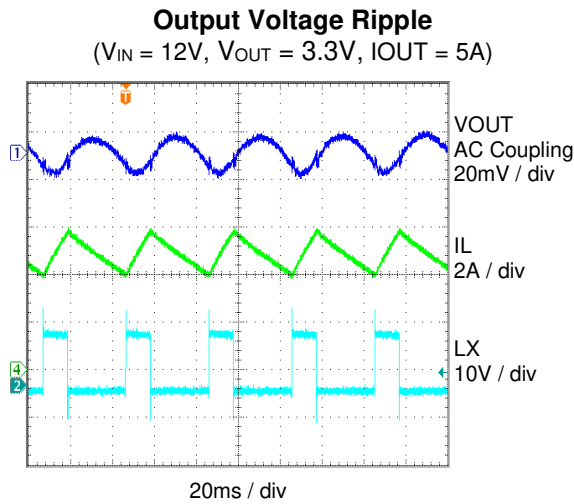
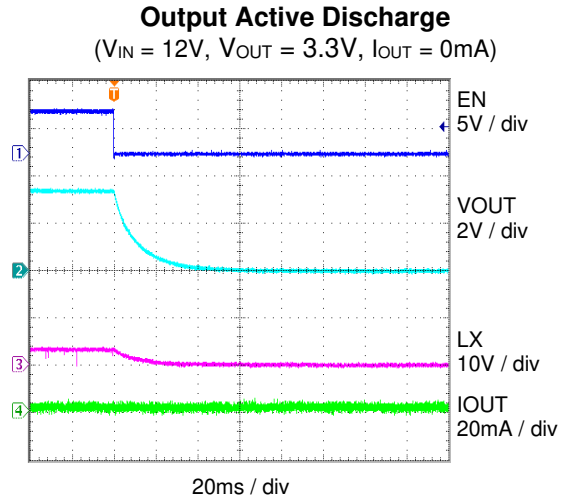
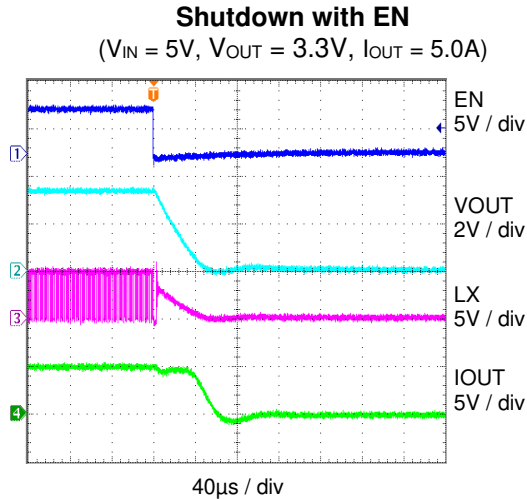

## Typical Characteristics (continued)

Unless otherwise noted,  $V_{IN} = 12V$ ,  $F_{SW} = 500kHz$ , and  $T_A = 25^\circ C$ .

### Output Short Protection Entry

$V_{IN} = 12V$ ,  $V_{OUT} = 3.3V$ , (Hiccup Mode Entry)

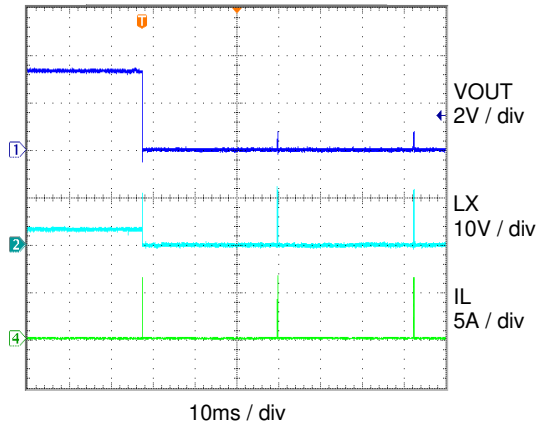

### Output Short Protection Recovery

$V_{IN} = 12V$ ,  $V_{OUT} = 3.3V$ , (Hiccup Mode Recovery)

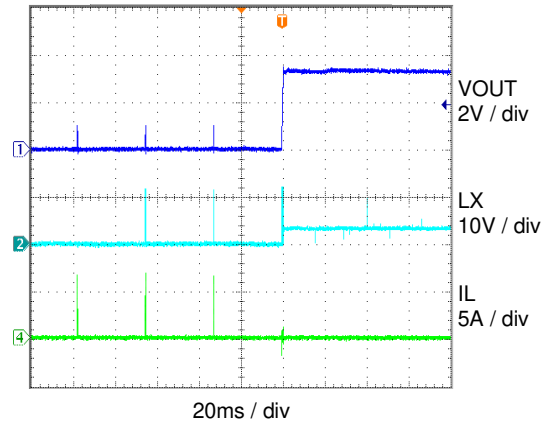



## Functional Description

KTB8370 is a highly efficient, high-performance, monolithic buck regulator that operates from an input voltage of 4.7V to 17V and can output up to 5A. It integrates the main switch, synchronous rectifier switch, PWM control circuitry,  $V_{OUT}$  setting DAC, and various protection features.

### Control Scheme

KTB8370 uses a proprietary adaptive on-time (AOT) PWM control scheme to maintain a nearly constant switching frequency as input voltage and output voltage vary. Compared to typical current-mode PWM schemes, the AOT control scheme provides quick response to line and load transients with excellent stability and wide bandwidth, thereby minimizing output voltage droop and soar for dynamic loads, even with minimal output capacitance. The adaptive on-time approximates fixed-frequency switching without using a fixed clock oscillator, which eliminates the need to wait for the next clock before responding to a load transient.

KTB8370 feedback loop also adds a proprietary, internally compensated, integrating error amplifier to remove the output voltage offset normally associated with other AOT, constant on-time (COT), and hysteretic architectures.

### Shutdown Mode

When the EN pin is low, KTB8370 is in shutdown mode and draws extremely low supply current.

### Enable

KTB8370 buck regulator is turned on and off using the EN pin. Pull EN pin high to enable the buck regulator and pull the EN pin low to disable the buck regulator.

### Soft-Start

KTB8370 contains soft-start circuitry to ramp up  $V_{OUT}$  slowly in order to reduce inrush current at  $V_{IN}$  and prevent the inductor current from reaching the peak current limit during startup. During soft start, the ramp up rate of  $V_{OUT}$  is regulated to a constant value, which can be found in table 1.

**Table 1. Output Voltage Ramp Rate**

Nominal Output Voltage Setting ( $V_{OUT}$ )	$V_{OUT} \leq 2.2V$	$2.2V < V_{OUT} \leq 3.3V$	$3.3V < V_{OUT} \leq 5.5V$
Soft-Start Ramp Rate ( $V_{OUT\_RR}$ )	40mV/ $\mu$ s	60mV/ $\mu$ s	100mV/ $\mu$ s

The soft-start time can be estimated by:  $t_{SS} = V_{OUT} / V_{OUT\_RR}$

### Auto-Skip Mode and Forced-PWM Mode.

KTB8370 has a default automatic skip mode. In the automatic skip mode, KTB8370 transit automatically between constant frequency PWM mode at heavy loads and PFM mode at light loads. Auto-Skip mode is helpful for applications that need high efficiency at light loads. While skipping, single pulses are evenly spaced, resulting in the lowest output ripple and noise when compared to competing “pulse-grouping” or “burst mode” devices.

In applications that are noise sensitive, even at light load conditions, fixed switching frequency is also desired. and the KTB8370 needs to operate in forced PWM mode. A Forced-PWM mode option is available

### Active Discharge Option

KTB8370 features an active discharge option, where a 200 $\Omega$  (typical) on-chip resistor is connected between the LX and PGND pins. This resistor discharges the output capacitor through the inductor when KTB8370 is disabled. KTB8370 can be factory trimmed to Active Discharge. Please contact Kinetic Technologies representative for ordering information.

### Input Under-Voltage Lockout (UVLO)

When the input voltage ( $V_{IN}$ ) is below the under-voltage lockout threshold ( $V_{UVLO}$ ), the buck is disabled. When  $V_{IN}$  rises above  $V_{UVLO}$ , and if the buck is enabled, the default soft-start ramp begins.

### Over-Current Protection (OCP)

KTB8370 features high-side switch peak-current limit and low-side switch valley-current limit, which protect the integrated FETs and inductor during over-current faults. The current limits control the buck’s switching on a cycle-by-cycle basis and have a higher priority than the regulation threshold and adaptive on-time. When either high-side or

low-side FET current reaches their respective over-current limiting threshold, high-side FET is turned off and will be kept off for at least 50ns, while low-side FET is turned on. The high-side FET can only be turned back on until the low-side FET current drops below the valley current limit. During sustained over-current faults, the output voltage typically droops below the regulation threshold.

## Output Short-Circuit Protection

During an over-current event, when 8 consecutive (interval time minimum than 2μs typical) OCP events are detected, KTB8370 will enter hiccup mode and pause all switching. The buck regulator attempts to soft-start after 20ms, if the fault persists, the buck regulator once again enters hiccup mode and periodically re-attempts soft-start until the fault is removed. The low duty-factor during hiccup mode prevents the IC from getting hot.

## Thermal Shutdown

KTB8370 is turned off by an internal thermal shutdown when the junction temperature exceeds the thermal shutdown threshold (150°C typical). The device restarts when the junction temperature drops by 20°C.

## Trim Options

KTB8370 are factory trimmed using one-time programmable (OTP) registers. Standard versions are available for various default output voltage settings and modes – see the *Ordering Information* section. Contact Kinetic Technologies local representative for availability of versions with alternative default settings.

## Applications Information

### Recommended Inductors

The selection of the inductor affects the steady-state operation as well as transient behavior and loop stability. The three most important inductor specifications to consider are inductor value, DC resistance (DCR), and saturation current rating. Higher inductance gives lower inductor current ripple, while lower inductance usually gives faster load transient response. KTB8370 is trimmed for inductors with nominal inductance of 0.8μH to 6.5μH. Select an inductor with a saturation current rating that is higher than KTB8370 peak current limit. Also, choose an inductor with sufficient temperature-rise current rating to satisfy the RMS load-current of the application. Consider the inductor's resistance, since these will affect the efficiency. Larger physical case-sizes, good winding designs, and better magnetic materials can increase efficiency.

### Recommended Capacitors

Ceramic input and output capacitors with X5R or X6S or X7R are recommended due to their low ESR, low ESL, low temperature coefficients, and small physical sizes. Consider the voltage rating, size, and DC bias derating characteristic of the capacitor

#### Input Capacitor

Choose an input capacitor with voltage rating of 25V or more, 10μF nominal capacitance or more, and 0805 case-size or larger. Larger values and larger case-size provide more effective capacitance when considering the DC bias derating characteristic of the capacitor. If the application's input voltage is supplied through a connector or a cable, add additional bypass capacitance where  $V_{IN}$  first arrives to the PCB.

#### Output Capacitors

Choose output capacitors with voltage rating of 10V or more, 22μF total nominal capacitance or more, and 0805 case-size or larger. Consider the  $V_{OUT}$  setting of the regulator and how case size has a significant impact on DC bias derating. At high  $V_{OUT}$  settings, more total nominal capacitance is needed to achieve the same effective capacitance compared to lower  $V_{OUT}$  settings.

For the very best possible load transient response, use multiple capacitors in parallel to achieve sufficient total effective output capacitance:

$$C_{OUTEFFECTIVE} \geq \frac{L \times I_{STEP}}{33m\Omega \times (V_{IN} - V_{OUT})}$$

where  $I_{STEP}$  is the largest load transient step in the application, and 33mΩ is constant set by internal control circuit. Please note that the above formula is already guard-banded by a margin of 2x to accommodate capacitor and inductor tolerances and the variability of a transient arrival time with respect to the switching cycle of the regulator.

If needed, the total effective output capacitance can be distributed by placing additional capacitors remotely at the point of load. In applications where transient performance is less critical, especially when  $V_{IN}$  minus  $V_{OUT}$  is small, it is acceptable to reduce the total effective output capacitance to save board space and cost at the expense of load transient droop and soar.

As a design example, consider a system with  $V_{IN} = 12V$  (min),  $V_{OUT} = 1.8V$ , and  $I_{STEP} = 5A$  (max):

$$C_{OUT_{EFFECTIVE}} \geq \frac{1\mu H \times 5A}{33m\Omega \times (12V - 1.8V)} \cong 15\mu F$$

In this example, choose output capacitors with total effective capacitance of  $14\mu F$  or more at a DC bias of  $1.8V$ . A single  $15\mu F$  capacitor will not be enough when considering its DC bias characteristic, per Figure 1. At  $1.8V$  bias, it retains only about  $8\mu F$ ; therefore, for best transient response, use two of these capacitors in parallel for a total effective capacitance of  $16\mu F$ .

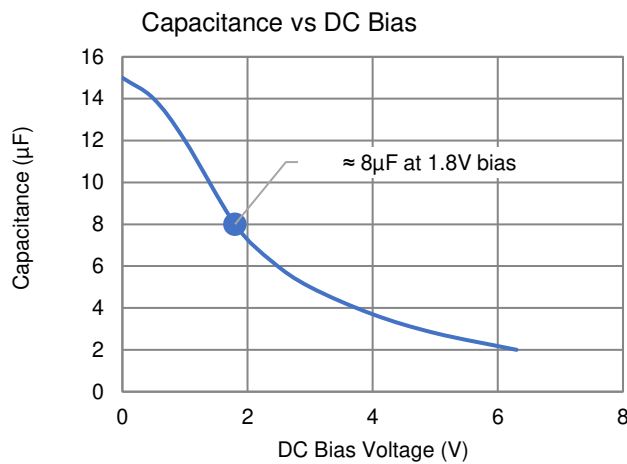

**Figure 1. Typical DC Bias Derating Characteristic an Example  $15\mu F$  Ceramic Capacitor.**

## Recommended PCB Layout

Refer to U1 = KTB8370; C2 - C4 = C<sub>IN</sub>; C5-C6 = C<sub>OUT</sub>; C8 = C<sub>BST</sub>

Figure 2 for example, PCB layouts optimized for small footprint, low EMI, and good performance. The example follows the below PCB layout recommendations:

1. Connect the input capacitor C<sub>IN</sub> as close as possible to the VIN and PGND pins using top-side thick metal traces.
2. Connect the ground terminals of output capacitors C<sub>OUT</sub> as close as possible to the ground terminal of C<sub>IN</sub> and the PGND pins using top-side metal.
3. Connect the Boost capacitor as close as possible to the Boost pin and Lx pin of the chip.
4. Connect the local top side PGND island to the PCB ground plane using multiple parallel vias.
5. Do not connect the AGND pins directly to the top side PGND. Instead, connect the AGND pins to the PCB ground plane using their own vias.
6. Connect the inductor to the LX pins with a wide trace.
7. Connect the V<sub>OUT</sub> terminals of the inductor to the output capacitors with a wide and short trace.
8. Route the V<sub>OUT</sub> sense trace from C<sub>OUT</sub> to the V<sub>OUT</sub> pin with care to keep it away from noisy traces, especially the LX trace. Additionally, use ground fill to shield noise from coupling into the V<sub>OUT</sub> sense.
9. Depending upon PCB design rules, it may be possible to place filled micro-vias directly under WLCSP bumps. If not, route short traces to nearby vias.

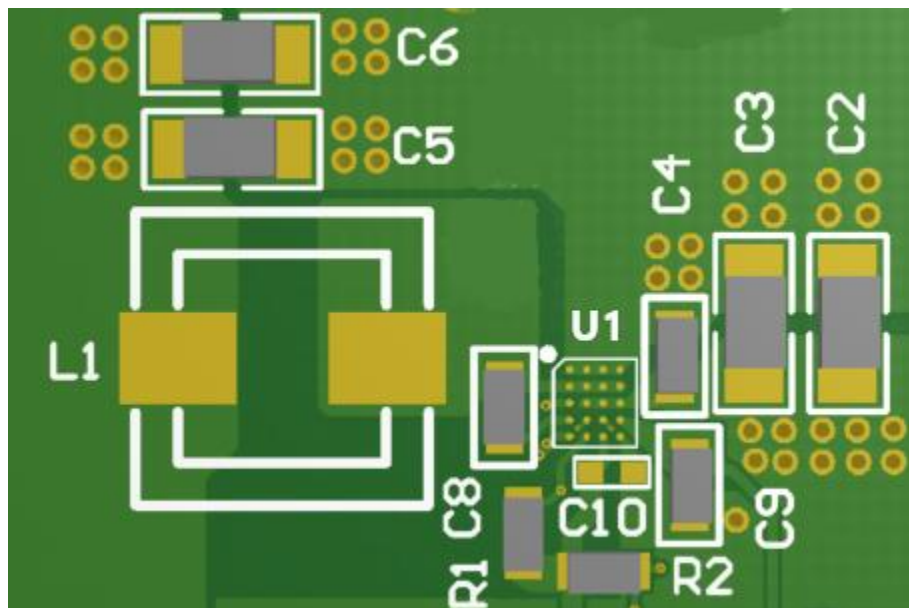

U1 = KTB8370; C2 - C4 = C<sub>IN</sub>; C5-C6 = C<sub>OUT</sub>; C8 = C<sub>BST</sub>

Figure 2. Recommended PCB Layouts

**Packaging Information**

WLCSP45-20 (1.750mm x 2.063mm x 0.62mm)

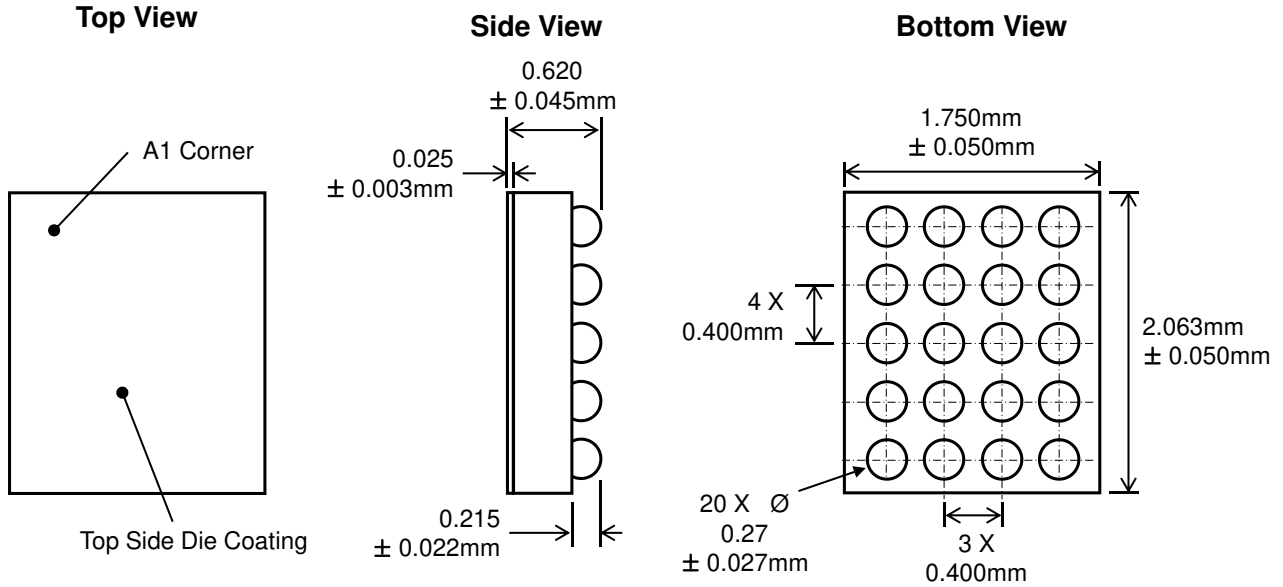

**Recommended Footprint**

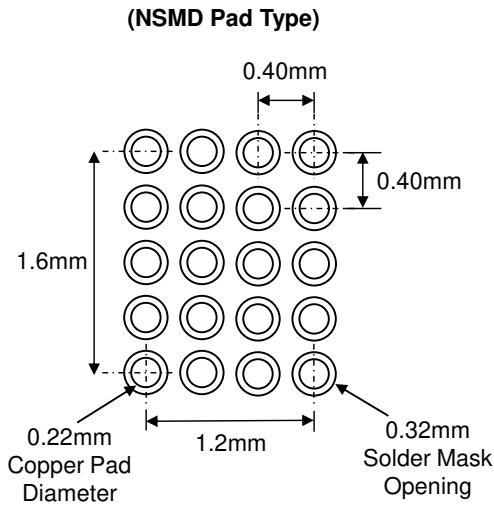

\* Dimensions are in millimeters.

Kinetic Technologies cannot assume responsibility for use of any circuitry other than circuitry entirely embodied in a Kinetic Technologies product. No intellectual property or circuit patent licenses are implied. Kinetic Technologies reserves the right to change the circuitry and specifications without notice at any time.