

DESCRIPTION

The LX1882 is a two-stage boost regulator featuring a charge pump doubler with an integrated low dropout linear regulator.

The first stage features an internal doubler charge pump converting an input supply of 1.8V to 4.4V, while the second stage is an LDO regulating the boosted voltage converting it to a regulated output.

The LX1882 is capable of supplying up to 50mA of output current with an

operating current of less than 150 μ A. Quiescent current is reduced to < 5 μ A in shutdown mode.

The LX1882's internal regulator is stable with either Tantalum or Ceramic low-value capacitors, typically 2.2 μ F on the output, allowing designers flexibility in external component selection.

Reliability and safety features include Thermal Shutdown Protection and Integrated Short-Circuit Protection.

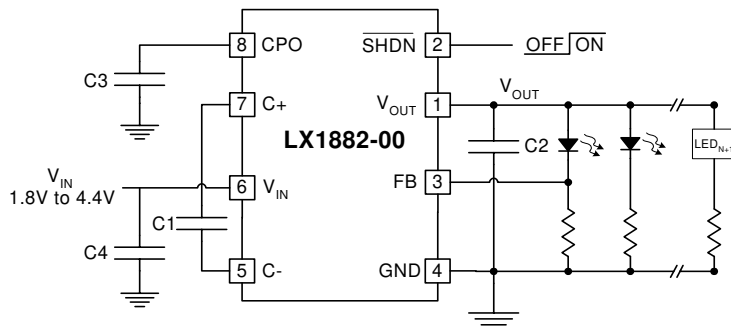
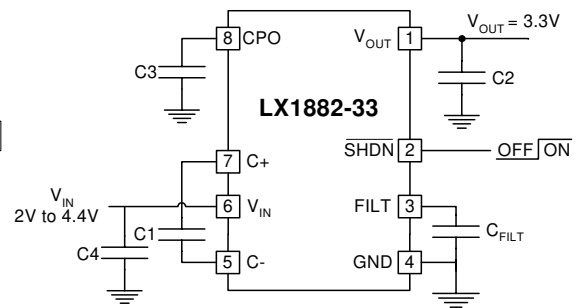
KEY FEATURES

- Wide Input Voltage: 1.8V to 4.4V
- 3.3V and Adjustable (2.5V to 5.5V) Output Voltage Options
- Inductor-less design using small ceramic capacitors
- Low Shutdown Current of 1 μ A
- Internal Thermal Shutdown and Current Limiting
- 550kHz Switching Operation

APPLICATIONS/BENEFITS

- Cellular Telephone VCO Supplies
- Medical Instrumentation
- Data Acquisition
- Wireless PCMCIA Applications
- EMI Sensitive Boost Applications

IMPORTANT: For the most current data, consult MICROSEMI's website: <http://www.microsemi.com>

PRODUCT HIGHLIGHT

LX1882: Adjustable Output; LED Driver

LX1882: Fixed 3.3V Output
PACKAGE ORDER INFO

T _J (°C)	INPUT	OUTPUT	DM	Plastic SOIC 8-PIN	DU	Plastic MSOP 8-PIN
			RoHS Compliant / Pb-free Transition DC: 0440		RoHS Compliant / Pb-free Transition DC: 0432	
0 to 70	1.8V – 4.4V	Adj	LX1882-00CDM		LX1882-00CDU	
	2V – 4.4V	3.3V	LX1882-33CDM		LX1882-33CDU	

Note: Available in Tape & Reel. Append the letters "TR" to the part number. (i.e. LX1882-00CDU-TR)

ABSOLUTE MAXIMUM RATINGS

V_{IN} to GND	-0.3V to 5V
V_{OUT} Voltage.....	-0.3V to 6V
CPO to Ground.....	10V
\overline{SHDN} , FILT, FB Voltage to Ground.....	-0.3V to ($V_{IN} + 0.3V$)
V_{OUT} Short-Circuit Duration.....	Indefinite
I_{OUT}	90mA
Operating Temperature Range	
Commercial	0°C to 70°C
Storage Temperature	-65°C to 150°C
Maximum Junction Temperature	125°C
Pb-free / RoHS Peak package Solder Reflow Temp. (40 second max. exposure).....	260°C (+0, -5)

Note: Exceeding these ratings could cause damage to the device. All voltages are with respect to Ground. Currents are positive into, negative out of specified terminal.

THERMAL DATA
DM Plastic 8-Pin SOIC

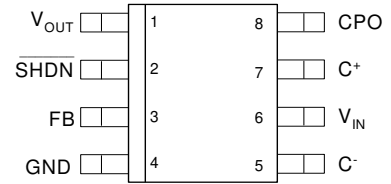
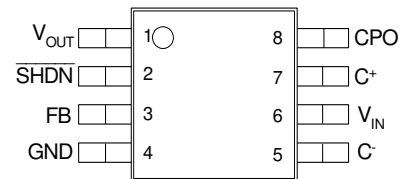
THERMAL RESISTANCE-JUNCTION TO AMBIENT, θ_{JA}	163°C/W
THERMAL RESISTANCE-JUNCTION TO CASE, θ_{JC}	38°C/W

DU Plastic 8-Pin MSOP

THERMAL RESISTANCE-JUNCTION TO AMBIENT, θ_{JA}	206°C/W
THERMAL RESISTANCE-JUNCTION TO CASE, θ_{JC}	39°C/W

Junction Temperature Calculation: $T_J = T_A + (P_D \times \theta_{JA})$.

The θ_{JA} numbers are guidelines for the thermal performance of the device/pc-board system. All of the above assume no ambient airflow.

PACKAGE PIN OUT

DM PACKAGE
(Top View)

DU PACKAGE
(Top View)

RoHS / Pb-free 100% Matte Tin Lead Finish

FUNCTIONAL PIN DESCRIPTION

PIN NAME	PIN #	DESCRIPTION
V_{OUT}	1	Regulated Output Voltage. It is recommended to bypass V_{OUT} with a low ESR capacitor ($> 2\mu F$) placed as close to the pin as possible for best performance. For the adjustable version, the output voltage range is 2.5V to 5.5V.
\overline{SHDN}	2	Shutdown Pin. The LX1882 is in shutdown mode when a logic low is applied to this pin. Inversely, a logic high applied to this pin enables the device. When in shutdown mode, the charge pump output is disconnected from V_{IN} (CPO will be high impedance) and V_{OUT} is connected to ground through an internal 100 Ω switch.
FB	3	Adjustable Version Only. The output voltage can be set by two resistors with the following relationship: $V_{OUT} = FB * (1 + (R_1/R_2))$ where R_1 is the resistor connected between V_{OUT} and FB, and R_2 is the resistor connected between FB and GND (see figure 3 on page 6).
FILT	3	Fixed Version Only. Filter pin for internal voltage reference. Typically a 1nF capacitor is connected from FILT to GND.
GND	4	System Ground.
C^-	5	Flying Capacitor Negative Input.
V_{IN}	6	Input Voltage. The input voltage range is 1.8V to 4.4V for the LX1882-00 and 2V to 4.4V for the LX1882-33. V_{IN} should be bypassed with a $> 2\mu F$ low ESR capacitor placed as close to the pin as possible for best performance. A minimum capacitance value of 0.1 μF is required.
C^+	7	Flying Capacitor Positive Input.
CPO	8	Charge Pump Output Voltage. CPO is approximately 1.95(V_{IN}) at low loads. CPO should be bypassed with a low ESR capacitor ($> 2\mu F$).

SIMPLIFIED BLOCK DIAGRAM

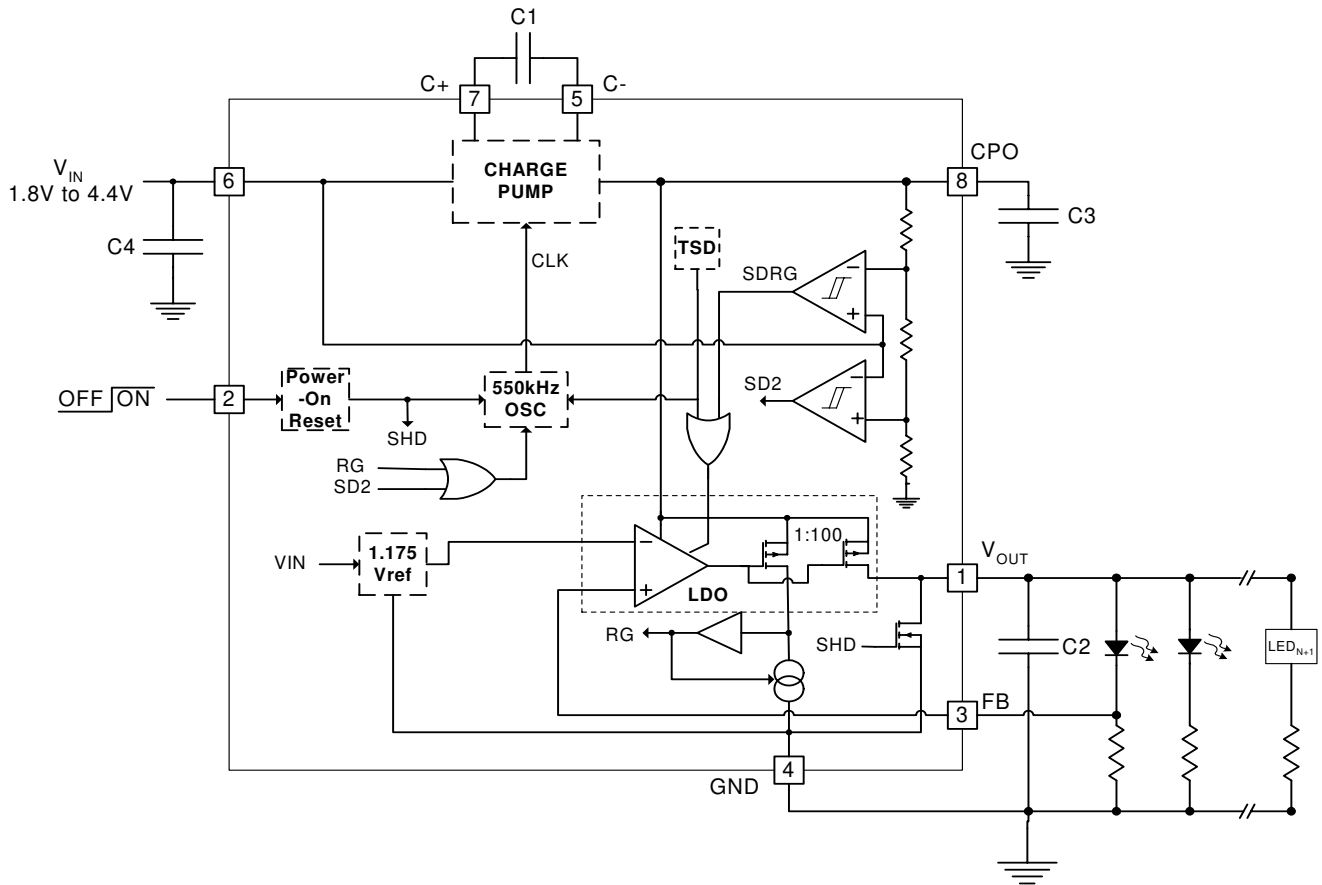


Figure 1 – LX1882-00 Block Diagram

SIMPLIFIED BLOCK DIAGRAM

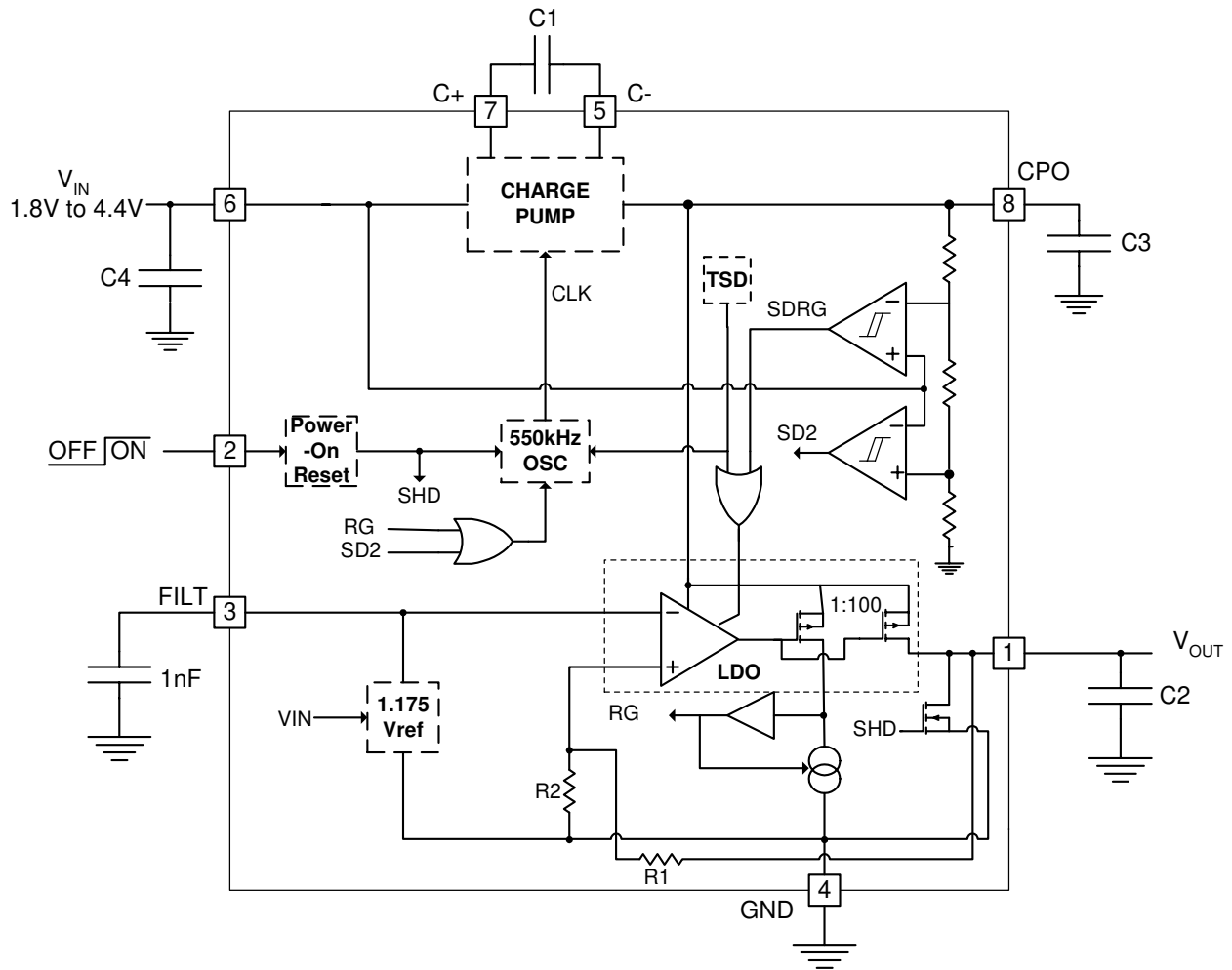


Figure 2 – LX1882-33 Block Diagram

ELECTRICAL CHARACTERISTICS

Unless otherwise specified, the following specifications apply over the operating ambient temperature $0^{\circ}\text{C} \leq T_A \leq 70^{\circ}\text{C}$ except where otherwise noted. Test conditions: $\overline{\text{SHDN}} = V_{\text{IN}} = 3\text{V}$, $C_1 = 0.22\mu\text{F}$, $C_2 = C_3 = C_4 = 4.7\mu\text{F}$

Parameter	Symbol	Test Conditions	LX1882-xx			Units
			Min	Typ	Max	
Operating Voltage	V_{IN}	LX1882-00 LX1882-33	1.8 2.0		4.4 4.4	V
I_{VIN} Shutdown Current		$\overline{\text{SHDN}} = 0\text{V}$		1	5	μA
I_{VIN} Operating Current		$I_{\text{OUT}} = 0\text{mA}$, Burst Mode Operation		250	400	μA
FB Input Current		FB=1.175V	-50		50	nA
FB Voltage	V_{FB}	LX1882-00 only; $I_{\text{OUT}} = 1\text{mA}$	1.15	1.175	1.20	V
Regulated Output Voltage	V_{OUT}	LX1882-33; $I_{\text{OUT}} = 1\text{mA}$	3.23	3.30	3.37	V
V_{OUT} Temperature Coefficient		$T_A = 25^{\circ}\text{C}$		± 150		ppm
Charge Pump Oscillator Frequency	F_{OSC}	$I_{\text{OUT}} > 200\mu\text{A}$, $V_{\text{IN}} = 1.8\text{V}$ to 4.4V	480	550	620	kHz
CPO (Charge Pump Output) Output Resistance	R_{CPO}	$V_{\text{IN}} = 1.8\text{V}$, $I_{\text{OUT}} = 10\text{mA}$		22	30	Ω
		$V_{\text{IN}} = 3\text{V}$, $I_{\text{OUT}} = 10\text{mA}$		16	20	Ω
		$V_{\text{IN}} = 4.4\text{V}$, $I_{\text{OUT}} = 10\text{mA}$		10	20	Ω
V_{OUT} Dropout Voltage (Note 1)	ΔV	LX1882-00; $I_{\text{OUT}} = 10\text{mA}$, $V_{\text{OUT}} = 2.7\text{V}$ LX1882-33; $I_{\text{OUT}} = 10\text{mA}$, $V_{\text{OUT}} = 3.3\text{V}$		100 75	160 120	mV
V_{OUT} Enable Time		$I_{\text{OUT}} = 10\text{mA}$, $T_A = 25^{\circ}\text{C}$		350		μs
V_{OUT} Line Regulation	$\Delta V_{\text{OUT}}(V_{\text{IN}})$	$V_{\text{IN}} = 3\text{V}$ to 4V , $I_{\text{OUT}} = 0\text{mA}$		17	30	mV
V_{OUT} Load Regulation	$\Delta V_{\text{OUT}}(I_{\text{OUT}})$	$I_{\text{OUT}} = 1\text{mA}$ to 10mA		3	10	mV
		$I_{\text{OUT}} = 1\text{mA}$ to 50mA		40		mV
V_{OUT} Shutdown Resistance		$\overline{\text{SHDN}} = 0\text{V}$, Resistance Measured to GND, $V_{\text{IN}} = 1.8\text{V}$		120	350	Ω
		$\overline{\text{SHDN}} = 0\text{V}$, Resistance Measured to GND, $V_{\text{IN}} = 4.4\text{V}$		50	150	Ω
$\overline{\text{SHDN}}$ Input Threshold		$V_{\text{IN}} = 1.8\text{V}$ to 4.4V	0.4	1	1.6	V
$\overline{\text{SHDN}}$ Input Current		$\overline{\text{SHDN}} = V_{\text{IN}}$	-1		1	μA
		$\overline{\text{SHDN}} = 0\text{V}$	-1		1	μA

Note 1: Dropout voltage is defined as the minimum input to output differential required to maintain regulation.

APPLICATION INFORMATION
OPERATION

Using a switched-capacitor charge pump, the LX1882 generates a charge pump output (CPO) voltage approximately twice the input voltage. The charge pump is a doubler configuration using one external flying capacitor. A 2-phase non-overlapping clock, generated from an internally trimmed oscillator, controls the charge pump switches to ensure maximum efficiency. CPO powers an internal low dropout (LDO) linear regulator providing a regulated output at V_{OUT} . CPO can also be used to drive an external load; refer to section on CPO Loading. The CPO voltage and V_{IN} are sensed via internal comparators for power-up conditioning. At power-up, the LDO is disabled and the load is removed from CPO. The LDO is enabled when the CPO voltage reaches $1.75(V_{IN})$. When the CPO voltage drops below $1.45(V_{IN})$, the LDO is disabled. Sensing the LX1882 output current determines the charge pump operating mode. If the output current is less than 100 μ A and the CPO voltage is greater than $1.95(V_{IN})$, the charge pump operates in Burst Mode. In Burst Mode, the clock is disabled for increased efficiency, until the CPO voltage droops approximately 100mV at which time the clock is enabled. To minimize noise at CPO, a low ESR capacitor of at least 2 μ F should be used.

The internal LDO can supply up to 50mA of output current and requires an output capacitor between V_{OUT} and GND to stabilize the internal control loop. A low ESR capacitor of at least 2 μ F is recommended.

ADJUSTABLE OUTPUT VOLTAGE

The LX1882-00 develops a 1.175 reference voltage between the FB pin and GND. The output voltage can be set using an external resistor divider (see Figure 3).

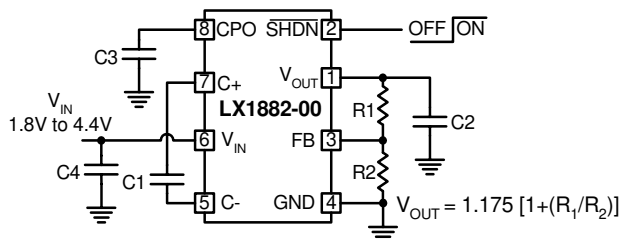


Figure 3. LX1882-00; Adjustable Version

The output voltage range is 2.5V to 5.5V.

MAXIMUM V_{OUT} AND I_{OUT} CALCULATIONS

Using the open circuit CPO voltage ($\approx 2(V_{IN})$), the dropout voltage of the LDO, and the effective charge pump output resistance, the maximum available output voltage and current can be calculated.

MAXIMUM V_{OUT} AND I_{OUT} CALCULATIONS (CONT'D)

The maximum available output voltage can be calculated given a minimum input voltage and output current load using the following equation:

$$V_{OUT(max)} = 2(V_{IN(min)} - (I_{OUT})(R_{CPO}) - V_{DROPOUT}$$

with the condition that $(I_{OUT})(R_{CPO}) < 0.55V_{IN}$.

Example:

$$V_{IN(max)} = 3V$$

$$I_{OUT} = 10mA$$

$$R_{CPO(max)} = 20\Omega$$

$$\text{Unloaded CPO Voltage (max)} = 6V$$

$$\text{Loaded CPO Voltage} = 6V - (10mA)(20\Omega) = 5.8V$$

$$V_{DROPOUT} = 0.075V$$

$$V_{OUT(max)} = (6V) - (0.2) - (0.075) = 5.73$$

$$V_{OUT} < 5.5 \text{ and } (I_{OUT})(R_{CPO}) < 0.55V_{IN}, 0.2V < 1.65V$$

For minimum noise applications, keep the LDO out of dropout to prevent CPO noise from coupling into V_{OUT} .

CAPACITOR SELECTION

To reduce noise and ripple, it is recommended to use low ESR capacitors for C2 (V_{OUT}), C3 (CPO), and C4 (V_{IN}); see Figure 1. For stability purposes, C2 must be at least 2 μ F and C3 must be equal to or greater than C2. It is also recommended that C4 be at least 2 μ F. A 2.2 Ω resistor may be required between V_{IN} and the supply to reduce ripple that may be induced onto the voltage rail due to large instantaneous currents demanded by the charge pump.

A 0.22 μ F, low ESR ceramic capacitor is recommended for C1 (charge pump flying capacitor). To improve V_{OUT} ripple for light loads or for high V_{IN} , a smaller capacitor could be used for C1 to reduce ripple on CPO.

To minimize the enable time, the CPO filter capacitor (C3) should be at least 2x the V_{OUT} filter capacitor (C2). At power-up, the LDO is disabled and the load is removed from CPO. When the CPO voltage reaches $1.75(V_{IN})$ the LDO is enabled and a large amount of charge is dumped from the CPO capacitor into the V_{OUT} capacitor. If the amount of charge dumped causes the CPO voltage to fall below $1.45(V_{IN})$, the LDO will be disabled and the CPO voltage will have to charge up to $1.75(V_{IN})$ to enable the LDO. This cycle results in an extended enable time.

For the LX1882-33, a 1nF filter capacitor should be connected between the FILT pin and GND for optimum noise performance.

CPO LOADING

The CPO can drive an external load. Current draw by the external load will reduce the maximum available current at V_{OUT} (i.e. if CPO is driving a 5mA load, the available current from V_{OUT} will be reduced by 5mA).

APPLICATION INFORMATION (CONTINUED)

POWER-ON RESET

The LX1882 contains power-on reset circuitry that insures all internal functions are correctly initialized upon power-up. Once the input voltage reaches approximately 1V, the power-on reset circuit enables the device as long as the $\overline{\text{SHDN}}$ pin is held high.

SHUTDOWN

The $\overline{\text{SHDN}}$ pin allows the LX1882 to be enabled or disabled. A logic zero (0.4V) on the $\overline{\text{SHDN}}$ pin places the LX1882 in shutdown mode, reducing the supply current to $< 5\mu\text{A}$ and connecting V_{OUT} to ground through a 100Ω switch. In addition, CPO will be high impedance and disconnected from V_{IN} . If the shutdown feature is not required, connect $\overline{\text{SHDN}}$ to V_{IN} to continuously enable the part.

Current Limit Protection

The LX1882 includes over current protection. When the output load current exceeds typically 60mA, the circuit forces the regulator output to decrease.

Temperature Protection

The thermal protection shuts the LX1882 down when the junction temperature exceeds 140°C . Exposure to absolute maximum rated conditions for extended periods may affect device reliability (see Thermal Considerations below).

THERMAL CONSIDERATIONS

Thermal shutdown protects the circuit from thermal overload caused from a rise in junction temperature during power dissipation. This means of protection is intended for fault protection only and not as a means from current or power limiting during normal application usage. Proper thermal evaluation should be done to ensure that the junction temperature does not exceed its maximum rating (125°C). Due to variation in individual device electrical characteristics and thermal resistance, the built in thermal overload protection may be activated at power levels slightly above or below the rated dissipation.

EVALUATION BOARD

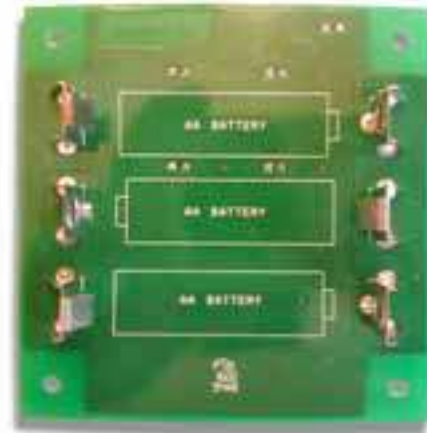
Figure 4. LX1882 LED Driver Evaluation Board (Top View)

Figure 5. LX1882 LED Driver Evaluation Board (Bottom View)

Table 1: Input and Output Pin Assignments

Pin Name	Description
VIN	Input Voltage Test Point. Use this pin to monitor the input voltage.
VOUT	Output Voltage Test Point. Use this pin to monitor output voltage. Output Voltage is determined using the following equation: $V_{OUT} = V_{FB} [1 + (R_1/R_2)] - V_{SET} (R_1/R_2)$; where $V_{SET} = I_{LED} (R_3)$ and $V_{FB} = 1.175V$ (see Figure 6).
FB	Feedback Pin Test Point. Use this pin to monitor feedback voltage. Min = 1.150V, Typical = 1.175V, Max = 1.20V.
CPO	Charge Pump Output Test Point. Use this pin to monitor the charge pump output or connect an external load to this pin for the charge pump to drive. Note: Maximum output current available is reduced by the amount of current drawn from the CPO pin.
$\overline{\text{SHDN}}$	Shutdown Test Point. Use this pin to monitor operating status of device. Logic HIGH = enabled; Logic LOW = shutdown mode (see Table 2 below).
GND	System Ground Test Points.
External VCC	External DC Input Voltage. Apply a 1.8V to 4.4V input to this pin when switch "VCC" is set to "EXT". Clip the positive lead of the external power supply to the pin of the 2-pin header labeled "External VCC +". Clip the negative lead of the external power supply to the pin of the 2-pin header labeled "External VCC -".

Table 2: Switch Position Assignments

Switch Name	Functional Description
VCC EXT	Use this position when powering the board from an external power supply.
VCC BAT	Use this position when powering the board using "AA" batteries. Three "AA" batteries can be installed via battery clips located on the back of the board.
$\overline{\text{SHDN}}$ ENABLE	Use this position to enable the LX1882.
$\overline{\text{SHDN}}$ DISABLE	Use this position to disable the LX1882.

EVALUATION BOARD (CONTINUED)

Table 3: Factory Installed Component List for the LX1882 Evaluation Board

Quantity	Part Reference	Description	Manufacturer	Part Number
1	C1	Capacitor, Ceramic, 0.22uF, 16V, 10%, 0805 Type SMT	Panasonic	ECJ2VB1C224K
3	C2 - C4	Capacitor, Ceramic X5R, 4.7uF, 25V, 1210 Type SMT	Taiyo Yuden	CETMK325BJ475MN
4	D1 - 4	White LED	Chicago Miniature	CMD333UWC
3	J1 – J3	Terminal Battery Clip, Positive Button, AA Contacts	Keystone	596
3	J4 – J6	Terminal Battery Clip, Negative Button, AA Contacts	Keystone	590
1	P2	Header, 2-Pin	Molex	42375-2
1	R1	Resistor, 46.4K, 1/10W,1%, 0805 Type SMT	Panasonic	ERJ6EKF4642
1	R2	Resistor, 14.3K, 1/10W,1%, 0805 Type SMT	Panasonic	ERJ6EKF1432
4	R3 - R6	Resistor, 30.1, 1/10W,1%, 0805 Type SMT	Panasonic	ERJ6EKF30R1
1	R8	Resistor, 10.0K, 1/10W,1%, 0805 Type SMT	Panasonic	ERJ6EKF1002
2	S1, S2	Switch, SPDT, 1 position, SMT DIP Type	CTS	204-121ST
9	TP1 – TP9	Terminal, Surface Mount, Compact Style Test Point	Keystone	5016
1	U1	IC, LX1882 Charge Pump Doubler with Linear Regulator	Microsemi	LX1882-00CDM

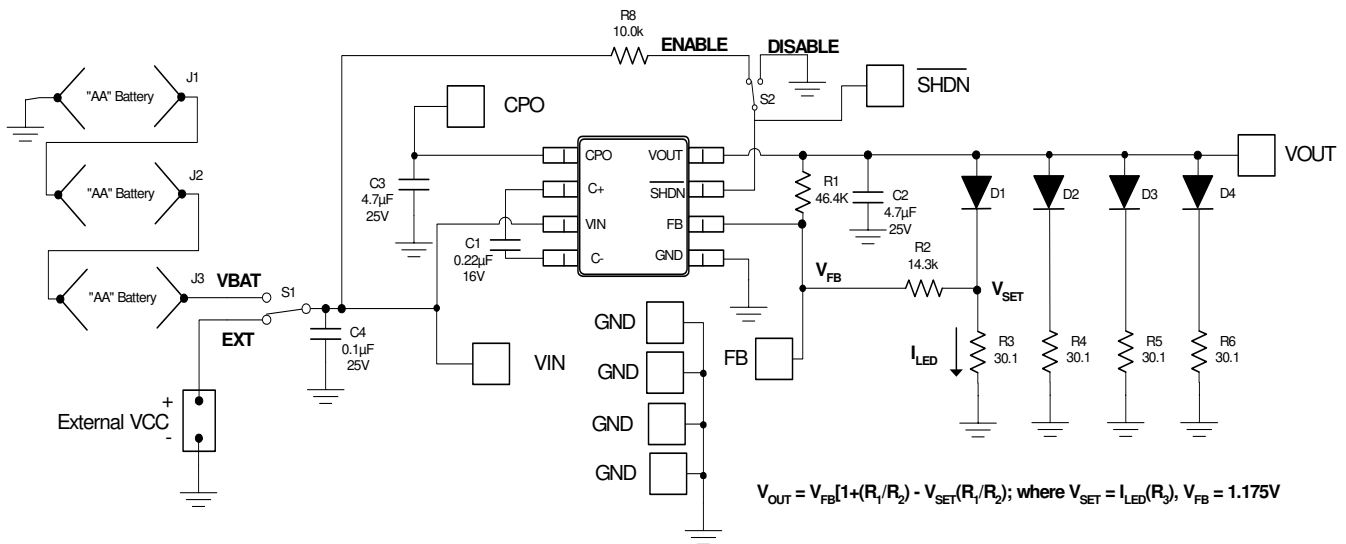


Figure 6 – LX1882-00 Evaluation Board Schematic; LED Driver Application

CHARACTERISTIC CURVES

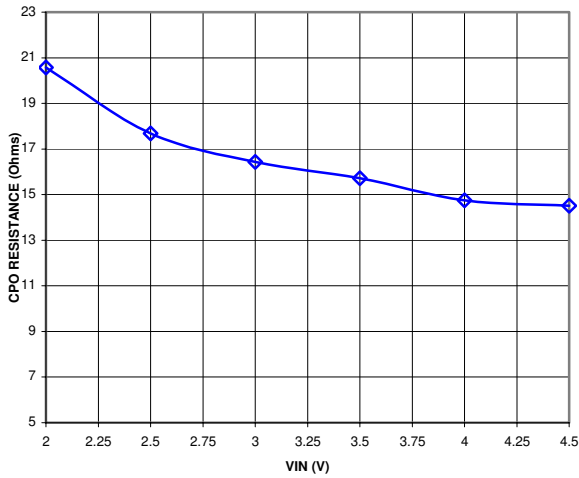


Figure 7 – CPO Output Resistance vs. Input Voltage;
 $T_A = 25^\circ\text{C}$, $C_1 = 0.22\mu\text{F}$, $C_2, C_3, C_4 = 4.7\mu\text{F}$, $C_{\text{FILT}} = 0.1\mu\text{F}$

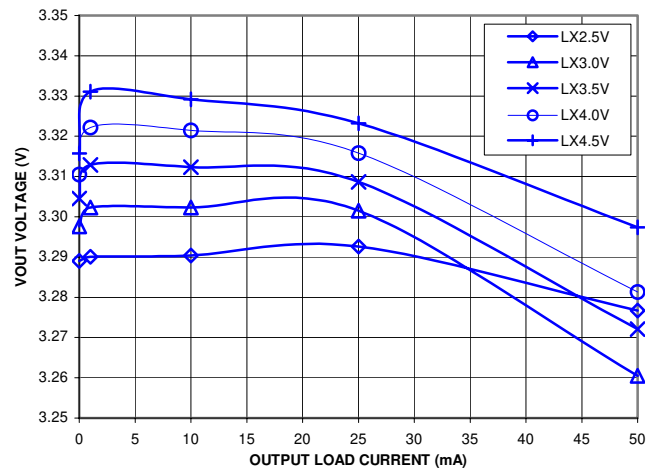


Figure 8 – LX1882-33 Output Voltage vs. Load Current;
 $T_A = 25^\circ\text{C}$, $C_1 = 0.22\mu\text{F}$, $C_2, C_3, C_4 = 4.7\mu\text{F}$, $C_{\text{FILT}} = 0.1\mu\text{F}$

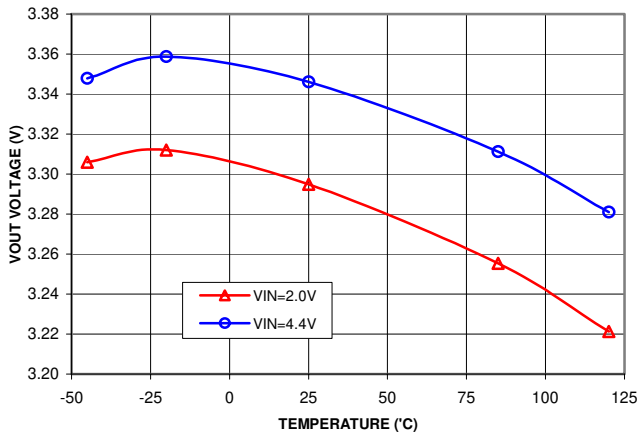


Figure 9 – LX1882-33 Output Voltage vs. Temperature;
 $C_1 = 0.22\mu\text{F}$, $C_2, C_3, C_4 = 4.7\mu\text{F}$, $C_{\text{FILT}} = 0.1\mu\text{F}$

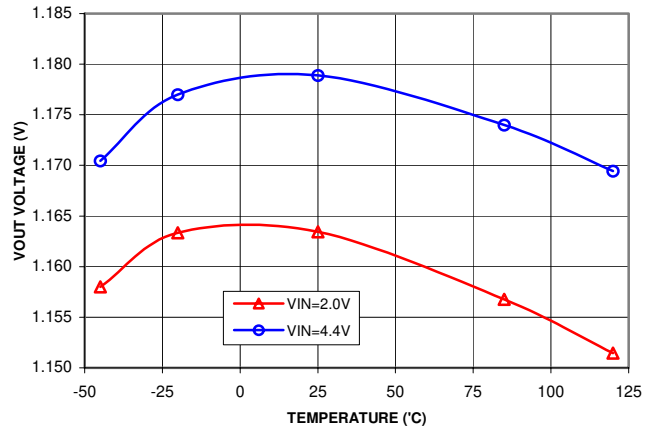


Figure 10 – LX1882-00 Output Voltage vs. Temperature;
 $C_1 = 0.22\mu\text{F}$, $C_2, C_3, C_4 = 4.7\mu\text{F}$

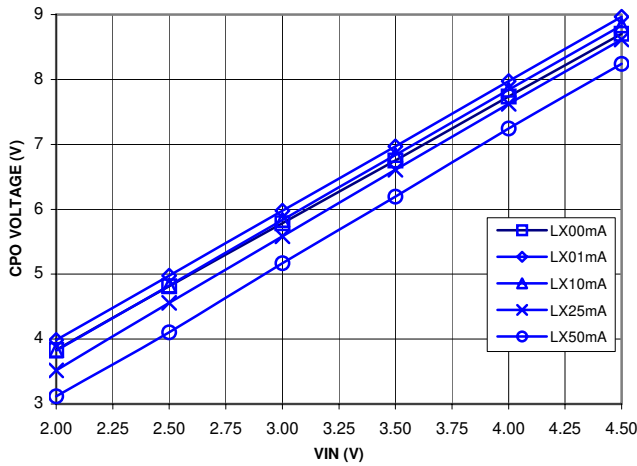
CHARACTERISTIC CURVES


Figure 11 – CPO Voltage vs. Input Voltage;
 $T_A = 25^\circ\text{C}$, $C_1 = 0.22\mu\text{F}$, $C_2, C_3, C_4 = 4.7\mu\text{F}$, $C_{\text{FILT}} = 0.1\mu\text{F}$

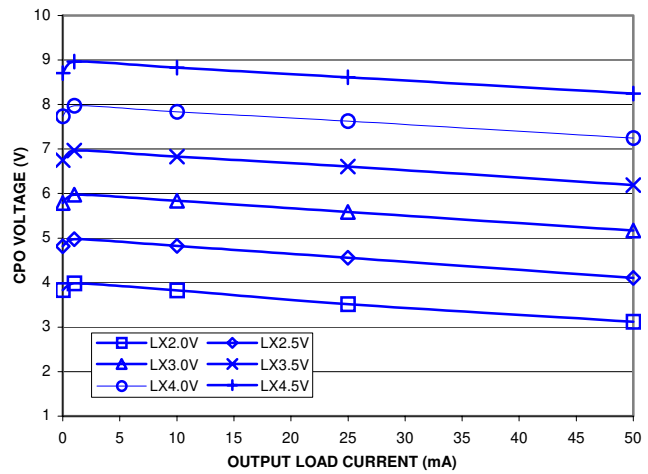


Figure 12 – CPO Voltage vs. Load Current;
 $T_A = 25^\circ\text{C}$, $C_1 = 0.22\mu\text{F}$, $C_2, C_3, C_4 = 4.7\mu\text{F}$, $C_{\text{FILT}} = 0.1\mu\text{F}$

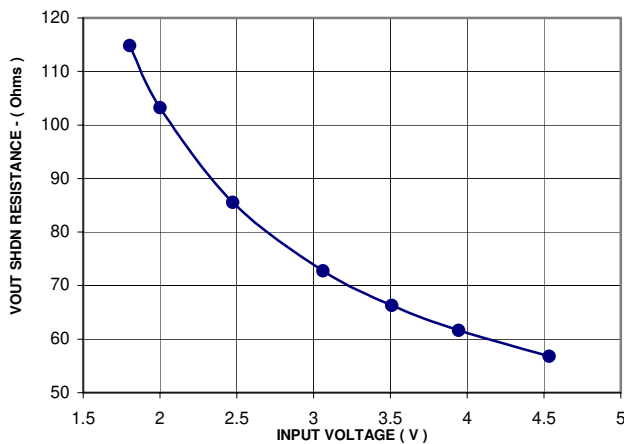


Figure 13 – V_{OUT} Shutdown Resistance vs. Input Voltage;
 $T_A = 25^\circ\text{C}$, $C_1 = 0.22\mu\text{F}$, $C_2, C_3, C_4 = 4.7\mu\text{F}$, $C_{\text{FILT}} = 0.1\mu\text{F}$

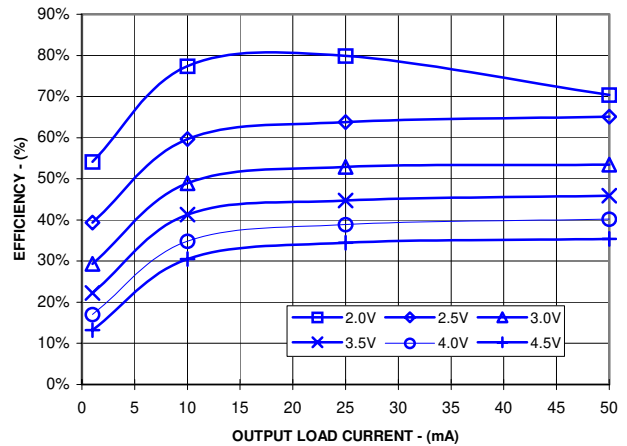
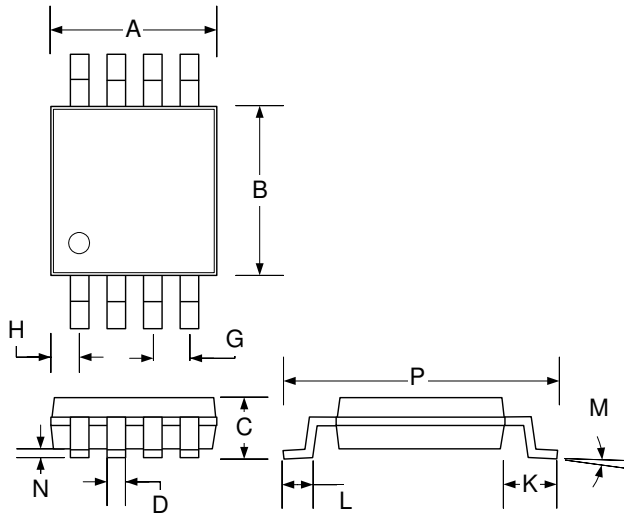
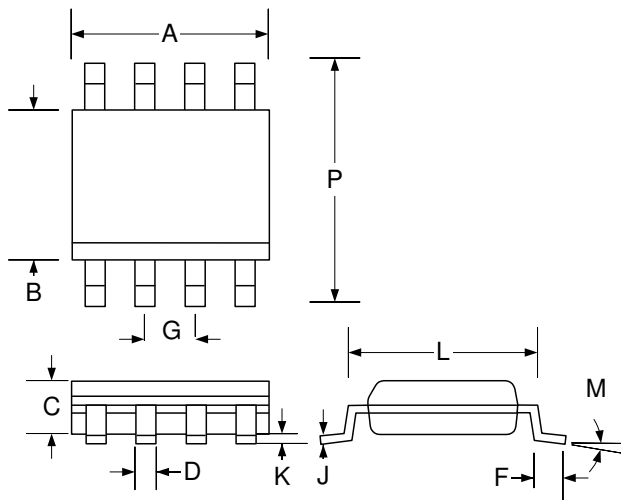


Figure 14 – Efficiency vs. Output Current;
 $T_A = 25^\circ\text{C}$, $C_1 = 0.22\mu\text{F}$, $C_2, C_3, C_4 = 4.7\mu\text{F}$, $C_{\text{FILT}} = 0.1\mu\text{F}$

MECHANICAL DRAWING
DU 8-Pin MSOP


Dim	MILLIMETERS		INCHES	
	MIN	MAX	MIN	MAX
A	2.85	3.05	.112	.120
B	2.90	3.10	.114	.122
C	-	1.10	-	0.043
D	0.25	0.40	0.009	0.160
G	0.65 BSC		0.025 BSC	
H	0.38	0.64	0.015	0.025
J	0.13	0.18	0.005	0.007
K	0.95 BSC		0.037 BSC	
L	0.40	0.70	0.016	0.027
M	3°		3°	
N	0.05	0.15	0.002	0.006
P	4.75	5.05	0.187	0.198

DM 8-Pin Plastic SOIC


Dim	MILLIMETERS		INCHES	
	MIN	MAX	MIN	MAX
A	4.83	5.00	0.190	0.197
B	3.81	3.94	0.150	0.155
C	1.35	1.75	0.053	0.069
D	0.33	0.51	0.013	0.020
F	-	0.77	-	0.030
G	1.27 BSC		0.050 BSC	
J	0.19	0.25	0.007	0.010
K	0.13	0.25	0.005	0.010
L	4.80	5.21	0.189	0.205
M	-	8°	-	8°
P	5.79	6.20	0.228	0.244
*LC	-	0.10	-	0.004

*Lead Coplanarity

Note:

- Dimensions do not include mold flash or protrusions; these shall not exceed 0.155mm(.006") on any side. Lead dimension shall not include solder coverage.



NOTES

PRODUCTION DATA – Information contained in this document is proprietary to Microsemi and is current as of publication date. This document may not be modified in any way without the express written consent of Microsemi. Product processing does not necessarily include testing of all parameters. Microsemi reserves the right to change the configuration and performance of the product and to discontinue product at any time.