

# MAXIM

## MAX1889 Evaluation Kit

**Evaluates: MAX1889**

### General Description

The MAX1889 evaluation kit (EV kit) is a fully assembled and tested surface-mount circuit board that contains a step-up switching regulator, a positive three-stage charge-pump and high-voltage positive linear-regulator controller, and a negative three-stage charge-pump and high-voltage negative linear-regulator controller. The step-up switching circuit is configured for a 9V output and provides up to 200mA from a DC supply voltage of 2.7V to 5.5V.

The positive charge-pump and linear regulator are configured for a 20V output using two charge-pump stages providing up to 10mA. The negative charge pump and linear regulator are configured for a -7V output using a single charge-pump stage providing up to 10mA. Power for the positive charge-pump input can be provided by the DC input source or the step-up switching regulator output. Power for the negative charge-pump input can be provided by the DC input source or the power ground.

The MAX1889 EV kit demonstrates low quiescent current and high efficiency (up to 90%) for maximum battery life. The EV kit features overload protection for the input and all outputs. Operation at 1MHz allows the use of tiny surface-mount components. The MAX1889 QFN package (1.0mm max) with low-profile external components allows this circuit to be 1.25mm high.

### Features

- ◆ 2.7V to 5.5V Input Range
- ◆ Output Voltages
  - 9V Output at 200mA (Step-Up Switching)
  - 20V Output >10mA (Positive Charge-Pump Regulator)
  - 7V Output >10mA (Negative Charge-Pump Regulator)
- ◆ Resistor-Adjustable Outputs
- ◆ Up to Three Positive and Three Negative Charge-Pump Stages
- ◆ Up to +28V and -22V Linear-Regulated Output (As Configured)
- ◆ 90% Efficiency
- ◆ 500kHz/1MHz Step-Up Switching Frequency
- ◆ Overcurrent Protection
- ◆ Low Profile
- ◆ Surface-Mount Components
- ◆ Fully Assembled and Tested

### Ordering Information

PART	TEMP RANGE	IC PACKAGE
MAX1889EVKIT	0°C to +70°C	16 QFN 5mm x 5mm

### Component List

DESIGNATION	QTY	DESCRIPTION
C1	1	0.47 $\mu$ F $\pm$ 10%, 16V X7R ceramic capacitor (0805) Taiyo Yuden EMK212BJ474KD
C2, C3	2	3.3 $\mu$ F $\pm$ 20%, 6.3V X5R ceramic capacitors (0805) Taiyo Yuden JMK212BJ335MG
C4, C5, C6	3	4.7 $\mu$ F $\pm$ 20%, 10V X7R ceramic capacitors (1210) Taiyo Yuden LMK325BJ475MF
C7	1	0.01 $\mu$ F $\pm$ 10%, 50V X7R ceramic capacitor (0603) TDK C1608X7R1H103K

DESIGNATION	QTY	DESCRIPTION
C8	1	220pF $\pm$ 10%, 50V COG ceramic capacitor (0603) TDK C1608COG1H221K
C9	1	0.22 $\mu$ F $\pm$ 10%, 10V X7R ceramic capacitor (0603) Taiyo Yuden LMK107BJ224KA
C10–C14, C17, C18, C19, C21, C22	10	0.1 $\mu$ F $\pm$ 10%, 50V X7R ceramic capacitors (0805) Taiyo Yuden UMK212BJ104KG
C15, C20	2	0.15 $\mu$ F $\pm$ 10%, 50V X7R ceramic capacitors (1206) Taiyo Yuden UMK316BJ154KF

# MAX1889 Evaluation Kit

Evaluates: MAX1889

## Component List (continued)

DESIGNATION	QTY	DESCRIPTION
C16, C23	2	1 $\mu$ F $\pm$ 10%, 25V X7R ceramic capacitors (0805) TDK C2012X7R1E105K
C24, C26, C28	3	1000pF $\pm$ 10%, 50V X7R ceramic capacitors (0603) TDK C1608X7R1H102K
C25	1	100 $\mu$ F $\pm$ 20%, 16V aluminum electrolytic capacitor (6.3mm x 5mm) Sanyo 16MV100UAX
C27	1	2200pF $\pm$ 10%, 50V X7R ceramic capacitor (0603) TDK C1608X7R1H222K
C29	1	470pF $\pm$ 10%, 50V X7R ceramic capacitor (0603) TDK C1608X7R1H471K
C30	1	100pF $\pm$ 10%, 50V COG ceramic capacitor (0603) TDK C1608COG1H101K
D1	1	1.0A, 30V Schottky diode (S-flat) Toshiba CRS02
D2–D7	6	200mA 25V Schottky diodes (SOT23) Fairchild BAT54S
D8	1	200mA 75V diode (SOT23) Fairchild MMBD4148
JU1, JU2	2	2-pin headers
JU3, JU8	2	3-pin headers
JU4–JU7	4	4-pin headers
L1	1	4.7 $\mu$ H, 1.6A inductor Coilcraft Inc. LPO2506IB-472

DESIGNATION	QTY	DESCRIPTION
P1	1	2.4A, -20V P-channel MOSFET (3-pin SuperSOT) Fairchild FDN304P
P2	0	Not installed MOSFET ( $\mu$ 8)
Q1	1	200mA, 40V NPN bipolar transistor (SOT23) Fairchild MMBT3904
Q2	1	200mA, 40V PNP bipolar transistor (SOT23) Fairchild MMBT3906
R1	1	51.1k $\Omega$ $\pm$ 1% resistor (0805)
R2, R10, R20	3	150k $\Omega$ $\pm$ 1% resistors (0805)
R3, R4, R7	3	1M $\Omega$ $\pm$ 5% resistors (0805)
R5	1	76.8k $\Omega$ $\pm$ 1% resistor (0805)
R6	1	12.1k $\Omega$ $\pm$ 1% resistor (0805)
R8	1	10k $\Omega$ $\pm$ 5% resistor (0805)
R9, R12	2	3k $\Omega$ $\pm$ 5% resistors (0805)
R11	1	24.3k $\Omega$ $\pm$ 1% resistor (0805)
R13	1	301k $\Omega$ $\pm$ 1% resistor (0805)
R14, R18	2	20k $\Omega$ $\pm$ 1% resistors (0805)
R15	1	10 $\Omega$ $\pm$ 5% resistor (0805)
R16	1	220k $\Omega$ $\pm$ 5% resistor (0805)
R17	1	15k $\Omega$ $\pm$ 5% resistor (0805)
R19	1	43.2k $\Omega$ $\pm$ 1% resistor (0805)
R21	1	Not installed resistor (0603)
U1	1	MAX1889EGE (16-pin QFN 5mm x 5mm)
None	8	Shunts (JU1–JU8)
None	1	MAX1889 PC board
None	1	MAX1889 data sheet
None	1	MAX1889 EV kit data sheet

## Component Suppliers

SUPPLIER	PHONE	FAX	WEBSITE
Coilcraft	847-639-6400	847-639-1469	www.coilcraft.com
Fairchild	408-822-2000	408-822-2102	www.fairchildsemi.com
Sanyo	619-661-6322	619-661-1055	www.sanyovideo.com
Taiyo Yuden	800-348-2496	847-925-0899	www.t-yuden.com
TDK	847-803-6100	847-390-4405	www.component.tdk.com
Toshiba	949-455-2000	949-859-3963	www.toshiba.com/taec

**Note:** Please indicate that you are using the MAX1889 when contacting these component suppliers.

# MAX1889 Evaluation Kit

## Quick Start

### Recommended Equipment

- 2.7V to 5.5V, 2A DC power supply
- One voltmeter

### Procedure

The MAX1889 EV kit is fully assembled and tested. Follow these steps to verify board operation. **Do not turn on the power supply until all connections are completed:**

- 1) Verify that there are no shunts across jumpers JU1 (SHDN), JU2 (FREQ), JU3, JU4, and JU8.
- 2) Verify that a shunt is across pins 1 and 2 of JU7.
- 3) Verify that a shunt is across pins 1 and 3 of JU6.
- 4) Verify that a shunt is across pins 1 and 4 of JU5.
- 5) Connect the positive terminal of the input power supply to the PIN pad. Connect the negative terminal of the input power supply to the PGND pad.
- 6) Turn on the power supply and verify that the step-up regulator output (VBST) is 9V.
- 7) Verify that the positive linear-regulator output (VPL) is 20V.
- 8) Verify that the negative linear-regulator output (VNL) is -7V.

For instructions on selecting the feedback resistors for other output voltages, see the *Output Voltage Selection* section.

## Detailed Description

The MAX1889 EV kit contains a step-up switching regulator and two linear-regulator controllers. It operates from a DC power supply between 2.7V and 5.5V. The switching frequency is selectable between 500kHz and 1MHz. The input and outputs of the EV kit are protected against overload. The EV kit features a shutdown mode for maximum battery life.

As configured, the step-up switching regulator generates a 9V output and can provide at least 200mA of current to the output. The step-up switching-regulator output voltage can be adjusted from the input voltage up to 13V with resistors (see the *Output Voltage Selection* section).

As configured, the positive charge pump uses two of the three charge-pump stages to generate approximately 24V and can provide greater than 10mA. The output is post-regulated to 20V using a linear-regulator controller and an external bipolar pass transistor. The positive linear regulator's output can be adjusted between 1.25V and 28V or, with additional circuitry, to even higher voltages (refer to the *Linear-Regulator Controllers* section in the MAX1889 data sheet).

As configured, the negative charge pump uses one of the three charge-pump stages to generate approximately -7.6V and can provide greater than 10mA. The output is post-regulated to -7V using a linear-regulator controller and an external bipolar pass transistor. The negative linear regulator's output can be adjusted between 0 and -22V or, with additional circuitry, to even lower voltages (refer to the *Linear-Regulator Controllers* section in the MAX1889 data sheet).

The EV kit includes input-current overload protection that shuts down the circuit if the input current exceeds a threshold for longer than 64ms. The threshold is set by resistor-divider R1, R2, R19, R20, and the  $R_{DS(ON)}$  of MOSFET P1 or P2. Refer to the *Setting the Input Overcurrent Threshold* section in the MAX1889 data sheet for further details. The EV kit also includes output overload protection that shuts down the circuit if any of the output voltages drop below approximately 80% of their nominal value for longer than 64ms.

## Jumper Selection

### Shutdown Mode

The MAX1889 EV kit features a shutdown mode that reduces the MAX1889 quiescent current to less than 1 $\mu$ A. The 2-pin jumper, JU1, selects the shutdown mode for the MAX1889 EV kit. Table 1 lists the selectable jumper options.

**Caution: Do not connect an external controller to the SHDN pad while a shunt is on JU1 since the external controller can be damaged.**

### Frequency Mode

The MAX1889 EV kit features an option to choose the switching frequency. JU2 selects the frequency mode for the MAX1889 EV kit. Table 2 lists the selectable jumper options. The EV kit is configured for 1MHz operation. Optimum performance at 500kHz requires a larger inductor value (refer to the *Inductor Selection* section in the MAX1889 data sheet.)

### Positive Charge Pump

The positive charge pump of the MAX1889 EV kit features an option to cascade up to three stages of charge pumps. Each stage of the charge pump can be powered from INPUT, VBST, or the previous stage. JU8, JU7, and JU6 configure the number of stages and select the voltage source for the positive charge pump on the MAX1889 EV kit. Tables 3, 4, and 5 list the jumper options. The default configuration of the positive charge pump of the MAX1889 EV kit is a two-stage charge pump powered from VBST as indicated in Tables 4 and 5. Refer to the *Charge Pumps* section of the MAX1889 data sheet for information on selecting a charge-pump configuration.

# MAX1889 Evaluation Kit

**Table 1. JU1 Functions**

SHUNT LOCATION	SHDN PIN	MAX1889 EV KIT OUTPUT
Installed	Connected to PGND	Shutdown mode
None	Connected to IN through R3	MAX1889 enabled
None	External controller connected to SHDN pad	Logic high (IN) = enabled, logic low (PGND) = disabled

**Table 3. JU8 Functions**

SHUNT LOCATION	FIRST STAGE POSITIVE CHARGE PUMP	OPERATING MODE
1-2	Connected to VBST	First stage of a three-stage charge pump powered by VBST
2-3	Connected to INPUT	First stage of a three-stage charge pump powered by INPUT
None	Not used	Not used for one-stage or two-stage charge pumps

### Negative Charge Pump

The negative charge pump of the MAX1889 EV kit features an option to cascade up to three stages of charge pumps. Each stage of the charge pump can be powered from INPUT, PGND, or the previous stage. JU3, JU4, and JU5 configure the number of stages and select the voltage source for the negative charge pump on the MAX1889 EV kit. Tables 6, 7, and 8 list the jumper options. The default configuration of the negative charge pump of the MAX1889 EV kit is a one-stage charge pump powered from PGND as indicated in Table 8. Refer to the *Charge Pumps* section of the MAX1889 data sheet for information on selecting a charge-pump configuration.

**Table 2. JU2 Functions**

SHUNT LOCATION	FREQ PIN	MAX1889 EV KIT FREQUENCY
Installed	Connected to PGND	Frequency = 500KHz
None	Connected to IN through R4	Frequency = 1MHz

**Table 4. JU7 Functions**

SHUNT LOCATION	SECOND STAGE POSITIVE CHARGE PUMP	OPERATING MODE
1-2 (Default)	Connected to VBST	First stage of a two-stage charge pump powered by VBST
1-3	Connected to previous stage charge-pump output	Second stage of a three-stage charge pump
1-4	Connected to INPUT	First stage of a two-stage charge pump powered by INPUT
None	Not used	Not used for one-stage charge pumps

### Output Voltage Selection

#### Step-Up Switching-Regulator Output Voltage

The MAX1889 EV kit's step-up switching-regulator output is set to 9V by feedback resistors R5 and R6. To generate output voltages other than 9V (up to 13V), select different external voltage-divider resistors (R5, R6). The output capacitors (C4, C5, and C6) are rated to 10V. To set the output voltage greater than 10V, use higher-voltage rated capacitors. Refer to the *Main Step-Up Regulator, Output Voltage Selection* section in the MAX1889 data sheet for instructions on selecting the resistors.

# MAX1889 Evaluation Kit

Evaluates: MAX1889

**Table 5. JU6 Functions**

SHUNT LOCATION	THIRD STAGE POSITIVE CHARGE PUMP	OPERATING MODE
1-2	Connected to VBST	One-stage charge pump powered by VBST
1-3 (Default)	Connected to previous stage charge-pump output	Last stage of a two-stage or three-stage charge pump
1-4	Connected to INPUT	One-stage charge pump powered by INPUT

**Table 6. JU3 Functions**

SHUNT LOCATION	FIRST STAGE NEGATIVE CHARGE PUMP	OPERATING MODE
1-2	Connected to INPUT	First stage of a three-stage charge pump powered by INPUT
2-3	Connected to PGND	First stage of a three-stage charge pump powered by PGND
None	Not used	Not used for one-stage or two-stage charge pump

**Table 7. JU4 Functions**

SHUNT LOCATION	SECOND STAGE NEGATIVE CHARGE PUMP	OPERATING MODE
1-2	Connected to INPUT	First stage of a two-stage charge pump powered by INPUT
1-3	Connected to previous stage charge-pump output	Second stage of a three-stage charge pump
1-4	Connected to PGND	First stage of a two-stage charge pump powered by PGND
None	Not used	Not used for one-stage charge pump

**Table 8. JU5 Functions**

SHUNT LOCATION	THIRD STAGE NEGATIVE CHARGE PUMP	OPERATING MODE
1-2	Connected to INPUT	One-stage charge pump powered by INPUT
1-3	Connected to previous stage charge-pump output	Last stage of a two-stage or three-stage charge pump
1-4 (Default)	Connected to PGND	One-stage charge pump powered by PGND

### **Positive Linear-Regulator Output Voltage**

The MAX1889 EV kit's positive linear-regulator output is set to 20V by feedback resistors R13 and R14. To generate output voltages other than 20V (1.25V to 28V), select different external voltage-divider resistors (R13, R14). Refer to the *Linear-Regulator Controllers, Output Voltage Selection* section in the MAX1889 data sheet for instructions on selecting the resistors.

### **Negative Linear-Regulator Output Voltage**

The MAX1889 EV kit's negative linear-regulator output is set to -7V by feedback resistors R10 and R11. To generate output voltages other than -7V (0 to -22V), select different external voltage-divider resistors (R10, R11). Refer to the *Linear-Regulator Controllers, Output Voltage Selection* section in the MAX1889 data sheet for instructions on selecting the resistors.

# MAX1889 Evaluation Kit

Evaluates: MAX1889

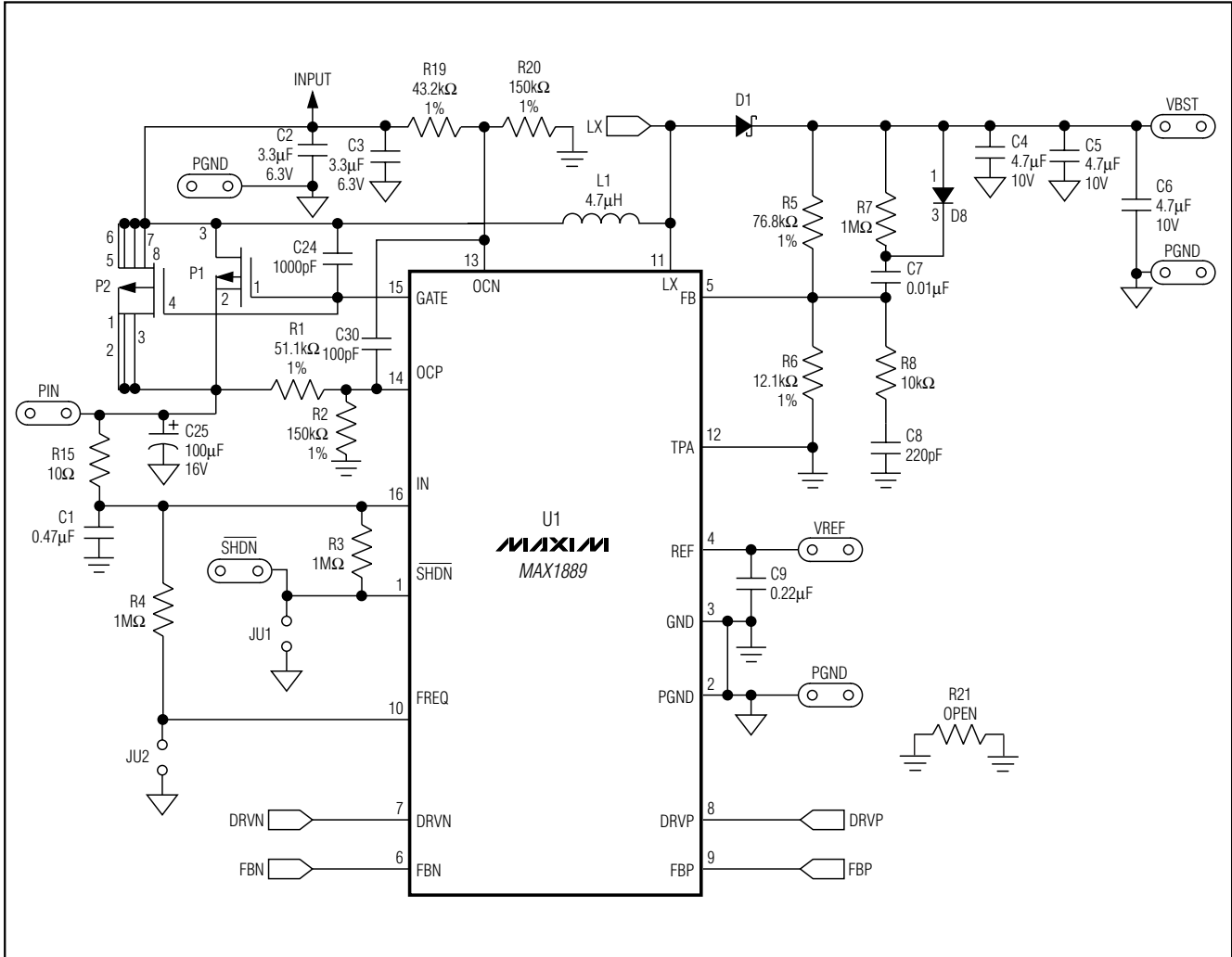

Figure 1. MAX1889 EV Kit Schematic (Sheet 1 of 2)

# MAX1889 Evaluation Kit

Evaluates: MAX1889

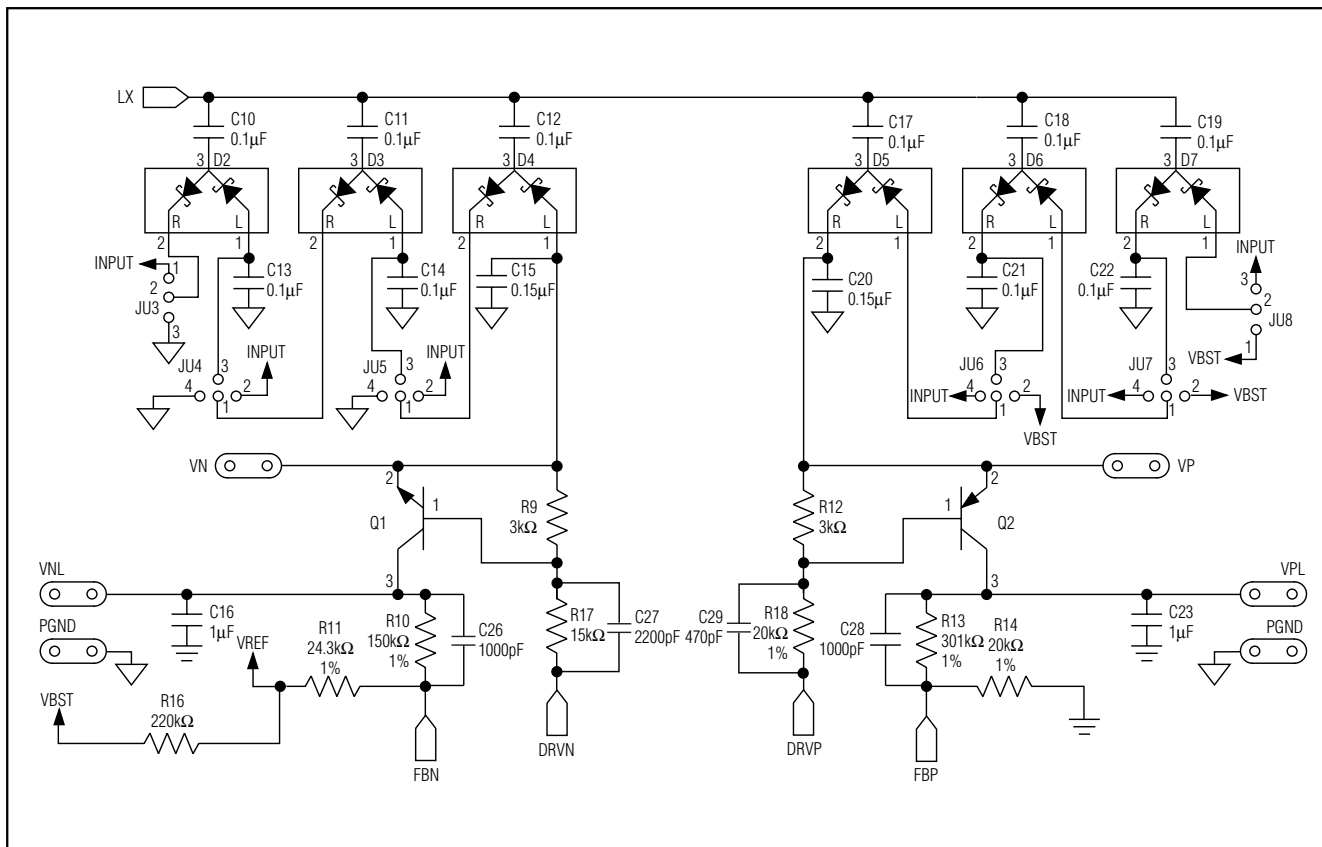

Figure 1. MAX1889 EV Kit Schematic (Sheet 2 of 2)

# MAX1889 Evaluation Kit

**Evaluates: MAX1889**

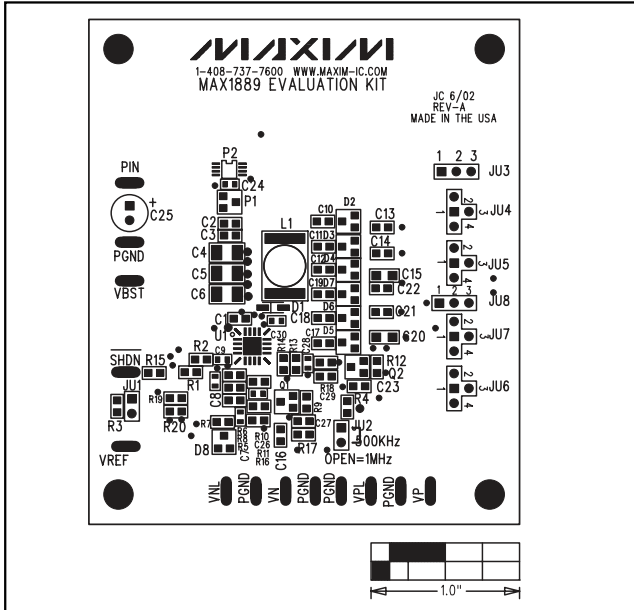

Figure 2. MAX1889 EV Kit Component Placement Guide—Component Side

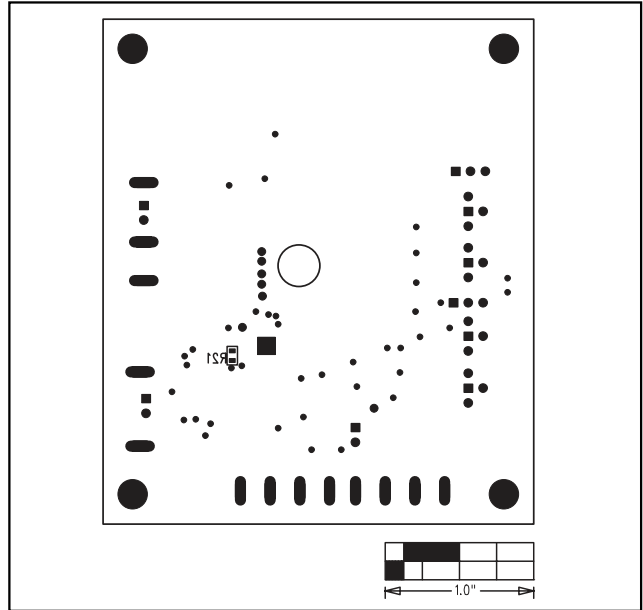

Figure 3. MAX1889 EV Kit Component Placement Guide—Solder Side

