

PART NUMBER	CONTACT PLATING	HOUSING FINISH
E3FSW	SILVER	SATIN NICKEL
E3FAUSW	GOLD	SATIN NICKEL
E3FBSW	SILVER	BLACK CHROME WITH CHEMICAL TREATMENT
E3FBAUSW	GOLD	BLACK CHROME WITH CHEMICAL TREATMENT

NOTE: ADD SUFFIX "EL" TO ABOVE PART NUMBERS FOR FIXED, NON-REMOVABLE CONNECTOR INSERT VERSION.

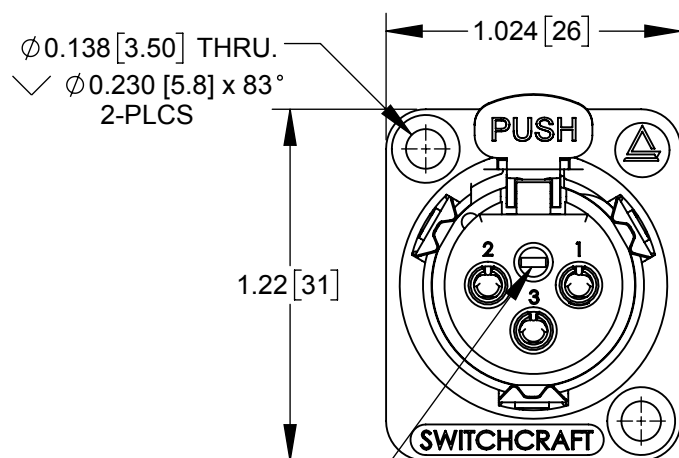

FRONT VIEW

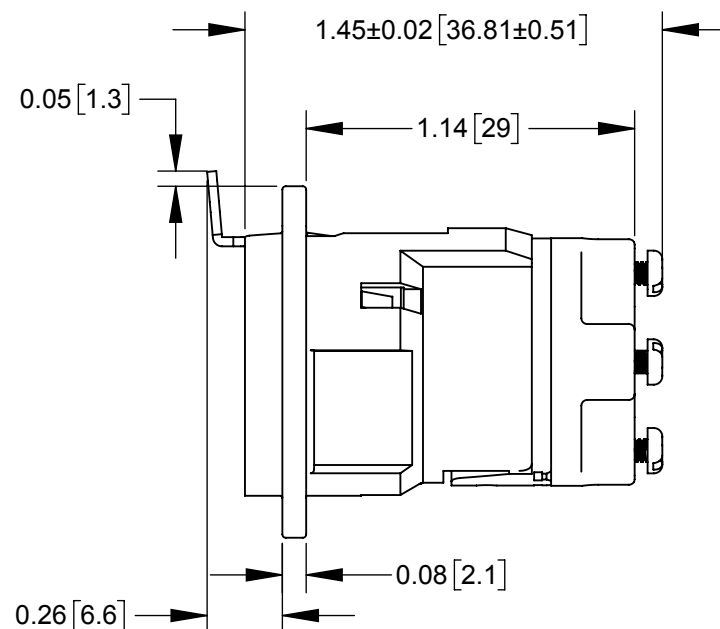

REAR (WIRING) VIEW

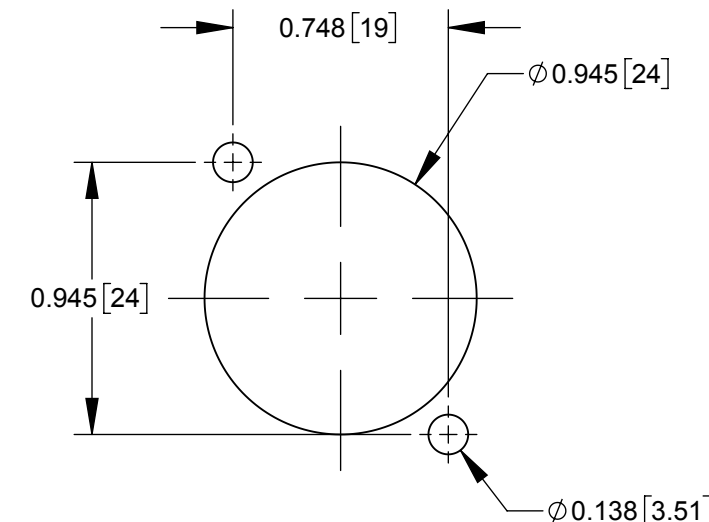
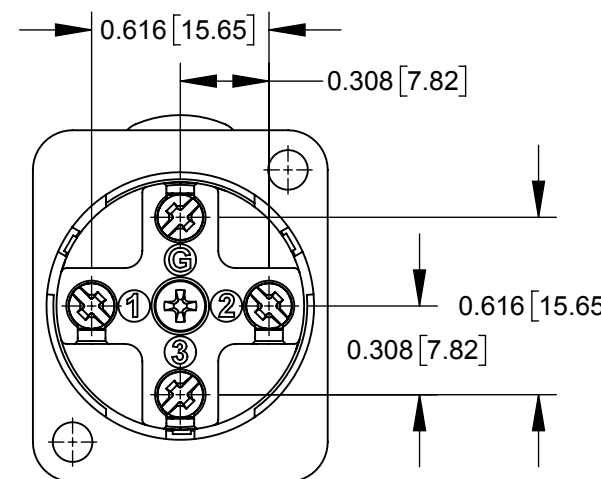

RECOMMENDED PANEL CUT-OUT

INSERT LOCKING SCREW
SEE NOTE 4

NOTES:

- MATERIAL:**
SHELL - DIE CAST ZINC ALLOY, SATIN NICKEL OR BLACK CHROME FINISH
INSULATOR INSERT, TERMINAL COVER - THERMOPLASTIC
CONTACTS, TERMINAL POST - COPPER ALLOY, SILVER OR GOLD PLATED
LATCH RELEASE - STEEL, NICKEL PLATED
INSERT LOCKING CAM - DIE CAST ZINC ALLOY
SCREWS - STAINLESS STEEL
- PLATING SPECIFICATIONS:**
SILVER PLATE: 0.000120" [0.0003mm]
GOLD PLATE: 0.00002" [0.000508mm] GOLD OVER 0.0002" [0.00508mm] NICKEL
- WIRING INSTRUCTIONS:**
TERMINALS ACCEPT 16 TO 26 AWG SOLID OR STRANDED WIRE CONDUCTORS.
RECOMMENDED STRIP & TIN LENGTH: 0.188" [4.8mm] TO 0.218" [5.5mm].
RECOMMENDED SCREW TERMINAL TORQUE: 2 in-lb [0.226 Nm] MAXIMUM.
- CLOCKWISE TURNING OF LOCKING SCREW SECURES INSERT IN HOUSING, COUNTERCLOCKWISE TURNING RELEASES INSERT. DOES NOT APPLY TO NON-REMOVABLE INSERT VERSION CONNECTORS DENOTED BY SUFFIX "EL" IN THE PART NUMBER.**
- THESE PRODUCTS ARE RoHS COMPLIANT.

CUSTOMER DRAWING

REVISIONS					UNLESS OTHERWISE SPECIFIED					THIS DRAWING DESCRIBES A DESIGN CONSIDERED PROPRIETARY IN NATURE, DEVELOPED AND MANUFACTURED BY SWITCHCRAFT INC. AND IS RELEASED ON A CONFIDENTIAL BASIS FOR IDENTIFICATION PURPOSES ONLY.				
0B	PROJECT 08025	05/04/12	PNK	SRC	1. ALL DIMENSIONS IN INCHES - TWO PLACE DECIMALS ±0.02 - THREE PLACE DECIMALS ±0.005	SIZE	WIDTH	MULT	LBS/M	TEMPER	MATERIAL SPEC No.			
0A	PROJECT 08025	02/14/12	PNK	SRC		FINISH	SCALE 1.5:1							
REV	ECO NUMBER	DATE	BY	APVD		DATE DRAWN	BY	CHKD	APVD	SHEET 1 OF 1				
					DO NOT SCALE DRAWING	E3F SERIES, SCREW TERMINALS, RoHS					PART No. E3F_SW SERIES		REV 0B	