

DSCA33

Isolated True RMS Input Signal Conditioners



Description

Each DSCA33 True RMS input module provides a single channel of AC input which is converted to its True RMS DC value, filtered, isolated, amplified, and converted to standard process voltage or current output (Figure 1).

The field voltage or current input signal is processed through an AC coupled pre-amplifier and RMS converter on the field side of the isolation barrier. The converted dc signal is then filtered and chopped by a proprietary chopper circuit and transferred across the transformer isolation barrier, suppressing transmission of common mode spikes and surges. The computer side circuitry reconstructs, filters and converts the signal to industry standard outputs.

Module output is either voltage or current. For current output models a dedicated loop supply is provided at terminal 3 (+OUT) with loop return located at terminal 4 (-OUT). The system-side load may be either floating or grounded.

Special input circuits provide protection against accidental connection of power-line voltages up to 480VAC and against transient events as defined by ANSI/IEEE C37.90.1. Protection circuits are also present on the signal output and power input terminals to guard against transient events and power reversal. Signal and power lines are secured to the module using screw terminals which are pluggable terminal blocks for ease of system assembly and reconfiguration.

DSCA33 modules have excellent stability over time and do not require recalibration, however, both zero and span settings are adjustable to accommodate situations where fine tuning is desired. The adjustments are made using potentiometers located under the front panel label and are non-interactive for ease of use.

Due to circuit limitations, DSCA33-04x and -05x are not ATEX compliant.

Features

- Interfaces RMS Voltage (0 – 300V) or RMS Current (0 – 5A)
- Designed for Standard Operation with Frequencies of 45Hz to 1000Hz (Extended Range Operation to 20kHz)
- Compatible with Standard Current and Potential Transformers
- Industry Standard Output of 0 to 1mA, 0 to 20mA, 4 to 20mA, 0 to +5V, or 0 to +10V
- ±0.25% Factory Calibrated Accuracy (Accuracy Class 0.2)
- ±5% Adjustable Zero and Span
- 1500Vrms Transformer Isolation
- Input Overload Protected to 480V (Peak AC & DC) or 10Arms Continuous
- 100dB CMR
- ANSI/IEEE C37.90.1 Transient Protection
- Easily Mounts on Standard DIN Rail
- C-UL-US Listed and CE Compliant
- ATEX Compliant (all models except DSCA33-04x, -05x)

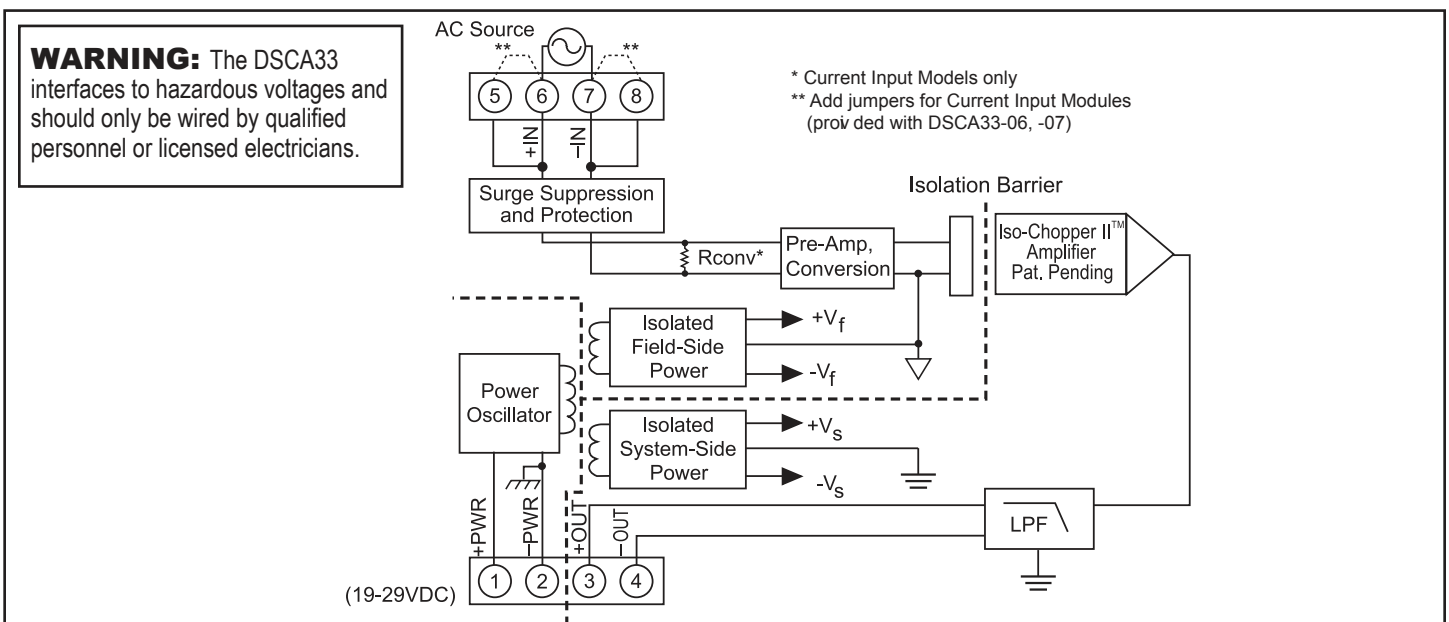

Figure 1: DSCA33 Block Diagram

Specifications Typical* at T_A = +25°C and +24VDC supply voltage

Module	DSCA33
Input Signal Range Standard Frequency Range Extended Frequency Range Impedance Coupling Protection Continuous (-01 thru -05) Continuous (-06 thru -07) Transient (-01 thru -05) Transient (-06 thru -07)	100mV to 300Vrms, 0 to 5Arms 45Hz to 1000Hz 1kHz to 20kHz 499KΩ // <100pF (-01 thru -05), 0.10Ω (-06), 0.025Ω (-07) AC 350Vrms 5Arms (-06), 10Arms (-07) max ANSI/IEEE C37.90.1 See note 1
Output Signal Range Adjustability Load Resistance Current Limit Protection Short to Ground Transient Ripple and Noise	See Ordering Information ±5% Zero & Span 10kΩ max. (0-1mA models), 600Ω max. (0/4-20mA models) 1.4mA (0-1mA models), 30mA (0/4-20mA models), 8mA (0-5/10V models) Continuous ANSI/IEEE C37.90.1 ⌀ .025% Span rms
Accuracy (10-100% Span)^{(2) (3)} Sinusoid 50/60Hz 45Hz-1kHz 1kHz-20kHz Non-Sinusoid Crest Factor = 1 to 2 Crest Factor = 2 to 3 Crest Factor = 3 to 4 Crest Factor = 4 to 5 Vs. Temperature	±0.25% Span ±0.25% Reading Additional Error ±0.75% Reading Additional Error ±0.05% Reading Additional Error ±0.15% Reading Additional Error ±0.30% Reading Additional Error ±0.40% Reading Additional Error ±100ppm/°C
Isolation (Common Mode) Input to Output, Input to Power Continuous Transient Output to Power Continuous	1500Vrms max ANSI/IEEE C37.90.1 50VDC max
Response Time (0 to 99%)	4 00ms
CMR (50 or 60Hz)	100dB
Power Supply Voltage Current Sensitivity Protection Reverse Polarity Transient	19 to 29VDC 45mA (V _{OUT}), 65mA (I _{OUT}) ±0.0002% % Continuous ANSI/IEEE C37.90.1
Mechanical Dimensions (h)(w)(d)	2.95" x 0.89" x 4.13" (75mm x 22.5mm x 105mm)
Mounting	DIN EN50022 -35x7.5 or -35x15 rail
Environmental Operating Temperature Range Storage Temperature Range Relative Humidity HazLoc ATEX Emissions EN61000-6-4 Radiated, Conducted Immunity EN61000-6-2 RF ESD, EFT	-40°C to +80°C -40°C to +80°C 0 to 95% Noncondensing All models except DSCA33-04x, -05x ISM, Group 1 Class A ISM, Group 1 Performance A ±0.83% Span Error Performance B

NOTES:

*Contact factory or your local Dataforth sales office for maximum values.

 (1) For 1 to 25 seconds the max allowable transient current rating is $\sqrt{2500}$ / (event time). For less than 1 second, ANSI/IEEE C37.90.1 applies with a 0.05Ω load. For greater than 25 seconds, the 10A max continuous rating applies.

(2) For 0-10% Span measurements, add 0.25% accuracy error (-02 thru -07) or 1.00% accuracy error (-01). Accuracy includes linearity, hysteresis and repeatability but not source or external shunt inaccuracy (if used).

(3) At standard 60Hz factory calibration (90Hz for -01, -06). Consult factory for calibration at other frequencies.

Ordering Information

Model	Input (rms) [†]	Output (dc) [†]
DSCA33-01	0mV to 100mV	2, 3, 4, 5, 6
DSCA33-02	0V to 1V	2, 3, 4, 5, 6
DSCA33-03	0V to 10V	2, 3, 4, 5, 6
DSCA33-04	0V to 150V	2, 3, 4, 5, 6
DSCA33-05	0V to 300V	2, 3, 4, 5, 6
DSCA33-06	0A to 1A	2, 3, 4, 5, 6
DSCA33-07	0A to 5A	2, 3, 4, 5, 6

 †Modules can be ordered with other input/output ranges.
 Consult factory for ordering details and specifications

†Output Ranges Available

Output Range	Part No. Suffix	Example
2. 0V to +10V	NONE	DSCA33-01
3. 4 to 20mA	C	DSCA33-01C
4. 0 to 20mA	E	DSCA33-01E
5. 0V to +5V	A	DSCA33-01A
6. 0 to 1mA	B	DSCA33-01B

Installation Notes:

- 1.) This Equipment is Suitable for Use in Class I, Division 2, Groups A, B, C, D, or Non-Hazardous Locations Only.
- 2.) WARNING - Explosion Hazard - Substitution of Components May Impair Suitability for Class I, Division 2.
- 3.) WARNING - Explosion Hazard - Do Not Disconnect Equipment Unless Power Has Been Switched Off or The Area is Known to be Non-Hazardous.
- 4.) The Power to These Devices Shall Be Limited By an Over-Current Protection Device, UL Certified Fuse (JDYX/JDYX2) Rated 6A Max.