

**UG0048**  
**User Guide**  
**ProASIC3/E Starter Kit**





**Power Matters.™**

**Microsemi Corporate Headquarters**

One Enterprise, Aliso Viejo,  
CA 92656 USA

Within the USA: +1 (800) 713-4113

Outside the USA: +1 (949) 380-6100

Fax: +1 (949) 215-4996

Email: [sales.support@microsemi.com](mailto:sales.support@microsemi.com)

[www.microsemi.com](http://www.microsemi.com)

© 2017 Microsemi Corporation. All rights reserved. Microsemi and the Microsemi logo are trademarks of Microsemi Corporation. All other trademarks and service marks are the property of their respective owners.

Microsemi makes no warranty, representation, or guarantee regarding the information contained herein or the suitability of its products and services for any particular purpose, nor does Microsemi assume any liability whatsoever arising out of the application or use of any product or circuit. The products sold hereunder and any other products sold by Microsemi have been subject to limited testing and should not be used in conjunction with mission-critical equipment or applications. Any performance specifications are believed to be reliable but are not verified, and Buyer must conduct and complete all performance and other testing of the products, alone and together with, or installed in, any end-products. Buyer shall not rely on any data and performance specifications or parameters provided by Microsemi. It is the Buyer's responsibility to independently determine suitability of any products and to test and verify the same. The information provided by Microsemi hereunder is provided "as is, where is" and with all faults, and the entire risk associated with such information is entirely with the Buyer. Microsemi does not grant, explicitly or implicitly, to any party any patent rights, licenses, or any other IP rights, whether with regard to such information itself or anything described by such information. Information provided in this document is proprietary to Microsemi, and Microsemi reserves the right to make any changes to the information in this document or to any products and services at any time without notice.

**About Microsemi**

Microsemi Corporation (Nasdaq: MSCC) offers a comprehensive portfolio of semiconductor and system solutions for aerospace & defense, communications, data center and industrial markets. Products include high-performance and radiation-hardened analog mixed-signal integrated circuits, FPGAs, SoCs and ASICs; power management products; timing and synchronization devices and precise time solutions, setting the world's standard for time; voice processing devices; RF solutions; discrete components; enterprise storage and communication solutions, security technologies and scalable anti-tamper products; Ethernet solutions; Power-over-Ethernet ICs and midspans; as well as custom design capabilities and services. Microsemi is headquartered in Aliso Viejo, California, and has approximately 4,800 employees globally. Learn more at [www.microsemi.com](http://www.microsemi.com).

# Contents

---

<b>1</b>	<b>Revision History</b>	<b>1</b>
1.1	Revision 5.1	1
1.2	Revision 5.0	1
1.3	Revision 4.0	1
1.4	Revision 3.0	1
<b>2</b>	<b>Contents and System Requirements</b>	<b>2</b>
2.1	Kit Contents	2
<b>3</b>	<b>Hardware Components</b>	<b>3</b>
3.1	ProASIC3/E Starter Kit Board	3
3.2	Board Description and Usage	4
3.3	PLL Parts and Usage on ProASIC3/E	4
3.3.1	Instructions for PLL Activation on Board	5
3.4	Power Supply	5
3.4.1	Power Supply Connections of Daughter Card	6
3.4.2	Power Supplies and Chaining Boards Together	7
3.5	Programming the ProASIC3/E Device with FlashPro	8
3.5.1	Connecting the FlashPro4 Programmer to the Board	8
3.5.2	Programming or Re-Programming the Design	8
3.5.3	Jumpers for Isolating Switches and LEDs from FPGA	9
3.6	Clock Circuits	10
3.6.1	40 MHz Oscillator	10
3.7	LED Device Connections	10
3.8	Switches Device Connections	11
3.9	LVDS Channels	11
<b>4</b>	<b>Setup and Self Test</b>	<b>14</b>
4.1	Software Installation	14
4.2	Hardware Installation	14
4.3	Testing the Starter Kit Board	14
4.4	Programming the Test File	14
<b>5</b>	<b>Description of Test Design</b>	<b>15</b>
<b>6</b>	<b>LVDS Signal Evaluation</b>	<b>17</b>
6.1	Hardware Test Setup	17
6.2	Design Test Setup	17
6.3	Measurement Results	18
<b>7</b>	<b>Testing the Board</b>	<b>19</b>
7.1	Equipment Required	19
7.1.1	Equipment Provided to Testing Facility	19
7.1.2	Testing Facility Equipment	19
7.2	Test Procedure for the A3PE-STARTER-KIT-2	19
7.2.1	Initial Power-On Procedure	19
7.2.2	Testing Board Functionality with A3PE1500-PQ208 Silicon	20
<b>8</b>	<b>Appendix: PQ208 Package Connections</b>	<b>22</b>

8.1	I/O Naming Conventions .....	22
8.2	208-Pin PQFP .....	23
<b>9</b>	<b>Appendix: Board Schematics .....</b>	<b>26</b>
9.1	Top-Level View .....	27
9.2	ProASIC3/E Starter Kit Board Schematics .....	29

# Figures

---

Figure 1	ProASIC3/E Starter Kit Board: Top-Level View	4
Figure 2	Power Supply Block Diagram	5
Figure 3	Design Block Diagram	15
Figure 4	Data Block Diagram	16
Figure 5	TX Portion of Test Design	17
Figure 6	LVDS Signal across RX Termination at 300 Mbps	18
Figure 7	208-Pin PQFP	23
Figure 8	Top-Level View of ProASIC3/E Starter Kit Board	27
Figure 9	Bottom-Level View of ProASIC3/E Starter Kit Board	28
Figure 10	Bottom-Level View of ProASIC3/E Starter Kit Board	29
Figure 11	ProASIC3 FPGA	30
Figure 12	Push-Button and Hex Switches	31
Figure 13	FPGA Headers and Expansion Bus	32
Figure 14	Clocks Oscillators and Reset	33
Figure 15	Decoupling Caps, Test Points	34
Figure 16	LVDS Signal Routing Via CAT-5E Connectors	35

# Tables

---

Table 1	Kit Contents .....	2
Table 2	Summary of Jumpers .....	9
Table 3	LED Device Connections .....	11
Table 4	Switch Device Connections .....	11
Table 5	Color Convention on CAT 5E Primary .....	12
Table 6	Color Convention on CAT 5E Secondary .....	12
Table 7	FPGA – LVDS I/O Pin Details .....	13
Table 8	Switches .....	16
Table 9	Device Connections for 208-Pin PQFP .....	24

# 1 Revision History

---

The revision history describes the changes that were implemented in the document. The changes are listed by revision, starting with the most current publication.

## 1.1 Revision 5.1

Component description, connection section of OLED, OLED manufacturing test, and board image are updated.

## 1.2 Revision 5.0

The following was a summary of the changes in revision 5.0 of this document.

- The part number for the ProASIC3/E Starter Kit was changed from A3PE-STARTER-KIT to A3PE-STARTER-KIT-2 (SAR 42164).
- In the "FPGA – OLED Interface" section, PMO13701 was corrected to PMO18701 (SAR 42164).

## 1.3 Revision 4.0

Libero IDE software has been updated to Libero SoC throughout the document (SAR 36951).

## 1.4 Revision 3.0

The silicon for this kit has been updated, so the document has been updated accordingly (SAR 27883).

## 2 Contents and System Requirements

---

This section details the contents of the ProASIC3/E Starter Kit and lists the power supply and software system requirements.

### 2.1 Kit Contents

The following table lists the contents of the ProASIC3/E Starter Kit.

**Table 1 • Kit Contents**

<b>Item</b>	<b>Quantity</b>
ProsASIC3/E Starter Kit Board with an A3PE1500-PQG208	1
FlashPro4 programmer	1
9 V power supply with international adapters	1
Quickstart card	1



## 3 Hardware Components

---

This section describes the hardware components of the ProASIC3/E Starter Kit board.

### 3.1 ProASIC3/E Starter Kit Board

Figure 1, page 4 illustrates a top-level view of the ProASIC3/E Starter Kit board.

The ProASIC3/E Starter Kit board consists of the following:

- Wall mount power supply connector, with a switch and a LED indicator
- Switches to select from among 1.5 V, 1.8 V, 2.5 V, and 3.3 V — I/O voltages on banks 4 and 5 (southern side)
- 10-pin 0.1 inch pitch programming connector compatible with Altera connections
- 40 MHz oscillator and two independent manual clock options for global reset and pulse
- Eight LEDs (driven by outputs from the device)
- Jumpers (allow disconnection of all external circuitry from the FPGA)
- Two mono stable pulse generator switches (global and reset)
- Four switches (provide input to the device)
- Two hex switches to provide four inputs each to the FPGA, and which are set to a user-switchable hexadecimal input value

For more information, see [Appendix: PQ208 Package Connections](#), page 22 and [Appendix: Board Schematics](#), page 26.

## 3.2 Board Description and Usage

The ProASIC3/E Starter Kit board is socketed and is populated with A3PE1500-PQ208 silicon. Any ProASIC3 device can be used, as all devices in both the ProASIC3 and ProASIC3E families are available in the PQ208 package.

**Note:** Device Pin-out is different among ProASIC3 and ProASIC3E device families. For more information about pinouts, see <https://www.microsemi.com/products/fpga-soc/fpga/proasic3-e#documents>.

A block diagram of the ProASIC3/E Starter kit board is shown in the following figure and will facilitate understanding of the more detailed schematics shown in the [Appendix: Board Schematics](#), page 26.

**Figure 1 • ProASIC3/E Starter Kit Board: Top-Level View**

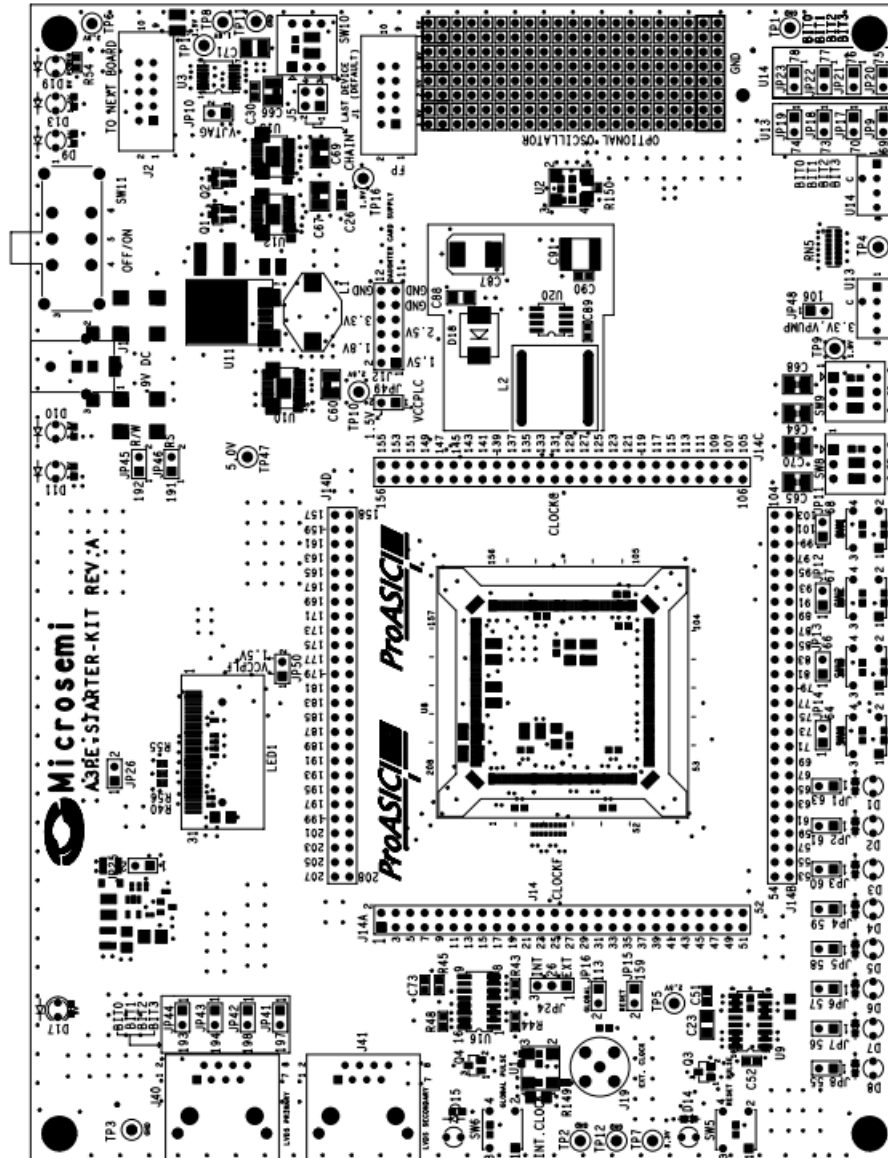

Full schematics are available for download from the Microsemi SoC Products Group website. The electronic versions of the dedicated schematics can be enlarged to a far greater degree than shown in the printed version of this manual or even in the electronic version of this manual, hence the interested reader is referred to the dedicated schematics to see the appropriate level of detail.

## 3.3 PLL Parts and Usage on ProASIC3/E

This section describes the PLL parts and usage on ProASIC3/E.

### 3.3.1 Instructions for PLL Activation on Board

In order to use the PLLs on the ProASIC3/E Starter Kit board, power must be applied to their respective analog supply rails. For the west side PLL, known as PLF, the VCCPLF line must be connected to VCC, which is held at 1.5 V. The same is true for VCCPLC of the PLL on the east side, known as PLC. In addition, the VCOMPLF and VCOMPLC lines must be connected to ground. The jumpers JP49 and JP50 are provided on the starter kit to connect VCCPLF and VCCPLC pins to 1.5 V supply.

The ground pins of the PLL supplies are connected to ground on the board. These supply voltages are not connected by default on the board for three reasons:

1. The PLC analog voltage rails are not available on ProASIC3 devices; only on ProASIC3E in the PQ208 package. Only the west side PLL, namely PLF, is available on ProASIC3 devices in PQ208. In ProASIC3 devices, the pins are used as general I/Os. The same board is used for ProASIC3E and ProASIC3 devices.
2. To demonstrate the lowest possible power consumption for the part. Perpetually powering the PLL lines would not achieve that.
3. It is easy to place a jumper on the appropriate jumper header when desired.

## 3.4 Power Supply

A 9 V power supply is provided with the kit, as shown in the following figure. There are many power supply components in the starter kit board to illustrate the many ways that differing voltage banks may be supported with ProASIC3 and ProASIC3E technology. These voltage banks are not required for general usage of ProASIC3 silicon. They are provided purely for illustrative purposes.

**Note:** The latest revision of ProASIC3/E Starter Kit (A3PE-STARTER-KIT-2) does not have an OLED populated on the board.

**Figure 2 • Power Supply Block Diagram**

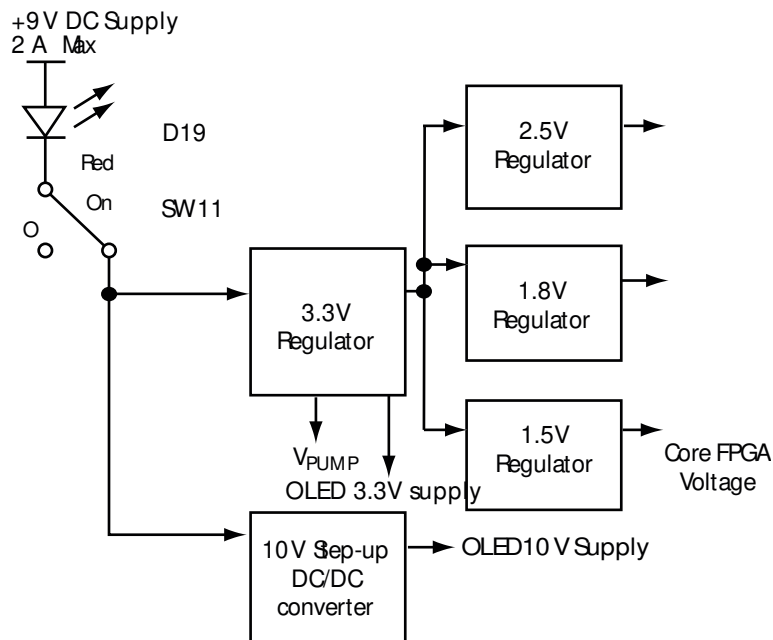

To use the ProASIC3/E Starter Kit board with a wall mount power supply, use the switching brick power supply that is provided with the kit.

The external +9 V positive center power supply provided to the board through connector J18 goes to a voltage regulator chip U11 on the Starter Kit board. As soon as the external voltage is connected to the

board, the red LED D19 illuminates to indicate that an external supply is connected to the board. As soon as switch SW11 is moved to the ON position (to the right, as labeled on the board OFF/ON), the disabling ground signal is removed from pin 7 of U11 and the regulator begins to provide power at its output.

The U11 switching voltage regulator provides a dedicated 3.3 V supply at its output. The board's 3.3 V supply is used for feeding separate regulators that deliver 1.5 V (through U15), 1.8 V (through U12), and 2.5 V (through U15). The 1.5 V is required for the core voltage of the ProASIC3/E family, and the 2.5 V is required for demonstrating LVDS extended I/O bank capability.

The presence of these voltages is indicated by four green LEDs (D13, D9, D10, and D11) illuminating at the top right of the board. Each LED is labeled with the voltage it represents and its component identifier. All four voltages are selectable on the I/O banks 4 and 5 (the two southernmost banks) of a ProASIC3E device using SW9 and SW8 switches respectively.

**Note:** Only ProASIC3E devices have eight I/O banks. ProASIC3 devices have four I/O banks—one per side of the PQ208 package. If a ProASIC3 device is placed in the socket, then both SW8 and SW9 should be set at same voltage level to power I/O bank 2.

The 3.3 V supply is also used for optionally providing the VPUMP programming voltage. This VPUMP voltage may be provided to the chip during programming by applying a FlashPro4 programmer to the J1 interface and selecting VPUMP from the FlashPro v9.1 (or later) programming software. VPUMP voltage may also be provided directly to the chip from the board.

Leave the JP48 jumper in place to apply 3.3 V supply to the VPUMP pin (106 of the PQ208 packaged FPGA).

**Note:** If both FlashPro4 or latest and the board are selected to provide VPUMP, then it is the connection on the board that will override, as FlashPro4 will detect that a voltage is available, issue an information message in the programming software, and then move the VPUMP output pin to a tristate value, allowing the board to provide all the power.

The board must be powered-up during programming because the chip needs its core voltages to be provided and VJTAG must be detected by the FlashPro4 programmer in order for it to set its JTAG signal voltages to the right level.

The OLED device requires low current 10 V supply and 3.3 V supply to operate correctly. These voltages are provided by LT1615 and LM2678S modules, as shown in [Figure 16](#), page 35.

The external +9 V power supply is rated at 2 A maximum. On the first of the full-page dedicated schematics shown in the [Appendix: Board Schematics](#), page 26, note that the 3.3 V supply is rated at 5 A maximum. The derived power supplies of 1.5 V, 1.8 V, and 2.5 V are rated at 2 A max each, and the OLED 10 V power supply is rated at 100 mA, as shown in [Figure 16](#), page 35. Clearly, not all these derived supplies can be working at their respective maximum current outputs simultaneously. The maximum ratings are for the individual regulator ICs and cannot be numerically added together.

The U11 (LM2678S-3.3) component is rated for an input voltage range of +8 V to +40 V, so a wide range of power supplies may be used with the board with no concern about over-voltage conditions occurring from inadvertent accidental usage of the wrong power supply. However, the user must ensure that the voltage provided is positive at the center pin of the J18 connector and grounded on the outside. Greater heating of the regulator chips can be observed with higher voltages. It is recommended that only the included power supply or an equivalent substitute be used with the Starter Kit. The included power supply has been rated for this board, including Microsemi SoC Products Group Daughter Cards that may be attached to the board.

### 3.4.1 Power Supply Connections of Daughter Card

Limited power is supplied to a daughter card by the board. The connector for the daughter card is shown in [Figure 13](#), page 32 and is the J12 header. All the FPGA voltages 1.5 V, 1.8 V, 2.5 V, and 3.3 V are provided to the daughter card through a 12-pin 0.1 inch pitch connector. The voltages are arranged with a no-connection pin interspersing the voltage pins. This prevents accidental use of a jumper to short a supply rail to ground, which could connect differing supply rails together.

The purpose is not to protect the power supply regulators, as these will go high-impedance when an over-voltage condition is detected. It is to protect the FPGA from unintentional application of a higher

voltage to the 1.5 V core. Three of the twelve pins are ground pins, which will provide more than sufficient current return capability for future Microsemi SoC Products Group daughter cards that will work with this board.

## 3.4.2 Power Supplies and Chaining Boards Together

When joining multiple ProASIC3/E Starter Kit boards together through the chain programming connection, J2 connector is used to connect the J1 connector of the next board in the chain by attaching a standard 0.100-inch pitch 10-pin programming cable. The length of the cable must be kept as short as possible, because multiple boards connected form a JTAG chain of ProASIC3/E devices can provide much greater noise pick-up and may degrade the TCK clock for devices remote from the FlashPro4 programmer. A rotary switch SW10 is provided on the board to set the VJTAG supply. Select the VJTAG supply between 1.5 V, 1.8 V, 2.5 V, and 3.3 V using SW10. Set VJTAG at an absolute minimum of 1.8 V to help with signal integrity when chaining boards together. Higher voltages can give better noise and impedance mismatch immunity.

Disconnect the jumper at JP10 on all boards. This jumper can be used to provide VJTAG to a downstream board or to some element in the design that you wish to supply with the VJTAG voltage used by the ProASIC3/E component. The shunt that is normally in this location can be safely stored across pins 11 and 12, or 9 and 10 of the J12 daughter card power supply connector. For particularly long chains, the value of TCK used during programming must be reduced.

During the development, various revisions of the ProASIC3/E Starter Kit board are produced. This documentation contains additional text that documents some of these earlier versions, as well as the newest version of the board. The latest version of the board A3PE-STARTER-KIT-2 REV B does not have OLED display. A3PE-STARTER-KIT-2 REV A version is same as A3PE-PROTO-KIT except the LCD display is replaced with an OLED display and all the components are RoHS compliant. Schematics for Rev3 and Rev2 boards are the same when viewed as PDF files, but there is a short in the board layers on the Rev2 that has been corrected for Rev3. The rare Rev1 prototype boards had different schematics and are not discussed in this document.

### 3.4.2.1 Procedure for Rev A Boards

To determine if the board is a Starter Kit Rev A board: A Rev A board is recognized by examining the front of the board and looking for the part number just beneath the large Microsemi corporate logo on the board top silk-screen. The part number is A3PE-STARTER-KIT-2 followed by REV A.

To chain Starter Kit Rev A boards together: All boards from the board nearest the FlashPro4 programmer must have the shunt that is placed by default on pins 3 and 4 of the J5 header moved to connect pins 1 and 2. On the board and schematic CHAIN (pins 1 and 2) and LAST DEVICE (DEFAULT) (pins 3 and 4) are labeled clearly. Only the last board in the chain must have the shunt remaining across pins 3 and 4 of the J5 connector.

**Note:** If there is only one board in the chain then it, by definition, is the last board and should have the shunt at J5 connecting pins 3 and 4. This is why this position is labeled as the DEFAULT position for a typical customer with a single starter kit board.

### 3.4.2.2 Procedure for Rev3 Boards

To determine if the board is a Rev3 board: A Rev3 board is recognized by examining the front of the board and looking for the part number just beneath the large Microsemi SoC Products Group corporate logo on the board top silk-screen. The part number is A3PE-A3P-EVAL-BRD1 followed by REV3.

**To chain Rev3 boards together:** Treat it as Starter Kit Rev A board in the previous section.

### 3.4.2.3 Procedure for Rev2 Boards (With and Without Rework)

To determine if the board is a Rev2 board: A Rev2 board is indicated by a red LED in the upper right corner of the board and a part number underneath the Microsemi SoC Products Group corporate logo on the board top silk-screen. The part number is A3PE-A3P-EVAL-BRD1. No additional text is followed with the board number. If the board is reworked to force it to become equivalent to a Rev3 board, it contains a green wire on the top side of the board. If it does not contain green wire, it is Rev2.

To chain Rev2 boards together: If reworked, treat it as Rev3 in the previous section. If not reworked, then chaining of the boards cannot be done. The shunt on J5 must be removed for any programming to take place.

#### 3.4.2.4 Procedure for Rev1 Boards

To determine if the board is a Rev1 board: A Rev1 board is indicated by no red LED in the upper right corner of the board. The part number on the board top silk-screen is A3PE-EVAL-BRD600.

**Note:** Rev1 boards should not be used with this user guide or with design files included with this Starter Kit as the schematics are incompatible with current commercial boards.

VPUMP connections when chaining boards together: When these boards are connected through a connection from J2 of one board to J1 of another board, VPUMP will be connected from one board to another. When powering on one board with a connector in place, notice that the 1.5 V, 1.8 V, 2.5 V, and 3.3 V LEDs will light on the board to which no power has been applied. The FPGA on that board, if it is programmed, will start operating. This is clearly an inappropriate situation for a large chain of boards. This is caused by having the JP48 connector for supplying VPUMP from the board connected on other boards in the chain, as VPUMP is itself connected to the 3.3 V supply output that is used to generate the other FPGA voltages on a board. To prevent VPUMP from being used as the source of a 3.3 V supply, remove the shunt that is in place on the JP48 connector to force JP48 to be open-circuit. To prevent loss of the shunt, it may be safely stored on the J12 header for the daughter card power supply as it is impossible to cause a short by joining any adjacent pins.

### 3.5 Programming the ProASIC3/E Device with FlashPro

The base board used for all ProASIC3/E starter kits is A3PE-A3P-EVAL-BRD1.

The A3PE-STARTER-KIT-2 and A3PE-PROTO-KIT boards are socketed and are populated with A3PE1500 silicon. Any device in the ProASIC3/E family in the PQ208 package can be placed into the socket.

In a kit with a socket on the board, a reasonable number of insertions may be made if the user exercises great care in inserting components into the socket.

**Note:** Screw-down sockets are not clam shell sockets, and do have a lifetime of about 20 insertions, although far greater may be achieved with careful placement and use of a torque-limiting screwdriver. Placement of the FPGA in the socket is critical, to ensure all pins are correctly connected.

#### 3.5.1 Connecting the FlashPro4 Programmer to the Board

Connect the FlashPro4 programmer to your computer through the USB cable. For installing the software and connecting to FlashPro4, see the *FlashPro User Guide*. The amber (yellow) power LED on the FlashPro4 must be illuminated at this stage. If it is not, recheck the procedure in the FlashPro User Guide until you obtain a steady amber (yellow) power LED illumination.

Ensure the board power switch, SW11 is in the OFF position, and only the red board external power LED is illuminated on the board.

Connect the FlashPro4 programmer to the board through the 10-pin programming cable supplied with the FlashPro4 programmer hardware. The connector to use on the board is labeled FP and is the lower J1 shrouded and keyed header. The pin 1 location on the cable indicated by the red ribbon running along the side of the cable can be on the left side as it enters into the board. After connecting the FlashPro4 programmer, select **Analyze Chain** from the File menu in the FlashPro software. If all is well, the appropriate device ID for the ProASIC3 or ProASIC3E part shows in the software display on the PC. If there is a JTAG communication issue, try changing the VJTAG voltage. For overcoming noise, higher values usually work better, but all values must work with the supplied programming cable (6 inches in length) with connection to just one board.

#### 3.5.2 Programming or Re-Programming the Design

Download the latest version of the ProASIC3/E starter kit example design at:

<https://www.microsemi.com/products/fpga-soc/design-resources/dev-kits/proasic3/proasic3-starter-kit#documents>.



Using FlashPro software, program the example design on ProASIC3/E device.

### 3.5.3 Jumpers for Isolating Switches and LEDs from FPGA

Many jumpers are provided on the board to allow the user to disconnect various switch combinations or LEDs from the FPGA I/O banks. All such jumpers are shown in the schematic in [Figure 8](#), page 27 and are labeled on the top-layer silkscreen as JP\* where \* is a number. All jumpers are also labeled with the FPGA I/O pin number to which they are connected; example, JP48 for the 3.3 V connection of VPUMP to the FPGA is labeled with 106, which indicates that it is connected to pin 106. Similarly, SW4 has a jumper above it called JP14, which is labeled with 64, indicating that SW4 is connected through to pin 64 of the FPGA when this jumper is in place.

Disconnecting the jumpers JP11, JP12, JP13, and JP14 causes the momentary push-button switches (SW1, SW2, SW3, and SW4) to be disconnected from the FPGA so that the I/O pins 68, 67, 66, and 64 are used for other purposes. Disconnecting the eight jumpers, JP1 through JP8, causes the eight light emitting diodes (D1 through D8) to be disconnected from the FPGA I/O pins 63, 61, 60, 59, 58, 57, 56, and 55, respectively.

The momentary push-button switches (SW5 and SW6, for applying a reset pulse and a global pulse) are connected through jumpers JP15 and JP16 to I/Os 159 and 113 respectively. All labeling is clearly shown on the silk screen.

The hex switches U13 and U14 each are connected to four I/Os on the FPGA. There are four separate jumpers for each of these hex switches, located on the bottom right of the board. They are labeled with Bit0, Bit1, Bit2, and Bit3 on the silk screen, as well as being labeled with the I/O pin on the FPGA to which each is connected.

This allows individually control the desired effect of a switch and, by connecting directly to the FPGA side of a disconnected jumper, hold a particular pin at a chosen logic level while continuing to use the hex switch to affect other pins. This flexibility is useful for experimentation with designs of your own choosing and connecting other external equipment to the board for development purposes.

The internal and external oscillator selection through JP24 is worth a mention. JP24 is a three-pin header onto which a normal two-hole shunt is fitted. Normally, the shunt is connected across pins 3 and 2 of JP24. In this position the on-board oscillator, U1, provides the internal clock to the middle pin of the jumper which in turn is connected to pin 26 of the FPGA. By moving the shunt down to connect pins 2 and 1 of JP24, the external clock at pin 1 is connected to the FPGA instead. The external clock is connected through the SMA connector J19 at the bottom left of the board.

The following table lists the jumpers available on the board with their description.

**Table 2 • Summary of Jumpers**

Jumper	Description
JP1 to JP8	To connect LEDs (LED1 to LED8) to FPGA
JP10	VJTAG enable/disable
JP11 to JP14	To connect push-button switches (SW1, SW2, SW3, and SW4) to FPGA
JP15 and JP16	To connect momentary push-button switches SW5 and SW6 to FPGA
JP9 and JP17 to JP19	To connect hex switch (U13) to FPGA
JP20 to JP23	To connect hex switch (U14) to FPGA
JP24	On-board or external clock source selection
JP48	VPUMP voltage
JP49	VCCPLC – Power supply to the east side PLL
JP50	VCCPLF – Power supply to the west side PLL

### 3.5.3.1 Test Points

All test points on the board are fitted with small test loops. These test points are labeled on the silkscreen as TP1, TP2, and so on. All such test points are also labeled on the silk screen with the voltage expected to be observed at that test point. Voltages will be one of 3.3 V, 2.5 V, 1.8 V, 1.5 V, or GND. When measuring the voltage at a test point with a DVM (digital voltage multimeter), the ground lead must be connected to a test point labeled GND and the voltage lead must be connected to the voltage to be tested. All voltage labels on the board are relative to a 0 V ground reference or GND.

### 3.5.3.2 Prototyping Area

The prototyping area to the right of the board has the bottom two rows of pins connected to ground, labeled as GND on the silk screen and enclosed in a box, giving 16 holes connected to 0 V. The top two rows of pins are connected to various power supply rails internally in the board.

They are grouped into squares of four pins from left to right as follows: 3.3 V, 2.5 V, 1.8 V, and 1.5 V, giving four holes for each voltage level. All other holes in the prototyping area are unconnected and may be used to hold various discrete components as necessary for experimentation.

Next to the prototyping area is U2, which is a space for an optional oscillator. This space may be used for fitting a second oscillator to the board, similar to the one used at U1, so as to provide two different frequency clocks to the FPGA.

On the reverse side of the board, there is an area labeled U5, which is a TQ100 pattern with some surrounding pads. This area is used to solder a TQ100 part, and then connect that part by adding discrete wires to the pads and connecting it to desired pins on the board. The main purpose of this is to allow a previously programmed TQ100 packaged device to be used to provide a more interesting system application.

### 3.5.3.3 Layering on Board

The complete board design and manufacturing files are available at:

<https://www.microsemi.com/products/fpga-soc/design-resources/dev-kits/proasic3/proasic3-starter-kit#documents>.

The board file is in allegro format, which allows an end user to create the appropriate Gerbers and other board views as needed.

The board is fabricated with 6 layers of copper. The layers are arranged as follows from the top of the board down to the bottom:

- Layer 1: Top signal layer
- Layer 2: Ground plane
- Layer 3: Signal layer 3, used for LVDS receive and other signals
- Layer 4: Signal layer 4, used for LVDS transmit and other signals
- Layer 5: Power plane
- Layer 6: Bottom signal layer

**Note:** For signal integrity that the two LVDS layers are sandwiched between ground and power planes to isolate them as best as possible from external influences.

## 3.6 Clock Circuits

The ProASIC3/E Starter Kit board has two clock circuits: a 40 MHz oscillator and a manual clock.

### 3.6.1 40 MHz Oscillator

The 40 MHz oscillator on the board is a 10 ppm stability crystal module which gives good LVDS performance. For better stability, an external oscillator is provided through the SMA connector. Typically, a TCXO gives 1 ppm stability and an OCXO gives 0.1 ppm stability. Both the default on-board oscillator and the SMA are connected to the CLK F input of the west bank of the FPGA. Position is also provided on the board for mounting a second crystal oscillator module connected to the CLK C input of the FPGA on the east bank.



## 3.7 LED Device Connections

Eight LEDs are connected to the device through jumpers JP1 to JP8. If the jumpers are in place, the device I/O can drive the LEDs. The LEDs change based on the following output:

- A 1 on the output of the device lights the LED
- A 0 on the output of the device switches off the LED
- An un-programmed or tristated output may show a faintly lit LED

**Note:** If the I/O voltage of Bank 5 (on ProASIC3, set by SW8) or Bank 2 (ProASIC3E set by SW8 and SW7 being at the same level) is not at least 2.5 V, the LEDs will not illuminate. A setting of 1.8 V on the voltage bank will cause extremely faint illumination.

The following table lists the LED and device connections. To use the device I/O for other purposes, remove the jumpers.

**Table 3 • LED Device Connections**

LED	Device Connection
D1	U8 Pin 63
D2	U8 Pin 61
D3	U8 Pin 60
D4	U8 Pin 59
D5	U8 Pin 58
D6	U8 Pin 57
D7	U8 Pin 56
D8	U8 Pin 55

## 3.8 Switches Device Connections

Four switches are connected to the device through jumpers JP11 to JP14. If the jumpers are in place, the device I/O can be driven by the switches listed in the following table.

- Pressing a switch drives a 1 into the device. The 1 continues to drive while the switch is in place.
- Releasing a switch drives a zero into the device.

To use the device I/O for other purposes, remove the jumpers.

**Table 4 • Switch Device Connections**

Switch	Device Connections
SW1	U8 Pin 68
SW2	U8 Pin 67
SW3	U8 Pin 66
SW4	U8 Pin 64

## 3.9 LVDS Channels

Four LVDS channels with up to a maximum signaling rate of 350 MHz are supported on the Starter Kit board. These LVDS signals are brought out to a pair of RJ-45 (CAT-5E) sockets (J40 and J41). For the position of these connectors, see [Figure 1](#), page 4.

The LVDS signals are driven using 8 differential pairs (consisting of 16 I/O pins) from the west side (Bank6 and Bank7) of the FPGA device A3PE1500-PQ208. These 16 signals are terminated on the J40 and J41 connectors. The FPGA pins used for LVDS signaling are listed in [Table 7](#), page 13.

The LVDS signals are terminated on J40 and J41 connectors so that a standard patch cable can be used for doing loop-back testing. For schematic representation of connector signal details, see [Figure 16](#), page 35.

The four differential pairs (consisting of eight I/O pins) are terminated, as listed in the following table, using the following color convention on the first RJ45 connector (referred to as CAT 5E Primary for the purpose of differentiation).

**Table 5 • Color Convention on CAT 5E Primary**

Color	Pin	Signal
White/Orange	p1	TX1+
Orange	p2	TX1–
White/Green	p3	RX1+
Blue	p4	TX2–
White/Blue	p5	TX2+
Green	p6	RX1–
White/Brown	p7	RX2+
Brown	p8	RX2–

**Note:** TXn+ refers to positive signal of the transmit side of balanced signal transmission.

**Note:** TXn– refers to negative signal of the transmit side of balanced signal transmission.

**Note:** RXn+ refers to positive signal of the receive side of balanced signal transmission.

**Note:** RXn– refers to negative signal of the receive side of balanced signal transmission.

The four differential pairs (consisting of eight I/O pins) are terminated, as listed in the following table, using the following color convention on the second LVDS connector (referred to as “CAT 5E SECONDARY” for the purpose of differentiation).

**Table 6 • Color Convention on CAT 5E Secondary**

Color	Pin	Signal
White/Orange	p1	RX3+
Orange	p2	RX3–
White/Green	p3	TX3+
Blue	p4	RX4–
White/Blue	p5	RX4+
Green	p6	TX3–
White/Brown	p7	TX4+
Brown	p8	TX4–

**Note:** The colors refer to the colors that will appear on the CAT 5E cable. The pin numbers correspond to the pin numbers of an RJ-45 connector. Note that the CAT-5E PRIMARY connections are labeled for the purposes of what is regarded as standard connections for CAT-5E on Ethernet-type connectors. The connections on the CAT-5E SECONDARY are reversed so as to allow a standard patch cable to check loop-back on these LVDS signals.

A 1-foot CAT5 standard patch cable supplied with the ProASIC3/E Starter Kit can be used for LVDS signals loop-back. Also note that the VCCI and VMV voltages of Bank6 and Bank7 (west side) are

connected to a fixed 2.5 volts, which is required in ProASIC3 (LVDS only available in A3P250 and larger) and ProASIC3E (LVDS available in all devices) for LVDS signaling.

**Table 7 • FPGA – LVDS I/O Pin Details**

FPGA Pin No.	FPGA I/O Pin Name <sup>1</sup>	Signal Name	CAT5E Connector Pin No.
7	GAC2/IO132PDB7V1	TX1+	CAT 5E – PRI – 1
8	IO132NDB7V1	TX1–	CAT 5E – PRI – 2
9	IO130PDB7V1	TX2+	CAT 5E – PRI – 5
10	IO130NDB7V1	TX2–	CAT 5E – PRI – 4
11	IO127PDB7V1	RX1+	CAT 5E – PRI – 3
12	IO127NDB7V1	RX1–	CAT 5E – PRI – 6
13	IO126PDB7V0	RX2+	CAT 5E – PRI – 7
14	IO126NDB7V0	RX2–	CAT 5E – PRI – 8
30	GFA2/IO117PDB6V1	TX3+	CAT 5E – SEC – 3
31	IO117NDB6V1	TX3–	CAT 5E – SEC – 6
37	IO112PDB6V1	TX4+	CAT 5E – SEC – 7
38	IO112NDB6V1	TX4–	CAT 5E – SEC – 8
42	IO106PDB6V0	RX3+	CAT 5E – SEC – 1
43	IO106NDB6V0	RX3–	CAT 5E – SEC – 2
44	GEC1/IO104PDB6V0	RX4+	CAT 5E – SEC – 5
45	GEC0/IO104NDB6V0	RX4–	CAT 5E – SEC – 4

1. Pin names are valid only for the A3PE600-PQ208 part. They are not correct for use with an A3P250.
2. J40: RJ45 connector is referred as CAT 5E PRIMARY connector.
3. J41: RJ45 connector is referred as CAT 5E SECONDARY connector.

For the location of J40 and J41 connectors on the ProASIC3/E Starter Kit board, see [Figure 1](#), page 4.

## 4 Setup and Self Test

---

This section provides information about how to set up and test the ProASIC3/E Starter Kit board.

### 4.1 Software Installation

The ProASIC3/E Starter Kit includes Libero SoC software. For the latest version of Libero SoC software, go to <https://www.microsemi.com/products/fpga-soc/design-resources/design-software/libero-soc#overview>.

For Libero SoC software installation instructions, see the *Libero SoC Quick Start Guide*.

### 4.2 Hardware Installation

FlashPro4 is required to use the ProASIC3/E Starter Kit. For software and hardware installation instructions, see the *FlashPro User Guide*.

### 4.3 Testing the Starter Kit Board

See *Testing the Board*, page 19.

### 4.4 Programming the Test File

To retest the Starter Kit board at any time, use the test program to reprogram the board. Download the ProASIC3/E Starter Kit example design at: <https://www.microsemi.com/products/fpga-soc/design-resources/dev-kits/proasic3/proasic3-starter-kit#documents>.

Using FlashPro software, program the example design on ProASIC3/E device. This design is currently implemented for the A3PE1500 die size. For a device of a different size, it is possible to recompile the design into other device sizes. For information about retargeting the device, see the *Designer User's Guide*.

For instructions on programming the device using FlashPro4, see the *FlashPro User Guide*.

## 5 Description of Test Design

The description of the test design is provided with the Starter Kit. This design contains a data generator block for LEDs, PLL for clock generation, and an OLED display driver block. A block diagram of the design is shown in the following figure.

**Note:** The latest version of the board A3PE-STARTER-KIT-2 REV B does not have OLED display. For more information, see the [CN1418A: Addendum A: Designing without OLED Display on Kits](#).

**Figure 3 • Design Block Diagram**

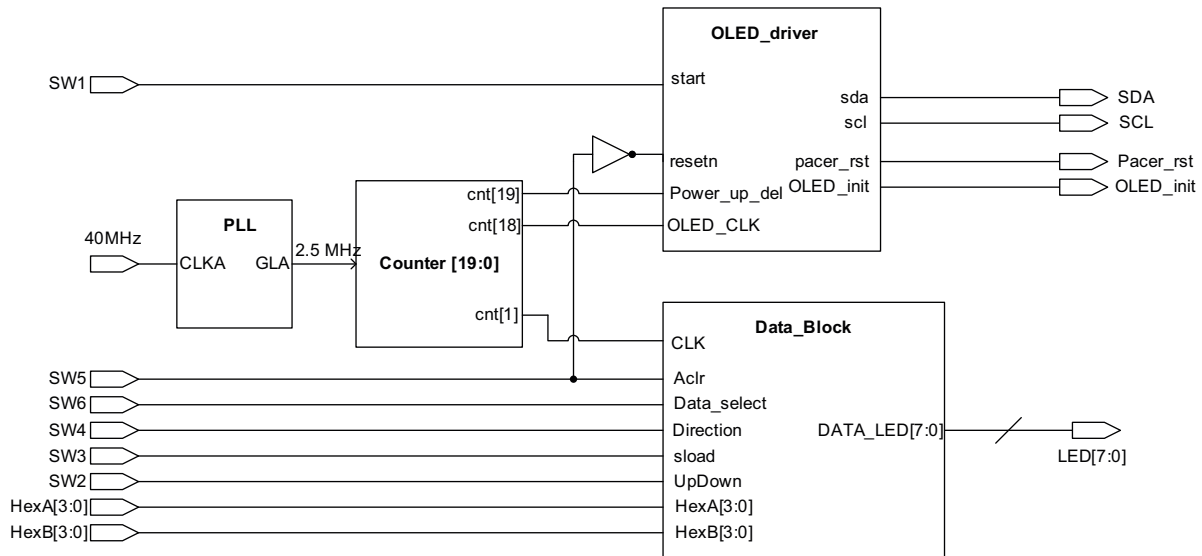

The on-chip PLL takes a 40 MHz oscillator clock as reference input and generates 2.5 MHz clock for the design. The data generator (Data\_Block) generates an eight-bit up-down counter and eight-bit flashing signal. The data generator output is displayed on the ProASIC3/E starter kit board LEDs. By default, an eight-bit flashing signal is displayed on the LEDs. The LEDs flashing direction can be changed by pressing SW4. Switch the data using the SW6 signal. The counter has synchronous load and an asynchronous clear. The counter can be loaded with the hex switches data by pressing SW3. Press and hold SW2 for down counting.

The following figure shows a block diagram of the Data\_Block.

**Figure 4 • Data Block Diagram**

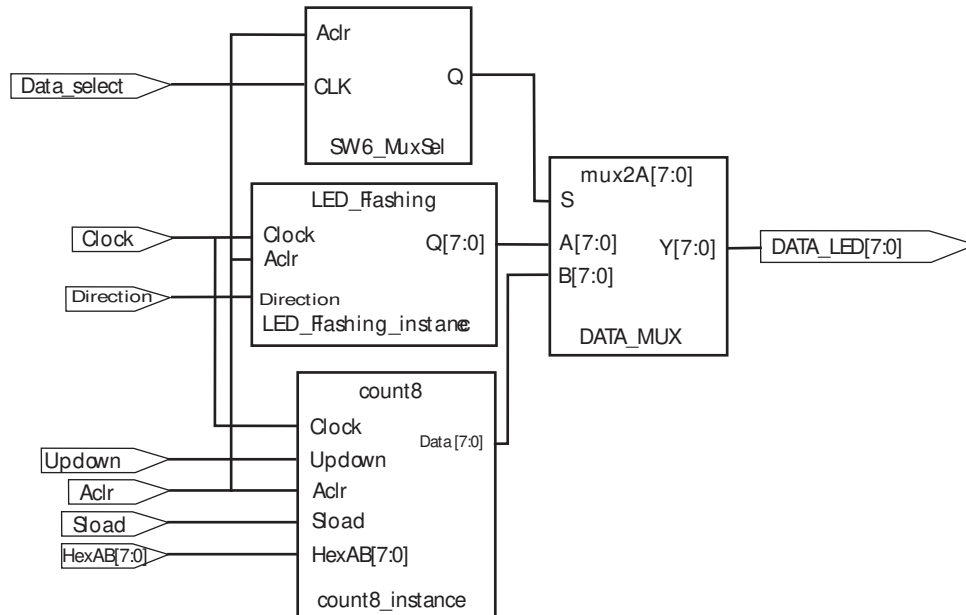

The following table lists the functionality of different switches.

**Table 8 • Switches**

Action	Results
Press SW2	Up-Down control for the 8-bit counter. Press and hold SW2 for down count.
Press SW3	Synchronous load for the 8-bit counter. Press SW3 for loading from the hex switches. Holding the SW3 displays the hex switches value on LEDs.
Press SW4	Direction control for LEDs flashing. While LEDs flashing is selected with SW6, SW4 can be used to change the LEDs flashing direction.
Press SW5	Asynchronous clear for the whole design.
Press SW6	Select for DATA_BLOCK. It allows switching LED output between the counter and flashing data.
Change Hex Switch setting (U13 and U14)	Changes the loaded data for the eight-bit counter.

## 6 LVDS Signal Evaluation

This section explains the test setup and design for the LVDS signal evaluation. It reports the measurements performed on the board, and at the end, makes recommendations to increase the LVDS signal quality in order to meet the performance criteria.

### 6.1 Hardware Test Setup

The test setup uses a ProASIC3 Development Kit containing an A3PE600-PQ208 engineering sample. LVDS loop-back is closed using various lengths of CAT-5E cables (1-, 3-, and 6-foot). The measurements are taken using a 1159A-1 GHz Agilent differential probe.

### 6.2 Design Test Setup

The following figure shows the block diagram of the transmitter section of the test design programmed inside the ProASIC3 FPGA. The design contains two similar channels of data. Channel A is driven by a PLL to achieve high data rates, and Channel B uses an external clock in the event that slow data rates are needed for test or debugging purposes.

Figure 5 • TX Portion of Test Design

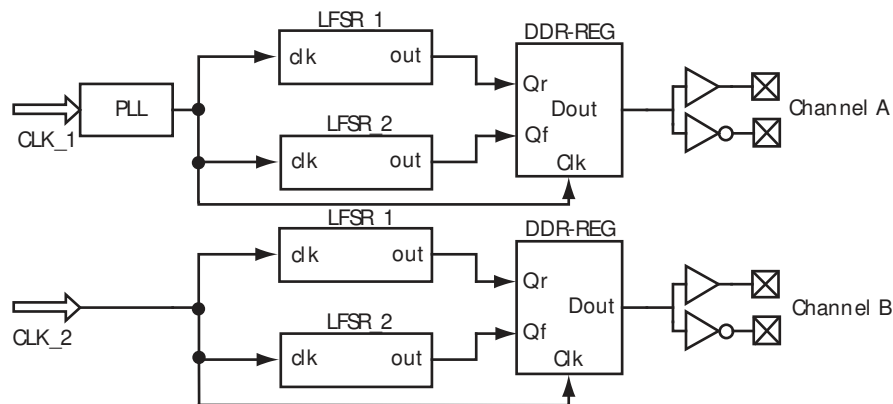

Each channel uses an LFSR to generate a pseudo-random data stream. The data stream is entered in DDR registers to achieve higher data rates from relatively slower clocks (e.g., 300 Mbps data rate from 150 MHz clock). The output of the DDR registers is sent out using the LVDS I/O standard. The output data is looped back and received by the FPGA using LVDS receivers.

### 6.3 Measurement Results

The following figure shows the LVDS signal across the 100 Ohm termination resistor at 300 Mbps. The eye height across the termination is about 275 mV which is well within the LVDS specification.

**Figure 6 • LVDS Signal across RX Termination at 300 Mbps**





## 7 Testing the Board

---

This section defines the test procedure required to be carried out by the Microsemi SoC Products Group designated manufacturer's testing facility on the ProASIC3/E Starter Kit board with silkscreen labeling A3PE-STARTER-KIT-2. This testing is specific to the socketed version of the board. All steps in the following enumerated test procedure should be followed in sequence for testing the board. Deviations in the sequence are explained in the text.

### 7.1 Equipment Required

This section provides the equipments required for testing the board.

#### 7.1.1 Equipment Provided to Testing Facility

Microsemi SoC Products Group provides the following:

- Test procedure document.
- FlashPro v9.1 software or latest on Microsemi website
- FlashPro4 programmer and programming cable for connecting to the A3PE-STARTER-KIT-2.
- Pre-programmed A3PE1500-PQ208 silicon. Ten devices will be provided for ten boards. The initial silicon will not be labeled as having been programmed. (this is just for the testing associated with the first manufacturing build.) Additional devices will be provided for testing further boards and this change will be detailed in an update to the procedure.
- Power supply (+9 V, 2 A CUI) for the ProASIC3/E Starter Kit board plus a mains cable for the power supply.

#### 7.1.2 Testing Facility Equipment

The manufacturer's testing facility will provide the following equipment for testing of the board: Digital Multimeter to measure voltages on the circuit board at the known test points.

### 7.2 Test Procedure for the A3PE-STARTER-KIT-2

In this section, full test procedure for the boards is outlined. This procedure applies to socketed boards. For boards fitted with directly soldered parts, the procedure is the same except for fitting of the FPGA. In such cases, adjust the procedure accordingly and ignore references to fitting parts to sockets.

#### 7.2.1 Initial Power-On Procedure

This part of the procedure may be carried out independently and ahead of the other parts of the test procedure. Boards passing this procedure may be transferred to a passing set of boards.

The following steps describe the procedure to perform the initial power-on.

1. Record the time of the test and the board serial number (written by the bar code on the back of the board) into a test log.
2. Plug the +9 V power supply into the wall.
3. Take an A3PE-STARTER-KIT-2 that has an empty socket. Ensure the switch SW11 is in the OFF position, (the switch should be moved to the left). This corresponds with the labeling of the silkscreen on the board.
4. Connect +9 V DC output of the CUI power supply to the J18 connector on the board. You should observe the red LED at the top right of the board; LED D19 should light, indicating +9 V DC has been applied to the board.
5. Move the SW11 switch to the ON position—to the right. Observe that LEDs, D13, D9, D10, D11, and D17 light up green on the board. All LEDs are on the top edge of the board (same edge as red D19 power connector LED, which should remain lit).
6. Using a DVM, measure DC voltages using TP11 as ground:
7. TP6 and TP7 should be 3.3 V (values  $\pm 0.2$  V are acceptable). Values outside this range are a failure.
8. TP15 should be 1.5 V (values  $\pm 0.1$  V are acceptable).
9. TP8 should be 1.8 V (values  $\pm 0.1$  V are acceptable).

10. TP10 should be 2.5 V (values  $\pm 0.2$  V are acceptable).
11. TP47 should be 5.0 V (values  $\pm 0.2$  V are acceptable).
12. J14C pin 106 should be 3.3 V (values  $\pm 0.2$  V are acceptable). Note that jumper JP48 must be in place for this measurement, otherwise zero will be recorded.
13. That completes the initial power-on check. The board should now be switched off by moving SW11 to the OFF position (to the left).

## 7.2.2 Testing Board Functionality with A3PE1500-PQ208 Silicon

The following steps describe the functionality to test the board.

1. Record the time of the test and the board serial number (written by the bar code on the back of the board) into a test log.
2. Make sure the switch SW11 is in the OFF position (i.e., to the left.)
3. Apply power to the board by attaching the +9 V DC supply to J18. Only the red LED should be illuminated.
4. Undo the four screws holding the socket of U8 in place. Remove the lid of the socket.
5. Place a pre-programmed A3PE1500-PQ208 part into the socket using the appropriate vacuum pen while observing anti-static precautions. Make sure that pin 1 of the FPGA is oriented correctly. The Microsemi SoC Products Group logo on the part should match the orientation of the Microsemi SoC Products Group logo on the board just above the A3PE-STARTER-KIT-2 part number. Take great care to make sure all pins are in correct alignment so that the FPGA is on a level plane parallel to the board.
6. Carefully replace the socket cover and screw down all four corners to appropriate tightness. It is recommended to do opposite corners first so as to lessen rotational torque on the part.
7. Supply power to on-chip PLL by connecting respective supply pin to analog supply rails. Place jumper on JP50 to power the west side PLL, known as PLF. The ground pin of the west side PLL (VCOMPLF) is already connected to ground.
8. Switch on SW11 to the ON position (slide it to the right).
9. Validate that all 5 LEDs at the top of the board including the red one turn on. D17, D11, D10, D9, D13, and D19.
10. Validate that the 8 LEDs: D8, D7, ..., and D2, D1 all pulsate in either a counting pattern or a flashing towards left pattern.
11. If no LEDs are visible, stop and switch off SW11. Rotate SW8 and SW9 clockwise to the 3.3 V selection. This is best described with the thicker arrow bar pointing upward. Switch the board back on. The LEDs should be visible. If very dim, stop, switch off the board and rotate the switches one quarter turn clockwise before switching board back on. Continue if the LEDs are glowing. If unable to get a display on the LEDs, the board must be tagged as bad.
12. If it is a bad board, carefully remove the A3PE1500 silicon from the socket and set it aside in an electrostatic-safe area. Using another piece of pre-programmed silicon, repeat steps 4 to 8 above.
13. If still no response, mark the board as defective and re-use the silicon for other testing.
14. If there is a good response, then place the previous silicon in a "bad" tray to prevent it from being retested.
15. Validate the change in direction of LEDs flashing by pressing SW4 on the bottom side of the board.
16. Validate that the patterns can be switched by pressing SW6 (Global pulse) on the left side of board. When the switch is pressed, the LED D15 should momentarily light. The pattern on the 8 LEDs D8 through D1 will change.
17. Press and hold SW2 to change the counting direction. Validate the change in counting pattern on LEDs.
18. Press and hold SW3 to validate the hex switches values displayed on LEDs.
19. Connect a FlashPro4 programmer to a PC USB port and observe the power light illuminating. Ensure that the FlashPro 9.1 or latest version is installed on the PC being used.
20. Connect the programming cable of the FlashPro4 programmer to the J1 shrouded and keyed header labeled FP. The red line labeling pin 1 should be close to pin 1 on the header – no other orientation is possible.  
On the PC, run the FlashPro 9.1 or latest version and connect to the programmer. Select ProA-SIC3E as the device family. Once the software has shown a connection, select Analyze Chain from the File menu.

If an error message of incorrect VJTAG is reported, then remove the jumper placed at J5 and place it instead at J12 across pins 11 and 12. It may safely be left there. Repeat the Analyze Chain command.

If a message appears indicating that an A3PE1500 part (depending on the device fitted to the board) has been detected, then the board has passed this test. Leave the silicon in place in the socket and move to the next step.

If a message of 11 or some other numeric indication appears, then record the message in a test log and fail the board. Remove the silicon from the socket and place it in the safe silicon holding area.

21. This concludes the testing of the board. Switch SW11 to the OFF position and remove the power connector from J18.

## 8 Appendix: PQ208 Package Connections

---

### 8.1 I/O Naming Conventions

Due to the comprehensive and flexible nature of ProASIC3/E device user I/Os, a naming scheme is used to show the details of the I/O. The name identifies to which I/O bank it belongs, as well as the pairing and pin polarity for differential I/Os.

$$\text{IO Nomenclature} = \frac{\text{Gmn}}{\text{IOuxwBy}}$$

Where,

m = Global pin location associated with each CCC on the device: A (northwest corner), B (northeast corner), C (east middle), D (southeast corner), E (southwest corner), and F (west middle)

n = Global input MUX and pin number of the associated Global location m, either A0, A1, A2, vB0, B1, B2, C0, C1, or C2

u = I/O pair number in the bank, starting at 00 from the northwest I/O bank in a clockwise direction

x = P (Positive) or N (Negative) for differential pairs, or S (Single-Ended) for the I/O that support single-ended and voltage-referenced I/O standards only

w = D (Differential Pair) or P (Pair) or S (Single-Ended). D (Differential Pair) if both members of the pair are bonded out to adjacent pins or are separated only by one GND or NC pin; P (Pair) if both members of the pair are bonded out but do not meet the adjacency requirement; or S (Single-Ended) if the I/O pair is not bonded out. For Differential (D) pairs, adjacency for ball grid packages means only vertical or horizontal. Diagonal adjacency does not meet the requirements for a true differential pair.

B = Bank

y = Bank number [0.3] for ProASIC3 and [0.7] for ProASIC3E. Bank number starting at 0 from the northwest I/O bank in a clockwise direction

Figure 7, page 23 and Table 9, page 24 are extracted from the ProASIC3E datasheet and provide package connections for the A3PE1500 device. Pinouts for other devices in the PQ208 family can be found at:

[DS0097: ProASIC3 Flash Family FPGAs Datasheet](#)

[DS0098: ProASIC3E Flash Family FPGAs Datasheet](#)

The website should always be referenced for access to the most recent datasheet.

## 8.2 208-Pin PQFP

The following figure shows the top view of the package.

Figure 7 • 208-Pin PQFP

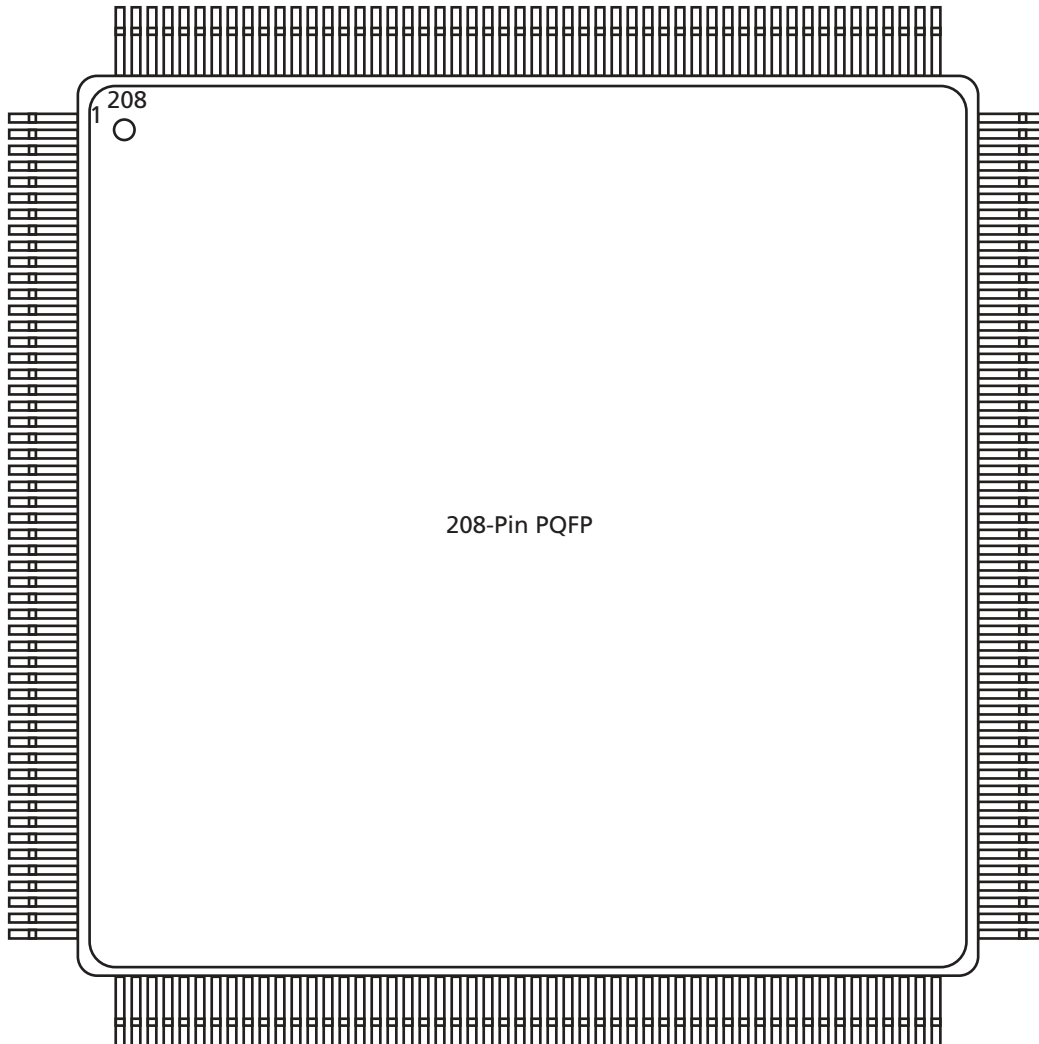

The following table lists the device connections for 208-Pin PQFP.

**Table 9 • Device Connections for 208-Pin PQFP**

208-Pin PQFP		208-Pin PQFP		208-Pin PQFP	
Pin Number	A3PE1500 Function	Pin Number	A3PE1500 Function	Pin Number	A3PE1500 Function
1	GND	36	VCC	71	VCC
2	GNDQ	37	IO184PDB6V2	72	VCCIB5
3	VMV7	38	IO184NDB6V2	73	IO145NDB5V1
4	GAB2/IO220PSB7V3	39	IO180PSB6V1	74	IO145PDB5V1
5	GAA2/IO221PDB7V3	40	VCCIB6	75	IO143NDB5V1
6	IO221NDB7V3	41	GND	76	IO143PDB5V1
7	GAC2/IO219PDB7V3	42	IO176PDB6V1	77	IO137NDB5V0
8	IO219NDB7V3	43	IO176NDB6V1	78	IO137PDB5V0
9	IO215PDB7V3	44	GEC1/IO169PDB6V0	79	IO135NDB5V0
10	IO215NDB7V3	45	GEC0/IO169NDB6V0	80	IO135PDB5V0
11	IO212PDB7V2	46	GEB1/IO168PPB6V0	81	GND
12	IO212NDB7V2	47	GEA1/IO167PPB6V0	82	IO131NDB4V2
13	IO208PDB7V2	48	GEB0/IO168NPB6V0	83	IO131PDB4V2
14	IO208NDB7V2	49	GEA0/IO167NPB6V0	84	IO129NDB4V2
15	IO204PSB7V1	50	VMV6	85	IO129PDB4V2
16	VCC	51	GNDQ	86	IO127NDB4V2
17	GND	52	GND	87	IO127PDB4V2
18	VCCIB7	53	VMV5	88	VCC
19	IO200PDB7V1	54	GNDQ	89	VCCIB4
20	IO200NDB7V1	55	IO166NDB5V3	90	IO121NDB4V1
21	IO196PSB7V0	56	GEA2/IO166PDB5V3	91	IO121PDB4V1
22	GFC1/IO192PSB7V0	57	IO165NDB5V3	92	IO119NDB4V1
23	GFB1/IO191PDB7V0	58	GEB2/IO165PDB5V3	93	IO119PDB4V1
24	GFB0/IO191NDB7V0	59	IO164NDB5V3	94	IO113NDB4V0
25	VCOMPLF	60	GEC2/IO164PDB5V3	95	GDC2/IO113PDB4V0
26	GFA0/IO190NPB6V2	61	IO163PSB5V3	96	IO112NDB4V0
27	VCCPLF	62	VCCIB5	97	GND
28	GFA1/IO190PPB6V2	63	IO161PSB5V3	98	GDB2/IO112PDB4V0
29	GND	64	IO157NDB5V2	99	GDA2/IO111PSB4V0
30	GFA2/IO189PDB6V2	65	GND	100	GNDQ
31	IO189NDB6V2	66	IO157PDB5V2	101	TCK
32	GFB2/IO188PPB6V2	67	IO153NDB5V2	102	TDI
33	GFC2/IO187PPB6V2	68	IO153PDB5V2	103	TMS
34	IO188NPB6V2	69	IO149NDB5V1	104	VMV4
35	IO187NPB6V2	70	IO149PDB5V1	105	GND

**Table 9 • Device Connections for 208-Pin PQFP**

208-Pin PQFP		208-Pin PQFP		208-Pin PQFP	
Pin Number	A3PE1500 Function	Pin Number	A3PE1500 Function	Pin Number	A3PE1500 Function
106	VPUMP	141	GND	175	IO35PDB1V0
107	GNDQ	142	VCC	176	IO35NDB1V0
108	TDO	143	IO73NDB2V2	177	IO31PDB0V3
109	TRST	144	IO73PDB2V2	178	GND
110	VJTAG	145	IO71NDB2V2	179	IO31NDB0V3
111	VMV3	146	IO71PDB2V2	180	IO29PDB0V3
112	GDA0/IO110NPB3V2	147	IO67NDB2V1	181	IO29NDB0V3
113	GDB0/IO109NPB3V2	148	IO67PDB2V1	182	IO27PDB0V3
114	GDA1/IO110PPB3V2	149	IO65NDB2V1	183	IO27NDB0V3
115	GDB1/IO109PPB3V2	150	IO65PDB2V1	184	IO23PDB0V2
116	GDC0/IO108NDB3V2	151	GBC2/IO60PSB2V0	185	IO23NDB0V2
117	GDC1/IO108PDB3V2	152	GBA2/IO58PSB2V0	186	VCCIB0
118	IO105NDB3V2	153	GBB2/IO59PSB2V0	187	VCC
119	IO105PDB3V2	154	VMV2	188	IO18PDB0V2
120	IO101NDB3V1	155	GNDQ	189	IO18NDB0V2
121	IO101PDB3V1	156	GND	190	IO15PDB0V1
122	GND	157	VMV1	191	IO15NDB0V1
123	VCCIB3	158	GNDQ	192	IO12PSB0V1
124	GCC2/IO90PSB3V0	159	GBA1/IO57PDB1V3	193	IO11PDB0V1
125	GCB2/IO89PSB3V0	160	GBA0/IO57NDB1V3	194	IO11NDB0V1
126	NC	161	GBB1/IO56PDB1V3	195	GND
127	IO88NDB3V0	162	GND	196	IO08PDB0V1
128	GCA2/IO88PDB3V0	163	GBB0/IO56NDB1V3	197	IO08NDB0V1
129	GCA1/IO87PPB3V0	164	GBC1/IO55PDB1V3	198	IO05PDB0V0
130	GND	165	GBC0/IO55NDB1V3	199	IO05NDB0V0
131	VCCPLC	166	IO51PDB1V2	200	VCCIB0
132	GCA0/IO87NPB3V0	167	IO51NDB1V2	201	GAC1/IO02PDB0V0
133	VCOMPLC	168	IO47PDB1V1	202	GAC0/IO02NDB0V0
134	GCB0/IO86NDB2V3	169	IO47NDB1V1	203	GAB1/IO01PDB0V0
135	GCB1/IO86PDB2V3	170	VCCIB1	204	GAB0/IO01NDB0V0
136	GCC1/IO85PSB2V3	171	VCC	205	GAA1/IO00PDB0V0
137	IO83NDB2V3	172	IO43PSB1V1	206	GAA0/IO00NDB0V0
138	IO83PDB2V3	173	IO41PDB1V1	207	GNDQ
139	IO81PSB2V3	174	IO41NDB1V1	208	VMV0
140	VCCIB2				

## 9 Appendix: Board Schematics

---

This section provides illustrations of the ProASIC3/E Starter Kit board.

**Note:** The following figures are in low resolution. If you would like to see the figures in high resolution, refer to the ProASIC3/E Starter Kit board Schematics, available at:  
[www.microsemi.com/soc/products/hardware/devkits\\_boards/proasic3\\_starter.aspx#docs](http://www.microsemi.com/soc/products/hardware/devkits_boards/proasic3_starter.aspx#docs).



## 9.1 Top-Level View

The following figures illustrates a top-level and a bottom-level view of the ProASIC3/E Starter Kit board.

Figure 8 • Top-Level View of ProASIC3/E Starter Kit Board

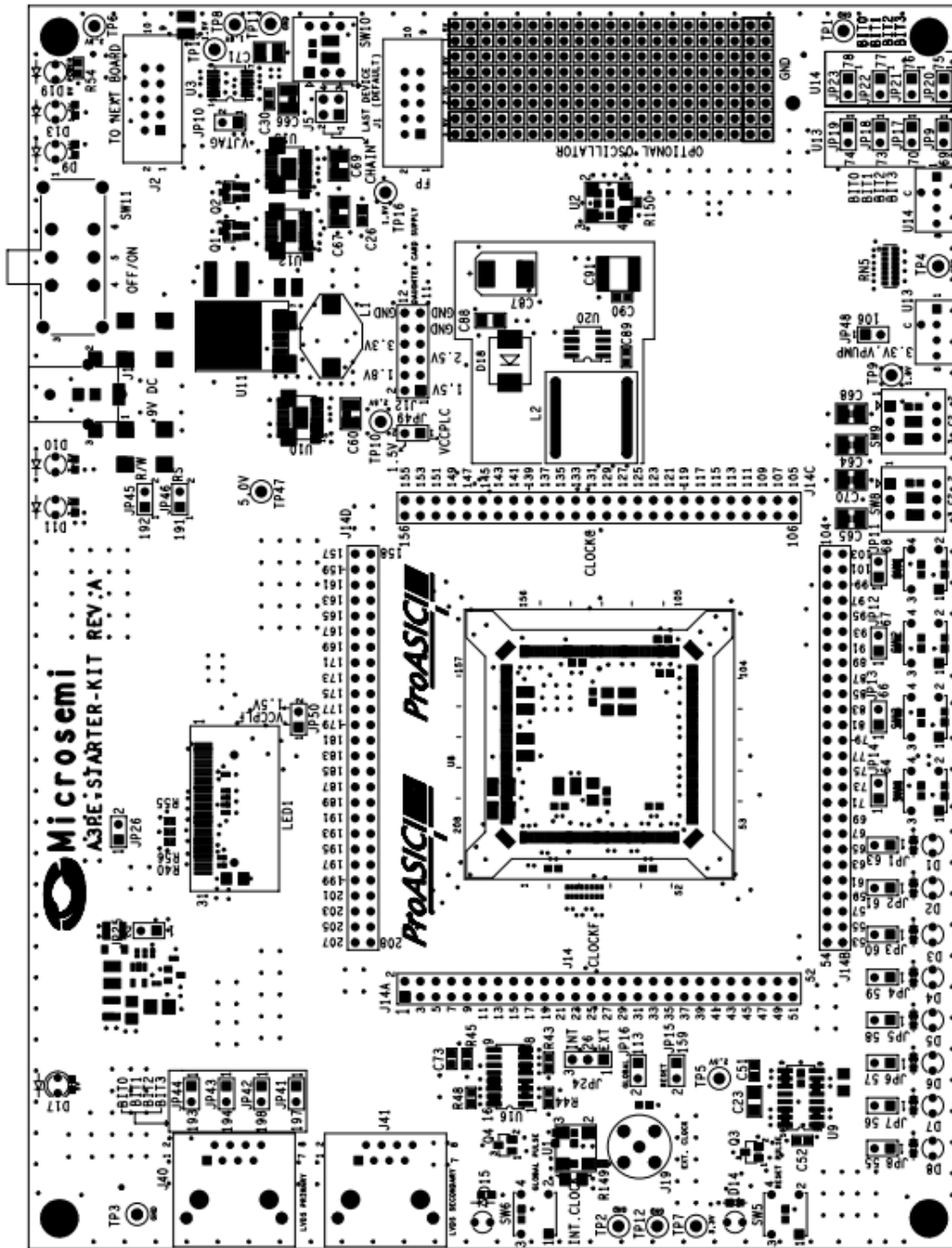
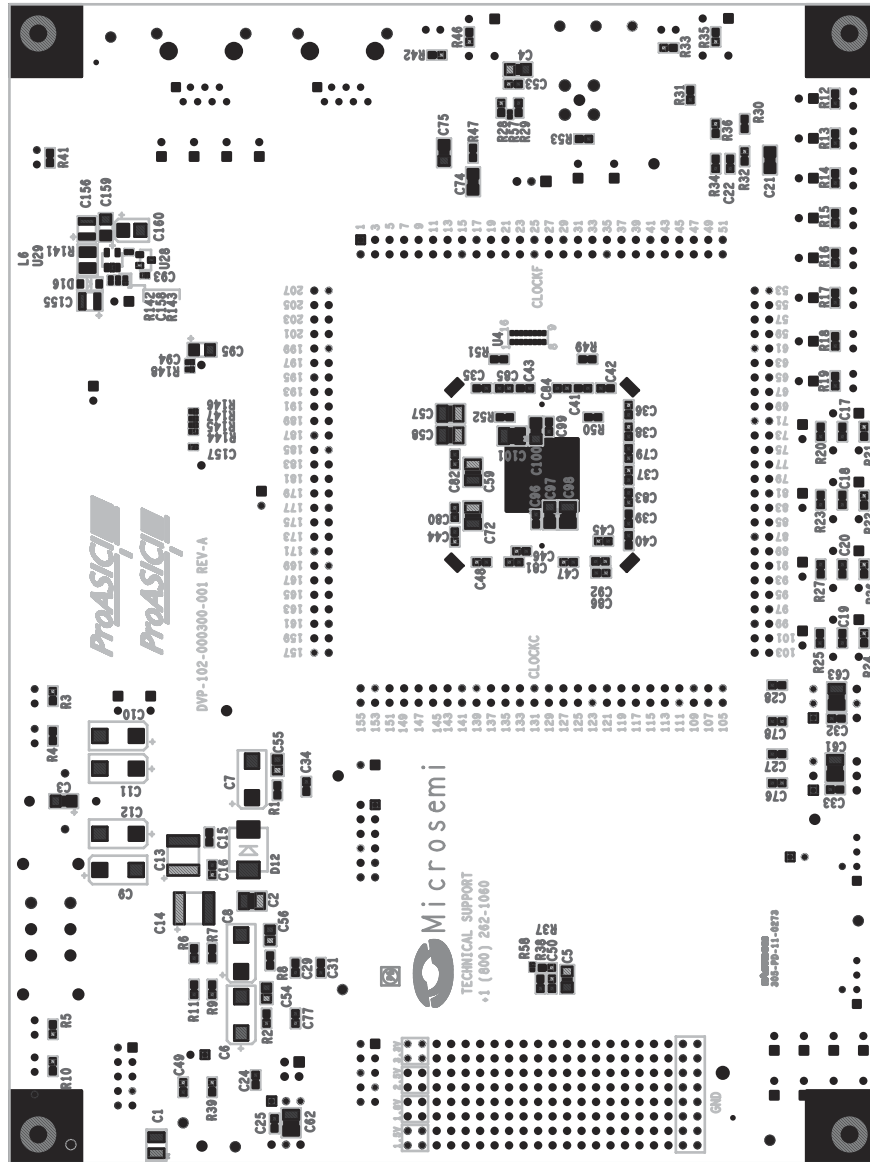

Figure 9 • Bottom-Level View of ProASIC3/E Starter Kit Board



## 9.2 ProASIC3/E Starter Kit Board Schematics

The following are the schematics of the ProASIC3/E Starter Kit board.

Figure 10 • Bottom-Level View of ProASIC3/E Starter Kit Board

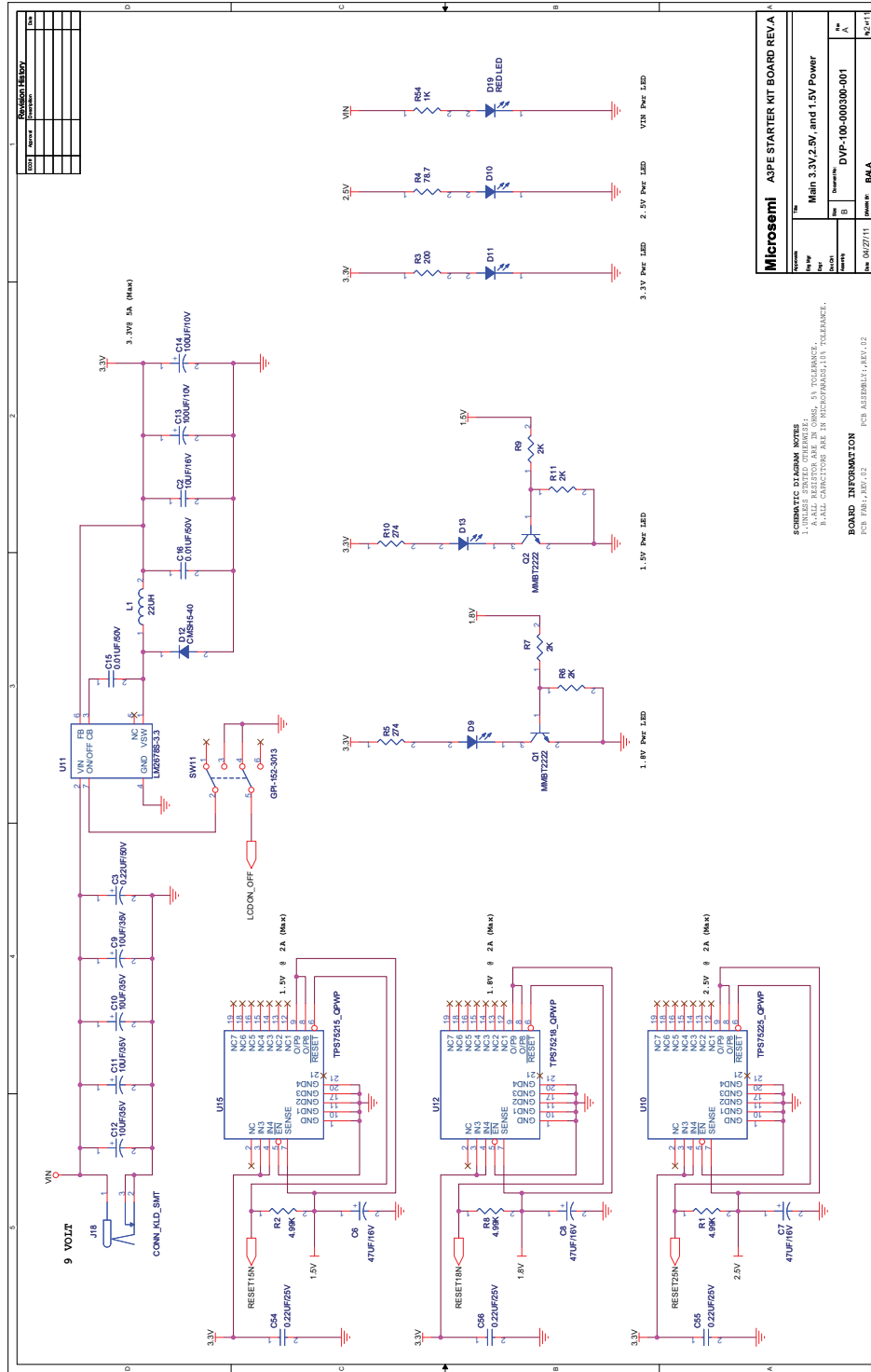
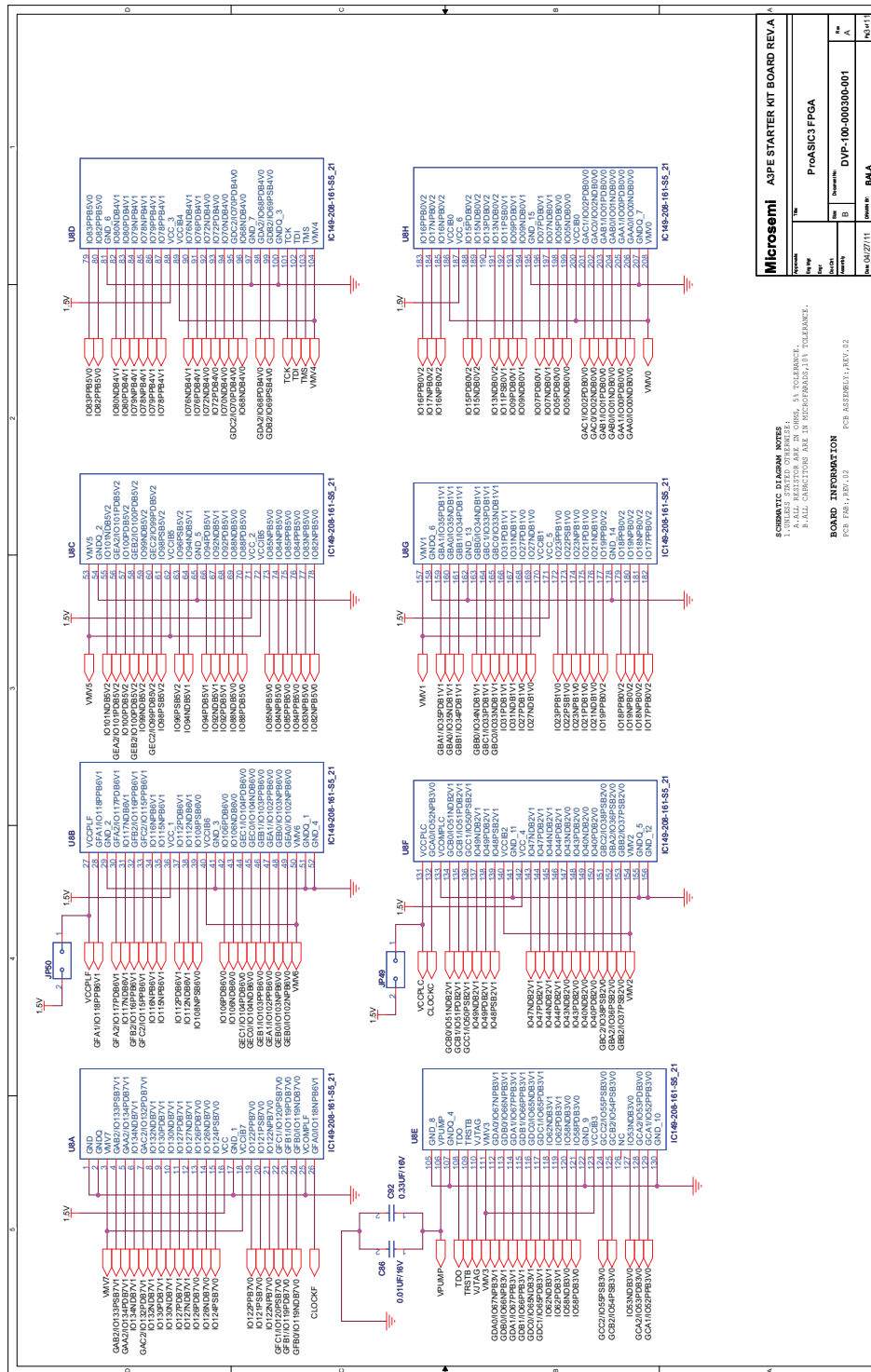

Figure 11 • ProASIC3 FPGA



Microsemi ASPE STARTER KIT BOARD REV.A			
Version	Date	By	For
1.0	01/27/11	James B. Bala	ProASIC3 FPGA
Part Number		DVP-100-000300-001	Rev. A
Doc. No.		DA-100-000300-001	Rev. A
Date		01/27/11	Rev. A
Author		James B. Bala	Rev. A

**SCHEMATIC DRAWING NOTES**  
 1. ALL RESISTORS ARE IN OHMS, 5% TOLERANCE.  
 2. ALL CAPACITORS ARE IN MICROFARADS, 10% TOLERANCE.

**BOARD INFORMATION**  
 PCB FILE: PBA\_001.CAD  
 PCB ASSEMBLY: REV.02

Figure 12 • Push-Button and Hex Switches

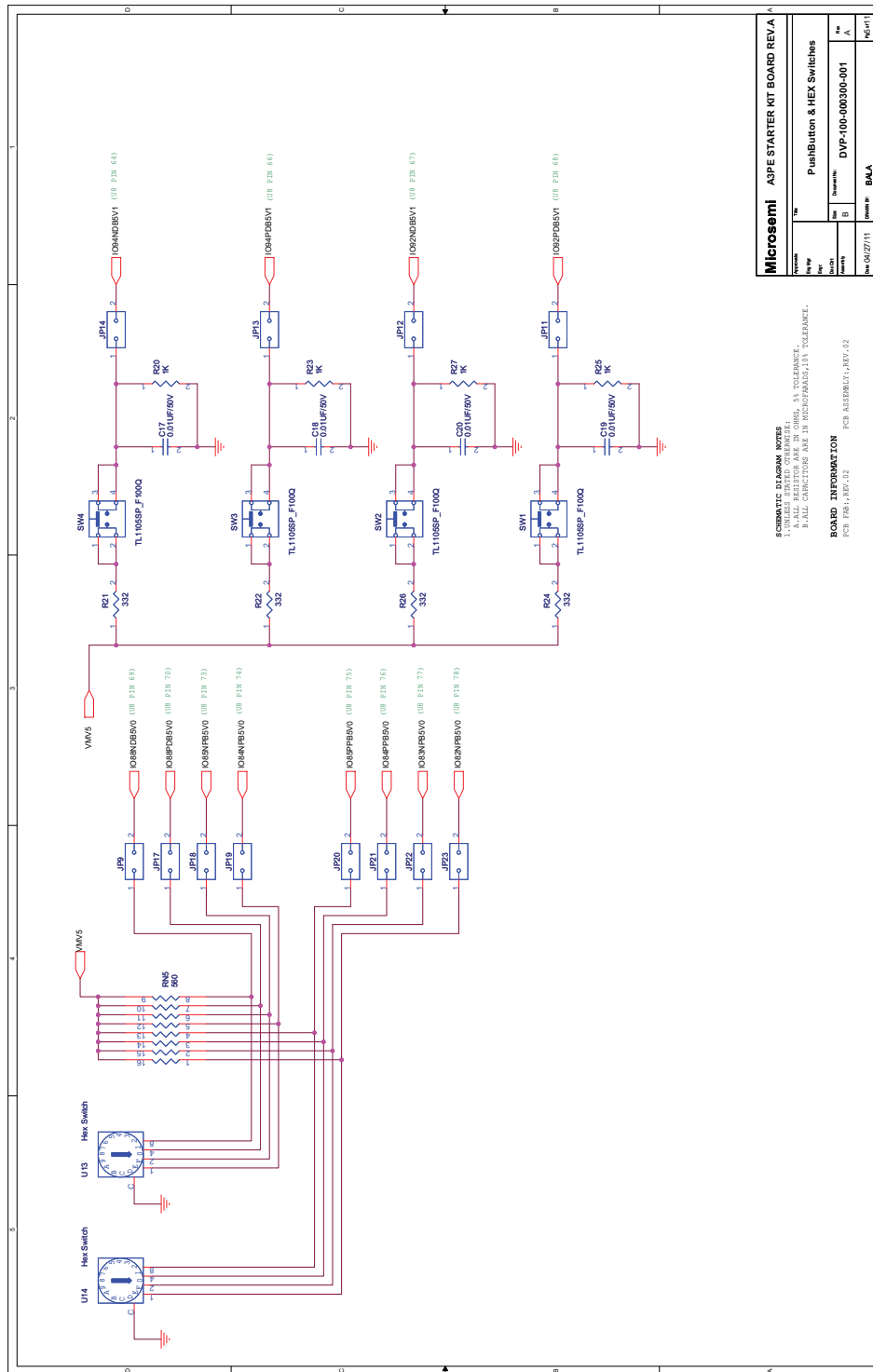

Figure 13 • FPGA Headers and Expansion Bus

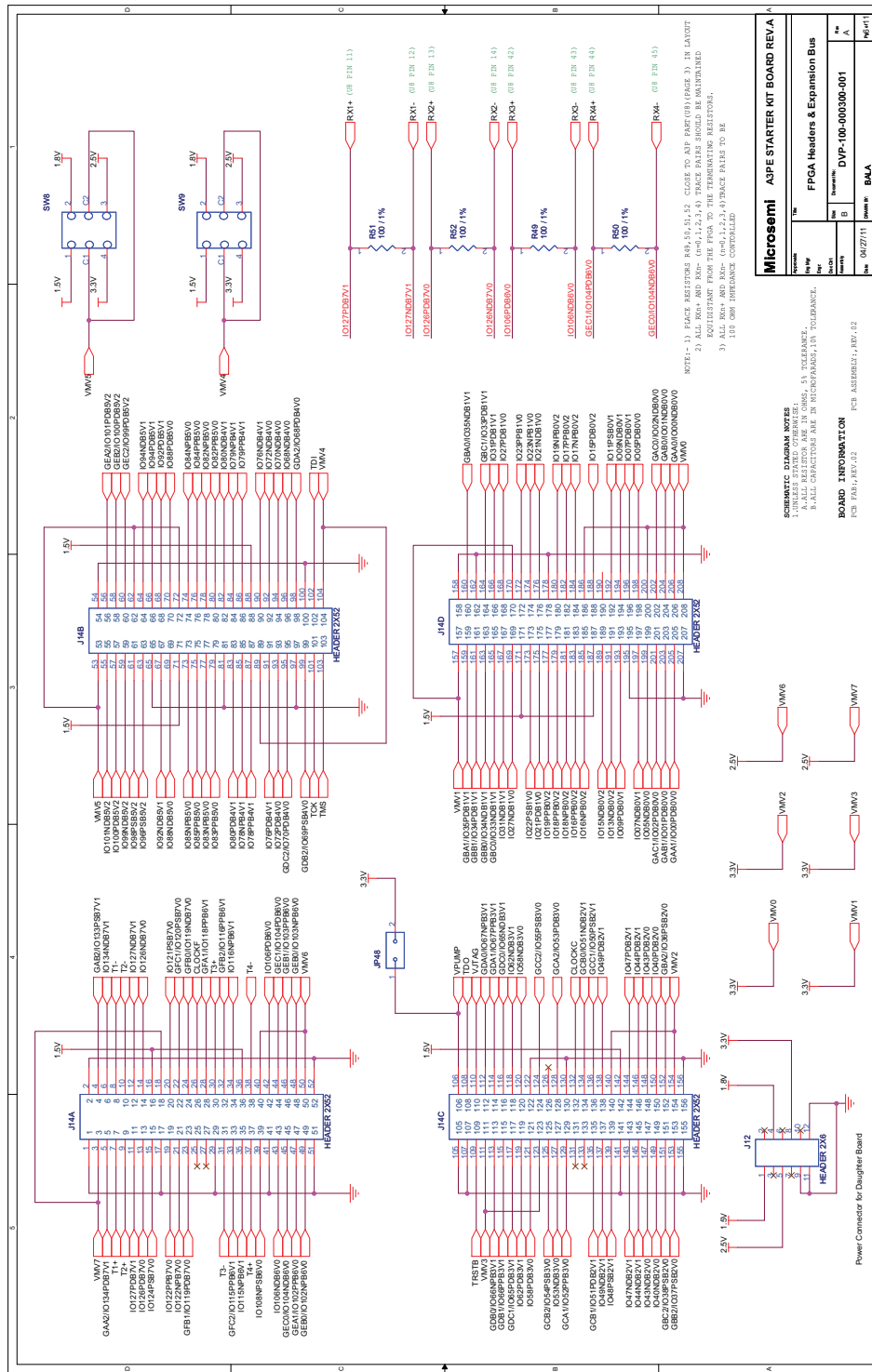

Figure 14 • Clocks Oscillators and Reset

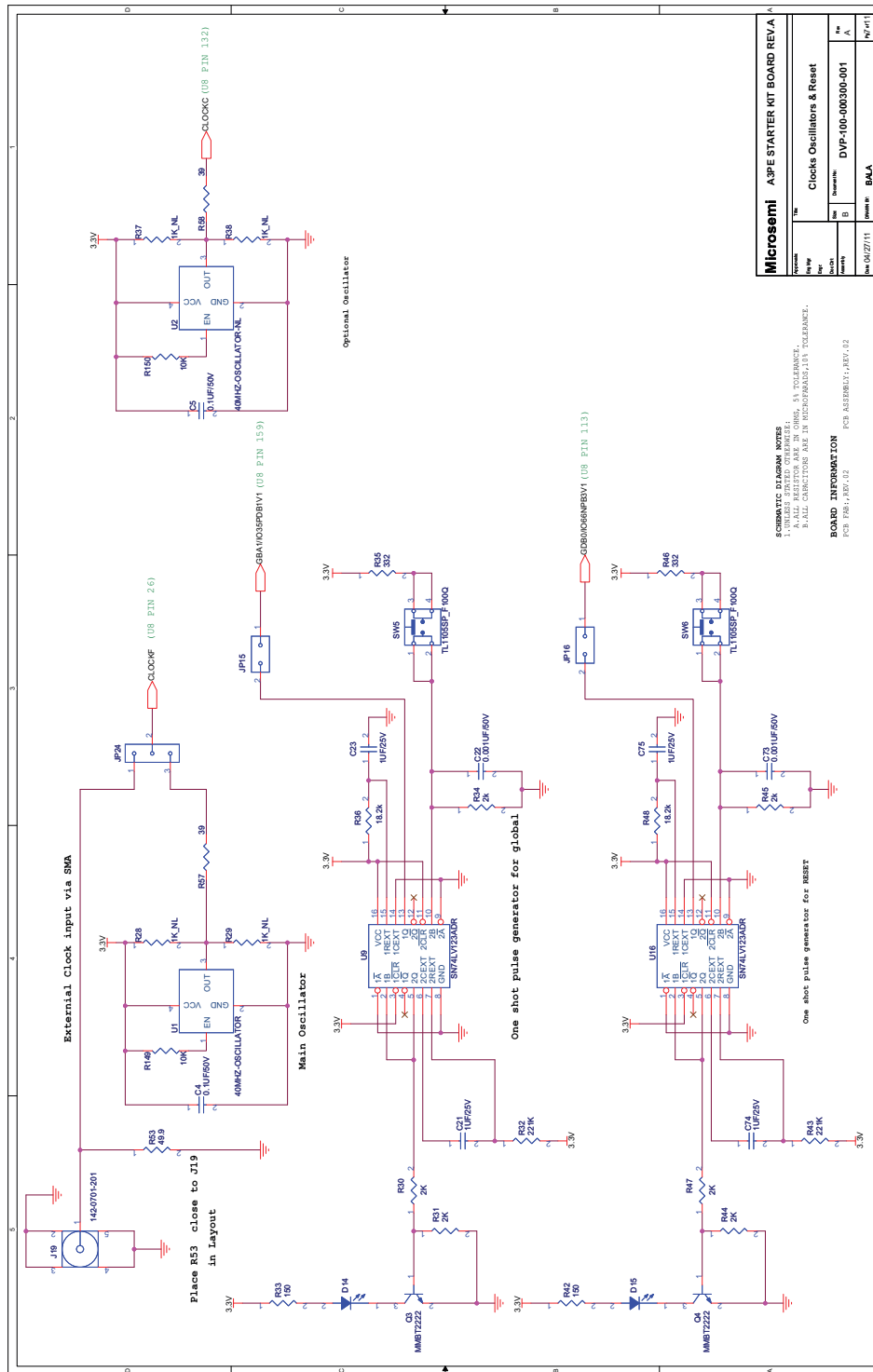

Figure 15 • Decoupling Caps, Test Points

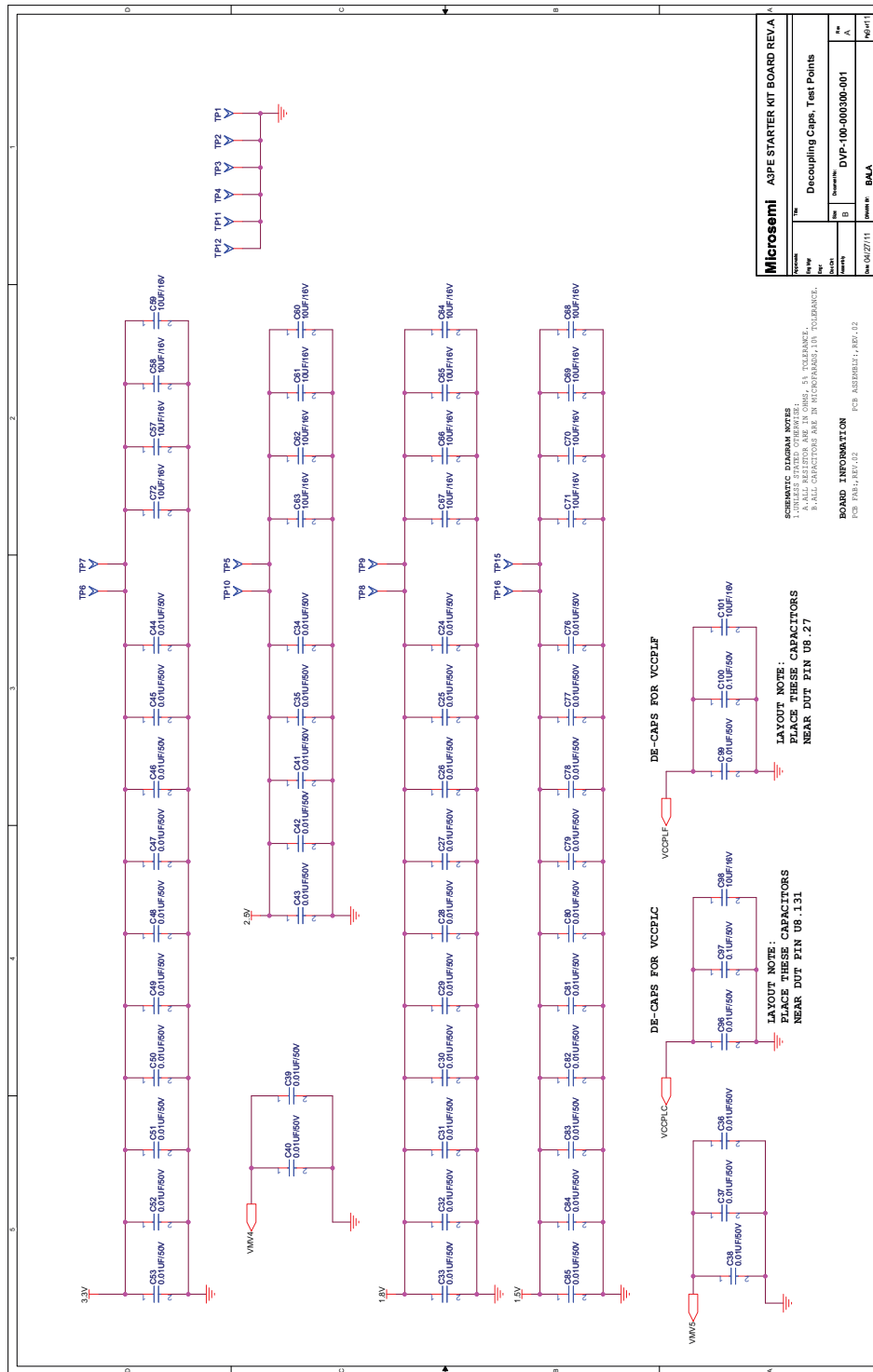



Figure 16 • LVDS Signal Routing Via CAT-5E Connectors

