

SHELL, STEEL, PER QQ-S-698 BRIGHT-TIN PLATED PER MIL-T-10727

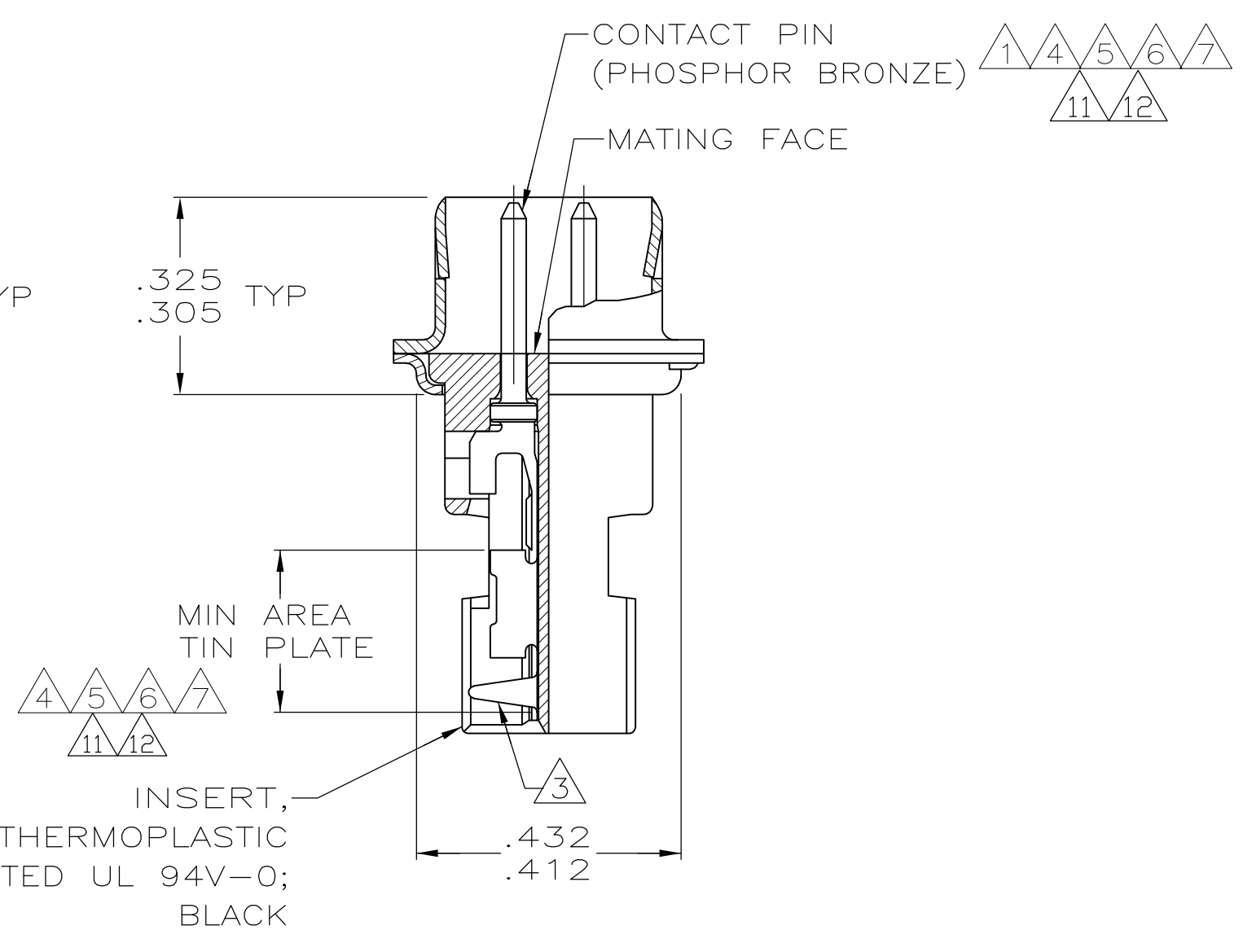
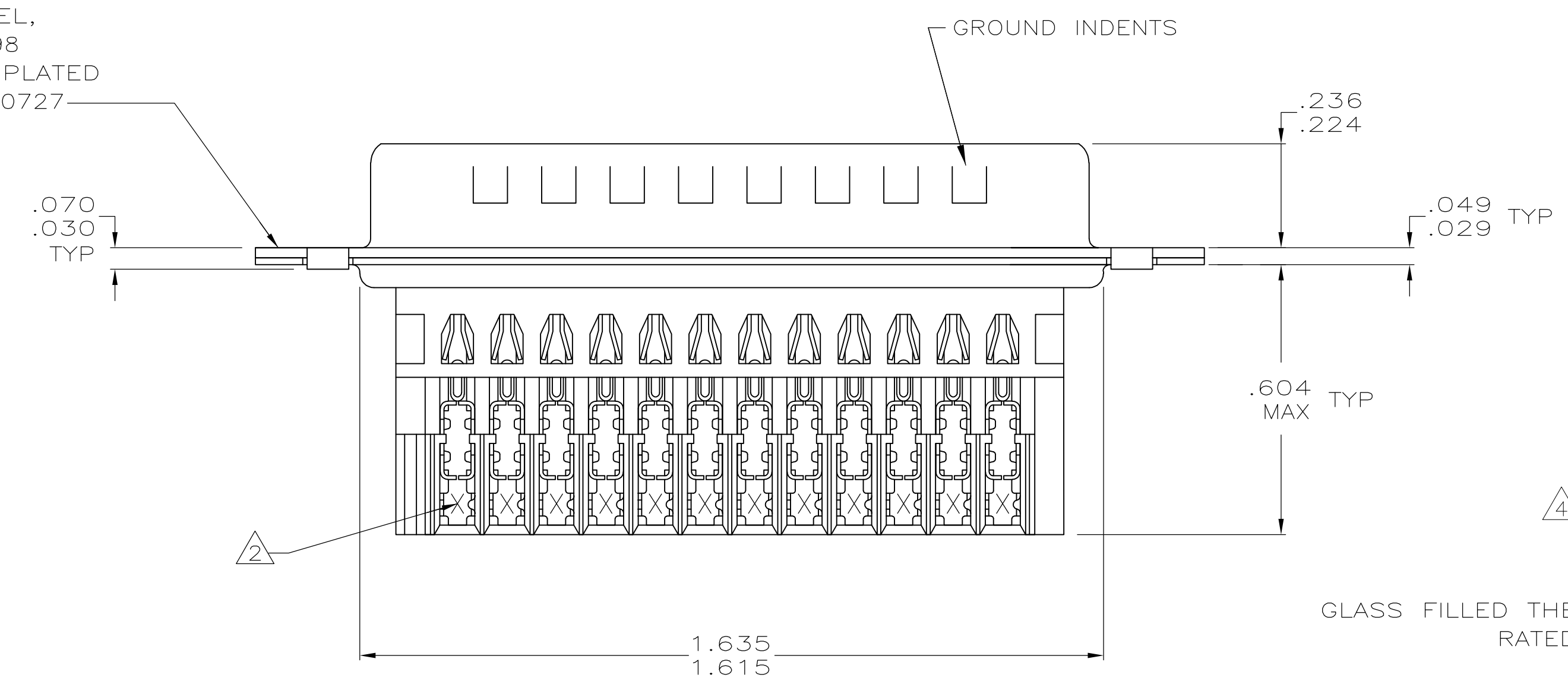

- 1 HOUSING FULLY LOADED WITH CONTACTS.
- 2 NUMBER ON CONTACT INDICATES WIRE RANGE.
- 3 CONTACT INSULATION RANGE: .060 MAXIMUM O.D.
- 4 CONTACTS GOLD PLATED FOR A LENGTH OF .150 MIN FROM MATING END, .000030 MIN GOLD IN MATED AREA, .000100-.000200 BRIGHT TIN OR BRIGHT TIN-LEAD IN AREA SHOWN, ALL OVER .000050 MIN NICKEL UNDERPLATE ON ENTIRE CONTACT.
OR
CONTACTS GOLD PLATED FOR A LENGTH OF .150 MIN FROM MATING END, GOLD FLASH OVER .000030 MIN PALLADIUM-NICKEL IN MATED AREA, .000100-.000200 BRIGHT TIN OR BRIGHT TIN-LEAD IN AREA SHOWN, ALL OVER .000050 MIN NICKEL UNDERPLATE ON ENTIRE CONTACT.
- 5 CONTACTS PLATED GOLD FLASH FOR A LENGTH OF .150 MIN FROM MATING END, .000100-.000200 BRIGHT TIN OR BRIGHT TIN-LEAD IN AREA SHOWN, ALL OVER .000030 MIN NICKEL UNDERPLATE ON ENTIRE CONTACT.
- 6 .000020 GOLD ON MATING END FOR .150 MIN LENGTH. .000100-.000200 BRIGHT TIN OR BRIGHT TIN-LEAD IN AREA SHOWN. .000050 NICKEL UNDERPLATE ON ENTIRE CONTACT.
- 7 GOLD PLATED FOR LENGTH OF .150 MIN FROM MATING END, .000050 MIN GOLD IN MATED AREA. .000100-.000200 BRIGHT TIN OR BRIGHT TIN-LEAD IN AREA SHOWN. .000050 NICKEL UNDERPLATE ON ENTIRE CONTACT.
- 8 SPECIAL DATE CODE IN THIS APPROXIMATE AREA. A; MM = MONTH; Y = LAST DIGIT OF YEAR.
- 9 OBSOLETE PART NUMBER.
- 10 SUPERSEDED BY 745496-5.
- 11 CONTACTS GOLD PLATED FOR A LENGTH OF .150 MIN FROM MATING END, .000030 MIN GOLD IN MATED AREA, .000100-.000200 MATTE TIN IN AREA SHOWN, ALL OVER .000050 MIN NICKEL UNDERPLATE ON ENTIRE CONTACT.
OR
CONTACTS GOLD PLATED FOR A LENGTH OF .150 MIN FROM MATING END, GOLD FLASH OVER PALLADIUM-NICKEL, .000030 MIN TOTAL IN MATED AREA, .000100-.000200 MATTE TIN IN AREA SHOWN, ALL OVER .000050 MIN NICKEL UNDERPLATE ON ENTIRE CONTACT.
- 12 CONTACTS PLATED GOLD FLASH FOR A LENGTH OF .150 MIN FROM MATING END, .000100-.000200 MATTE TIN IN AREA SHOWN, ALL OVER .000030 MIN NICKEL UNDERPLATE ON ENTIRE CONTACT.

STANDARD	FINISH	FINISH	AWG	WIRE RANGE	PART NUMBER
.125 .115	11	3	#20-22	2-745496-0	
.125 .115	11	1	#26-30	1-745496-9	
.125 .115	12	2	#22-26	1-745496-8	
.125 .115	11	2	#22-26	1-745496-7	
SMALL PACK .125 .115	5	2	#22-26	10 1-745496-6	
.125 .115	7	2	#22-26	9 1-745496-4	
.125 .115	6	2	#22-26	9 1-745496-3	
.156 .146	5	3	#20-22	9 1-745496-2	
.156 .146	4	2	#22-26	9 1-745496-1	
		1	#26-30	9 1-745496-0	
		3	#20-22	9 745496-9	
.125 .115	5	2	#22-26	9 745496-8	
		1	#26-30	9 745496-7	
.125 .115	4	3	#20-22	9 745496-6	
		2	#22-26	9 745496-5	
		1	#26-30	9 745496-4	
.125 .115	4	3	#20-22	9 745496-3	
		2	#22-26	9 745496-2	
		1	#26-30	9 745496-1	
PACKAGING	H	CONTACT FINISH	2	AWG WIRE RANGE	PART NUMBER

THIS DRAWING IS A CONTROLLED DOCUMENT.

DIMENSIONS: INCHES	TOLERANCES UNLESS OTHERWISE SPECIFIED:	DIN L VARELA - DOCKS 3/26/90	TE Connectivity
0 PLC ± -	1 PLC ± -	J. GERACE 11-16-04	PLUG ASSY, METAL SHELL, SIZE 3, 25 POSN, SERIES HDE-20 FOR MASS TERMINATION
2 PLC ± -	3 PLC ± .005	M. WALMSLEY 11-16-04	108-40011
4 PLC ± -	ANGLES ± °		114-40002
MATERIAL SEE CALL OUT	FINISH SEE TABLE	WEIGHT -	SIZE A1 00779 C=745496
		CUSTOMER DRAWING	SCALE 4:1 SHEET 1 OF 1 REV U1