

PART NUMBER	REV	FIRST USED
680001-1	B	565435-5

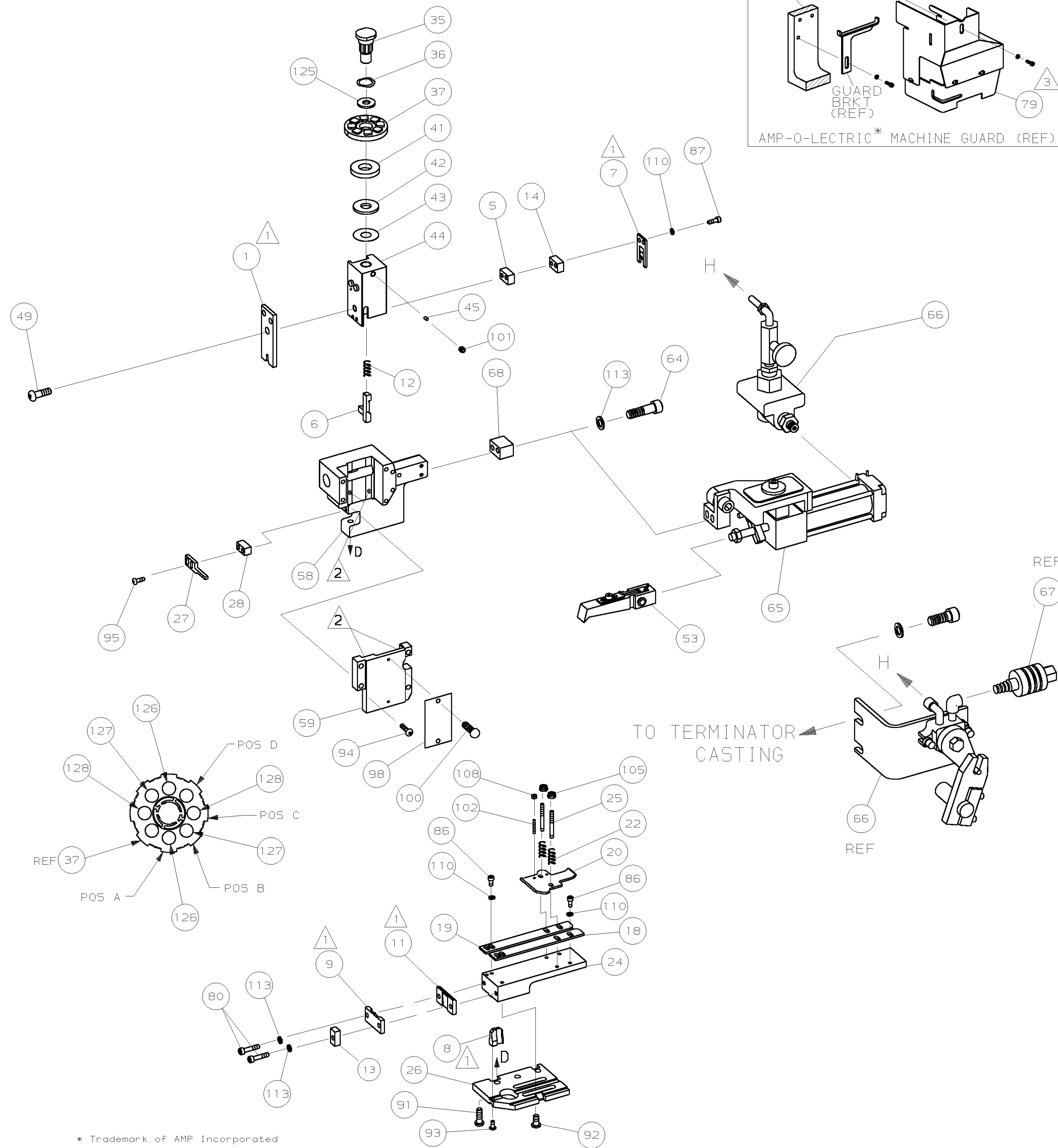
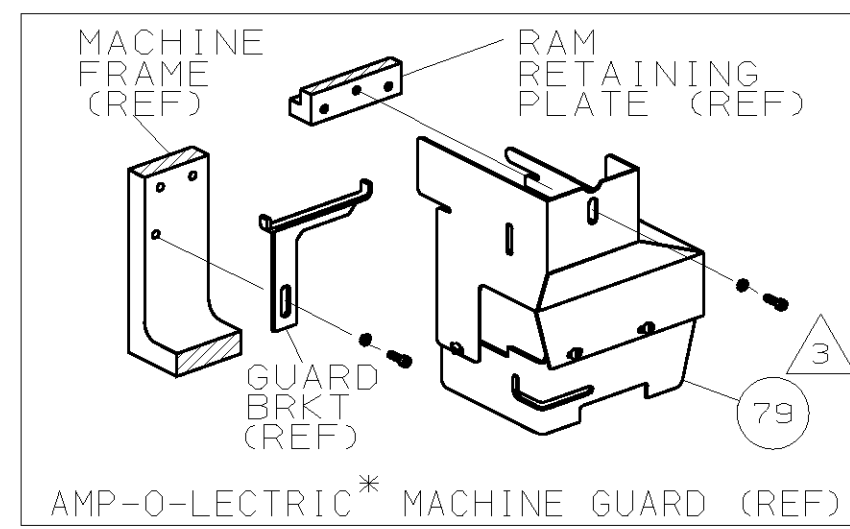

\* Trademark of AMP Incorporated

- 1 RECOMMENDED SPARE PARTS.
- 2 GREASE LIGHTLY.
- 3 GUARD MUST BE IN PLACE WHEN OPERATING APPLICATOR IN AMP-O-LECTRIC MACHINE.
- 4 SEE DRAWING FOR COMPONENTS

TERMINAL NAME:		CRIMPING DATA			
TAB, FASTIN-FASTON, AMPLIVAR 187 SERIES		PAD LTR	CRIMP HEIGHT	WIRE SIZE	
62447-2		A	.063 ±.002	(2) 19.5 OR (2) 20	
		B	.057 ±.002	19.5, 20 OR (2) 22	
		C	.054 ±.002	22	
		D	NOT	USED	
		CRIMP	SIZE	TYPE	RANGE
		WIRE	.110	F	22-19.5
		INSUL	-	-	-
		FEED	APPL INST	SET UP GAGE	LAYOUT
		1.065	A1 8039	458638-1	L1469
TERM APPL SPEC 114-02023		WIRE STRIP LENGTH		-	

QTY	REV	DESCRIPTION	PART NO	ITEM NO
2	-	PIN, WIRE DISC (.3060)C	1-354779-4	129
2	-	PIN, WIRE DISC (.3030)B	354779-8	128
2	-	PIN, WIRE DISC (.2970)A	9-354778-5	127
1	-	WASHER, FLAT PRECISION	986950-1	126
				124
				123
				122
				121
				120
				119
				118
				117
				116
				115
				114
4	-	WASHER, LOCK (NO. 10) SHEAR PL	21024-5	113
				112
				111
6	-	WASHER, LOCK (NO. 8) SHEAR BL	21024-4	110
				109
2	-	NUT, HEX (4-40) DRAG	21018-4	108
				107
				106
2	-	NUT, HEX SL (8-32) DRAG STUD	21022-2	105
				104
				103
2	-	SKT SKT SET (4-40x.75) DRAG	4-21078-8	102
1	-	SCR, SKT SET (1/4-20x.25 ) RAM	21009-2	101
2	-	SCR, DRIVE (#2x.19) ID PLATE	21017-2	100
				99
1	-	PLATE, IDENTIFICATION	461264-1	98
				97
				96
2	-	SCR, BHC (8-32x.50) STRIPPER	2-21002-2	95
4	-	SCR, BHC (10-32x.75) CAP	2-21002-9	94
1	-	SCR, BHC (8-32x.38 LW) ANVIL	22733-8	93
4	-	SCR, BHC (1/4-20x.50) ST 6D PL	3-21002-3	92
3	-	SCR, BHC (1/4-20x.62) H5G	2-22733-8	91
				90
				89
				88
2	-	SCR, 5HC (8-32x.75) SLUG BLADE	2-21000-9	87
4	-	SCR, 5HC (8-32x.25) STRIP GUIDE	2-21000-5	86
				85
				84
				83
				82
				81
2	-	SCR, SKT CAP (10-32x1.00) 5H PL	3-21000-9	80
1	-	GUARD ASSY	455750-8	79
				78
				77
				76
				75
				74
				73
				72
				71

QTY	REV	DESCRIPTION	PART NO	ITEM NO
				70
				69
				68
				67
				66
				65
				64
				63
				62
				61
				60
1	-	CAP, RAM	454220-1	59
1	-	HOUSING	453736-1	58
				57
				56
				55
				54
1	-	FEED FINGER ASSY	460680-1	53
				52
				51
				50
1	-	BOLT, CRIMPER (5/16-24x1.00)	7-21002-9	49
				48
				47
				46
1	-	PLUG, NYLON	690191-1	45
1	-	RAM	455674-1	44
1	-	WASHER, LAMINATED	690125-1	43
1	-	WASHER, RAM	690124-1	42
1	-	SPACER, INSULATION DISC	690223-2	41
				40
				39
				38
1	-	WIRE DISC, PLASTIC	354777-1	37
1	-	WASHER, SPRING	22480-5	36
1	-	POST, RAM	690212-1	35
				34
				33
				32
				31
				30
				29
1	-	SPACER, STRIPPER	3-690451-2	28
1	-	STRIPPER	240639-1	27
1	-	PLATE, BASE	455676-1	26
2	-	DRAG, STUD	22354-8	25
1	-	PLATE, STRIP GUIDE	455678-1	24
				23
2	-	SPRING, DRAG	4-22281-1	22
				21
1	-	DRAG, STOCK	454177-1	20
1	-	GUIDE, STRIP (REAR)	458030-9	19
1	-	GUIDE, STRIP (FRONT)	458031-9	18
				17
				16
				15
1	-	SPACER, SLUG BLADE	240641-1	14
1	-	SPACER, HOLD DOWN	1-690481-0	13
1	-	SPRING, HOLD DOWN	23846-1	12
1	-	PLATE, REAR SHEAR	240644-1	11
				10
1	-	PLATE, FRONT SHEAR	690482-1	9
1	-	ANVIL	1-456537-9	8
1	-	BLADE, SLUG	690474-2	7
1	-	HOLD DOWN, TERMINAL	455892-3	6
1	-	SPACER, SLUG BLADE	2-240641-7	5
				4
				3
				2
1	-	CRIMPER, WIRE	463223-1	1

REV	U/M	DWG SIZE	PART NO	DESCRIPTION	ITEM NO
-1				REVISION OF EACH ASSY NO (WHEN BLANK, USE DWG REVISION)	

REV	U/M	DWG SIZE	PART NO	DESCRIPTION	ITEM NO
-1				REVISION OF EACH ASSY NO (WHEN BLANK, USE DWG REVISION)	

LOC A  
DIST 66

DIMENSIONS IN INCHES. DO NOT SCALE PRINT. TOLERANCES UNLESS OTHERWISE SPECIFIED:  
 2 PLC DEC ±.25  
 3 PLC DEC ±.  
 4 PLC DEC ±.  
 ANGLES ±.  
 SURF TEXTURE: ✓  
 REMOVE BURRS, BREAK SHARP EDGES R.015 MAX

MATL - HT TR - FIN -  
 DR 4/15/93 APP -  
 M. O'BRINE -  
 CHK 4-20-93 REL -  
 C. ERISMAN -

AMP Incorporated Harrisburg, PA 17105-3608

NAME END FEED HDM APPLICATOR MACHINE REF  
 SCALE - DWG NO 680001 SHEET 1 OF 1 REV B