



Evaluation Kit for ADM1170, ADM1171, ADM1172

EVAL-ADM1170/ADM1171/ADM1172

PRODUCT DESCRIPTION

This evaluation board allows the ADM1170, ADM1171, and ADM1172 to be easily evaluated. These parts are hot swap controllers with enable input and gate pin output to drive an external FET. The hot swap control circuitry allows the boards to be safely inserted and removed from a live 1.6 V to 16.5 V backplane. The parts provide precise, robust, current-limiting protection against transient and nontransient short circuits as well as undervoltage and overcurrent conditions.

In addition to the standard hot swap functionality, the ADM1170 has an additional supply pin that allows voltage monitoring on a supply rail to go as low as 1.6 V. The ADM1171 features a current sense output (CSOUT) pin. The voltage on the CSOUT pin represents the voltage drop across the sense resistor gained up by a factor of 20. Both ADM1170 and ADM1171 feature a soft start function that provides the user with a capacitor programmable ramping reference to the internal current-sense comparator. This provides a linearly increasing current limit at startup at a rate set by the soft start capacitor (C_{SS}), which helps to reduce and limit large inrush currents. The ADM1172 features a power-fail comparator. The voltage on the PFI pin is compared with an internal 0.6 V reference, and the output of this comparator is presented on the PFO pin.

All these devices are available in two options: the ADM117x-1 with automatic retry for overcurrent fault and the ADM117x-2 with latch-off for an overcurrent fault. Toggling the ON (ON-CLR) pin resets a latched fault. All parts are packaged in an 8-lead TSOT.

Order codes for evaluation kits are shown in the Ordering Guide. (Pinouts and detailed package drawings can be found in the individual product data sheets.)

EVALUATION BOARD DESCRIPTION

The ADM1170/ADM1171/ADM1172 hot swap controller evaluation board contains all the necessary components for evaluating all features of the devices. This board requires a bench power supply of between 2.7 V and 16.5 V, connected through J1 and J3 or, alternatively, through the corresponding connectors on J4.

This board is capable of evaluating the ADM1170, ADM1171, and ADM1172 parts by simply changing certain connectors to suit specific evaluation plan.

Download the latest version of the configuration tool from Analog Devices, Inc., at www.analog.com/powermonitorsw.

PACKAGE CONTENTS

ADM1170/ADM1171/ADM1172 main evaluation board
ADM1170, ADM1171, and ADM1172 device samples

Rev. 0

Evaluation boards are only intended for device evaluation and not for production purposes. Evaluation boards are supplied "as is" and without warranties of any kind, express, implied, or statutory including, but not limited to, any implied warranty of merchantability or fitness for a particular purpose. No license is granted by implication or otherwise under any patents or other intellectual property by application or use of evaluation boards. Information furnished by Analog Devices is believed to be accurate and reliable. However, no responsibility is assumed by Analog Devices for its use, nor for any infringements of patents or other rights of third parties that may result from its use. Analog Devices reserves the right to change devices or specifications at any time without notice. Trademarks and registered trademarks are the property of their respective owners. Evaluation boards are not authorized to be used in life support devices or systems.

TABLE OF CONTENTS

Product Description.....	1	Timer Block.....	6
Evaluation Board Description.....	1	Sense Resistor and FET	6
Package Contents.....	1	Current Sense Output (CSO).....	6
Revision History	2	PFI/PFO Block.....	6
Evaluation Board Hardware.....	3	LEDs.....	6
Hardware Components.....	3	Pin Access.....	6
Switch, Jumper, and LED Functions	3	Additional Components.....	6
Operating the Evaluation Board.....	5	Evaluation Board Schematic	7
Additional Features	5	Ordering Information.....	8
Powering the Evaluation Board.....	5	Bill of Materials.....	8
ON (On- $\overline{\text{CLR}}$) Input Block.....	6	Ordering Guide	9
Soft Start Capacitors Block.....	6	ESD Caution.....	9

REVISION HISTORY

6/08—Revision 0: Initial Version

EVALUATION BOARD HARDWARE

HARDWARE COMPONENTS

Main Evaluation Board

The evaluation board contains all of the circuitry necessary to simulate real hot swap events such as a hot swap control FET, sense resistor, and timing components. It also has an adjustable resistor circuit to evaluate the performance of the power-fail comparator for the ADM1172 part.

Device Samples

Some loose samples of the device to be evaluated are included in a samples box. A single device should be placed in the socket before powering up the evaluation board. The device should be orientated in the socket such that Pin 1 is in the top left corner, near to U3.

SWITCH, JUMPER, AND LED FUNCTIONS

Table 1. Connector Functions

Switch	Description	Default
S1	ON (ON-CLR) pin setting switch	On
S1-ON	Device enable	
S1-OFF	Device disable	
S1-TOGGLE	Reset a latched fault (for ADM1170, ADM1171, and ADM1172 parts)	
S1_TIMER	Timer pin setting switch	
S1-1	Connects to a 22 nF capacitor, enables 5.7 ms initial delay and 476.6 μs circuit breaker delay	Closed
S1-2	Connects to a 47 nF capacitor, enables 12.2 ms initial delay and 1.01 ms circuit breaker delay	Open
S1-3	Connects to a 470 nF capacitor, enables 122.2 ms initial delay and 10.18 ms circuit breaker delay	Open
S1-4	Connects empty footprint for user-defined capacitor (CT4) on the TIMER pin	Open
S2-S	Soft start pin setting switch (ADM1170 and ADM1171 only)	
S2-1	Connects to a 1 nF capacitor, allowing 100 μs ramp-up delay	Closed
S2-2	Connects to a 10 nF capacitor, allowing 1 ms ramp-up delay	Open
S2-3	Connects to a 47 nF capacitor, allowing 4.7 ms ramp-up delay	Open
S2-4	Connects empty footprint for user-defined capacitor (CS4) on the SS pin	Open

Table 2. Jumper Functions

Jumper	Description	Default
LK_ON	Insert to enable manual enable/disable/reset control using Switch S1 or logic input on J1-1 (when S1 is on); deassert to use external logic signals on Connector J4-7 to control device enable/disable/reset	Inserted
LK_VCC	Applies to the ADM1170; insert to power device from main power rail; deassert to power device from Connector J4-1 for low voltage monitoring mode	Insert for ADM1170
LK_PFI	Applies to the ADM1172; link between the PFI pin and Potentiometer VR1; this allows the user to evaluate the performance of PFI on voltage input or voltage output; deassert if using Connector J4-8 for PFI input	Insert for ADM1172
PFI_IN	Applies to the ADM1172; allow VIN (Position A) or VOUT (Position B) to be linked with the PFI pin through Potentiometer VR1	Position B

Table 3. LED Functions

LED	Name	Description
D1	ON indicator	Indicates if the device is enabled
D2	PFO indicator	Indicates if the PFO output is present
D4	VOUT indicator	Indicates if the output voltage is present
D5	VIN indicator	Indicates if the supply voltage is present

EVAL-ADM1170/ADM1171/ADM1172

To configure an evaluation board to a specific device ensure the links in Table 4 are inserted.

Table 4. Configuration Links

Link	Description
CL1	Configuration link applies to ADM1170 and ADM1171
CL2	Configuration link applies to ADM1170
CL3	Configuration link applies to ADM1171 and ADM1172
CL4	Configuration link applies to ADM1172
CL5	Configuration link applies to ADM1171 and ADM1172
CL6	Configuration link applies to ADM1170

Table 5. Soft Start Capacitor Value and Delay Time Reference to the Configuration of Switch S2_S

Switch	Capacitor Value	Delay Time
1	1 nF	100 μ s
2	10 nF	1 ms
3	47 nF	4.7 ms
4	User Defined	User Defined

Table 6. Timer Capacitor Value and Delay Time Reference to the Configuration of Switch S1_TIMER

Switch	Capacitor Value	Initial Delay— $t_{INITIAL}$	Circuit Breaker Delay— t_{CB}
1	22 nF	5.7 ms	476.6 μ s
2	47 nF	12.2 ms	1.01 ms
3	470 nF	122.2 ms	10.18 ms
4	User Defined	User Defined	User Defined

OPERATING THE EVALUATION BOARD

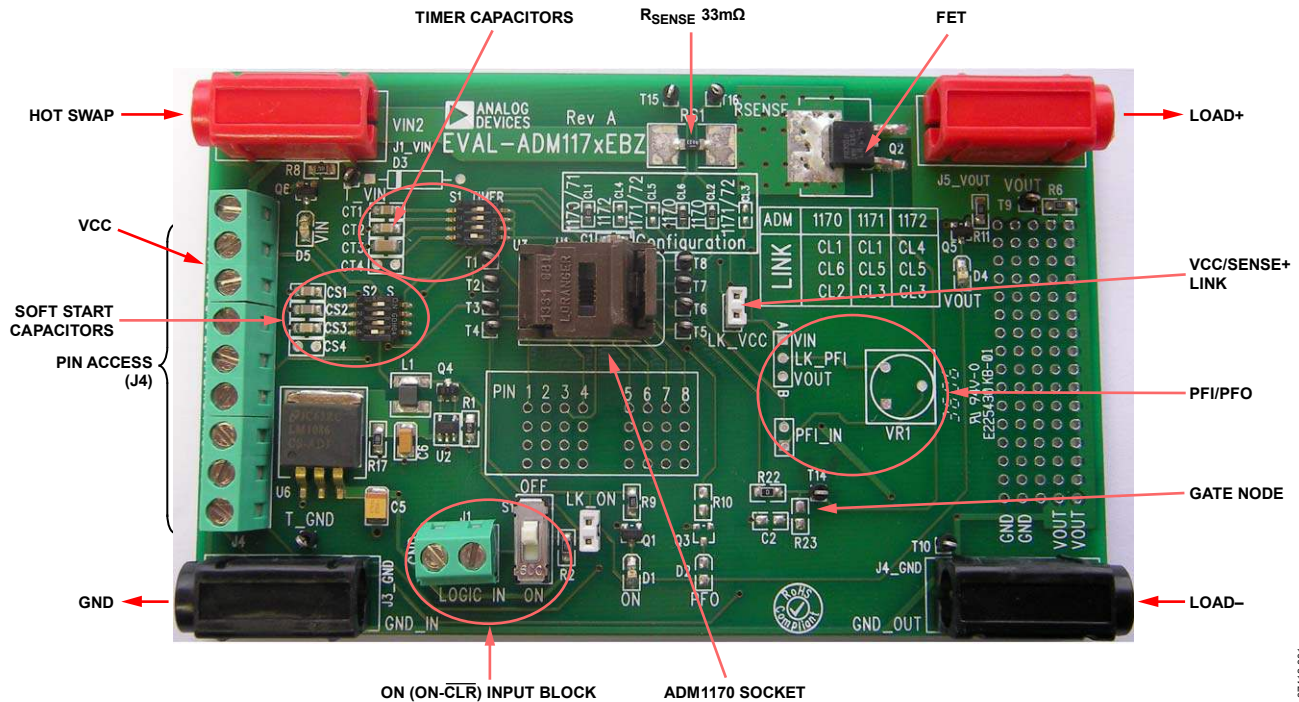

Figure 1. Evaluation Board

The ADM1170, ADM1171, and ADM1172 devices are integrated hot swap controllers and current-sense amplifiers. An internal current-sense amplifier senses voltage across the sense resistor in the power path via the V_{CC} and SENSE pins (SENSE+ and SENSE- pins for the ADM1170). The ADM1170, ADM1171, and ADM1172 limit the current through this resistor by controlling the gate voltage of an external N-channel FET in the power path via the GATE pin. The sense voltage (and hence the inrush current) is kept below a preset maximum. The ADM1170, ADM1171, and ADM1172 protect the external FET by limiting the time that it spends with the maximum current running in it. This current-limit period is set by the choice of capacitor attached to the TIMER pin.

Additionally, the device provides protection from overcurrent events at times after the hot swap event is complete. In the case of a short-circuit event, the current in the sense resistor exceeds an overcurrent trip threshold, and the FET is switched off immediately by pulling down the GATE pin.

The ADM1170, ADM1171, and ADM1172 are packaged in an 8-lead TSOT.

ADDITIONAL FEATURES

ADM1170

The ADM1170 has an additional supply pin that allows voltage monitoring on a supply rail to go as low as 1.6 V, and a soft start function, which provides a capacitor programmable ramping reference to the internal current-sense comparator.

ADM1171

The ADM1171 has a current sense output (CSOUT) pin. The voltage on the CSOUT pin represents the voltage drop across the sense resistor gained up by a factor of 20. It also contains a soft start function, which provides a capacitor programmable ramping reference to the internal current sense comparator.

ADM1172

The ADM1172 has a power-fail comparator output, for which the voltage on the PFI pin is compared with an internal 0.6 V reference, and the output of this comparator is presented on the PFO pin.

POWERING THE EVALUATION BOARD

The ADM1170/ADM1171/ADM1172 evaluation board is powered using a bench supply of between 2.7 V and 16.5 V, connected to J1_VIN and J3_GND for ground. In this case, the device is powered from the voltage input rail. Alternatively, connectors on J4 can be used to power up the device. The load can be connected between the red and black connectors, J5_VOUT and J4_GND respectively.

EVAL-ADM1170/ADM1171/ADM1172

The ADM1170 has a separate V_{CC} pin and a SENSE+ pin, which allow the device to hot swap low voltage rails while being powered from a different supply. Jumper LK_VCC allows V_{CC} to be shorted to SENSE+ in order to power the device and hot swap from the same rail (J1_VIN). By deasserting LK_VCC, the ADM1170 device can be powered through the V_{CC} pin on the J4 connector block; this enables the device to monitor a low level voltage input from Connector J1_VIN or the VIN pin on the J4 connector block.

ON (ON-CLR) INPUT BLOCK

The ADM1170, ADM1171, and ADM1172 are available in two options ADM1170-1, ADM1171-1, ADM1172-1 and ADM1170-2, ADM1171-2, ADM1172-2. The ADM1170-1, ADM1171-1, and ADM1172-1 have an autoretry function that keeps retrying to clear a fault and the ADM1170-2, ADM1171-2, and ADM1172-2 latch off until the ON pin is toggled. If Jumper LK_ON is inserted, S1 is connected to the ON (ON-CLR) pin. Remove this jumper to connect an external signal to the pin using the J4 pin connect block. Note there is also a 2-pin input connector (J1) located near the S1 switch, which also allows the user to connect an ON (ON-CLR) signal to the device without removing the jumper. The green LED (D1) is used to indicate the status of the pin.

SOFT START CAPACITORS BLOCK

The ADM1170 and ADM1171 have a soft start function to limit the inrush current by controlling the rate at which the gate ramps up. This is achieved by slowly increasing the I_{LIMIT} voltage from 0 mV to 50 mV via a current of 10 μ A being injected into the soft start capacitor. When the voltage reached 1 V on the SS pin then the I_{LIMIT} is at its normal operation of 50 mV. This pin can also be accessed by the J4 block connector where it can be used to reduce the fault limit on the device by overdriving or clamping the voltage. The ADM1170 limits current when 50 mV is reached across the SENSE+ and SENSE- pins (V_{CC} and SENSE pins for ADM1171 and the ADM1172). There are three capacitors connectable via dipswitches (S2_S) on the board and another empty footprint for any additional capacitors. A capacitor is chosen as follows:

$$t = V \times C/I$$

where:

t is the time required to reach a normal 50 mV limit.

V is 1 V.

C is a capacitor.

I is 10 μ A.

Thus, $C = t \times 10 \times 10^{-6}$. Table 5 shows the available options.

TIMER BLOCK

The ADM1170, ADM1171, and ADM1172 are available in both autoretry and latched-off versions, ADM1170-1, ADM1171-1, ADM1172-1 and ADM1170-2, ADM1171-2, and ADM1172-2, respectively. The TIMER capacitor is used to control both the startup timing cycle and the circuit breaker delay. The timing delays are calculated by the following equations:

$$t_{INITIAL} = 1.3 V \times C_{TIMER}/5 \mu A$$

$$t_{CB} = 1.3 V \times C_{TIMER}/60 \mu A$$

Table 6 shows the available dip switch (S1_TIMER) options.

SENSE RESISTOR AND FET

There is a 33 m Ω sense resistor fitted as standard and a typical FET, details of both are found in the Bill of Materials. However, footprints are supplied to easily change the FET and sense resistor to the many different common footprints that may be required.

CURRENT SENSE OUTPUT (CSO)

For the ADM1171, the CSOUT pin can be monitored through the block connector J4, pin labeled PIN6.

PFI/PFO BLOCK

The ADM1172 has an integrated comparator and reference allowing the user to monitor the voltage for power-fail conditions. Jumper LK_PFI allows the user to select between input or output voltage monitoring. The threshold can be set using Potentiometer VR1. Jumper PFI_IN is used to isolate the output of VR1 from the PFI pin of the ADM1172. This may be required when another voltage needs to be monitored or an external resistor divider is used. The PFO LED shows the status of the PFO output.

LEDS

A green LED located near the VIN and VOUT connectors is used to indicate if power is present. Switch S1 also has a green LED located nearby to indicate the status of the ON (ON-CLR) pin. These LEDs are powered from a LED driver circuit, which ensures a constant level of brightness across the various supply voltage ranges.

PIN ACCESS

Pin access is available through a connector block (J4) on the left edge of the board.

ADDITIONAL COMPONENTS

Additional components can be placed in the center of the board where holes have been placed (see the outlined section in the center of the board in Figure 1). Access to all pins is available through the top row. There is also such an area at the right edge of the board to allow loads to be soldered to the board.

EVALUATION BOARD SCHEMATIC

07418-002

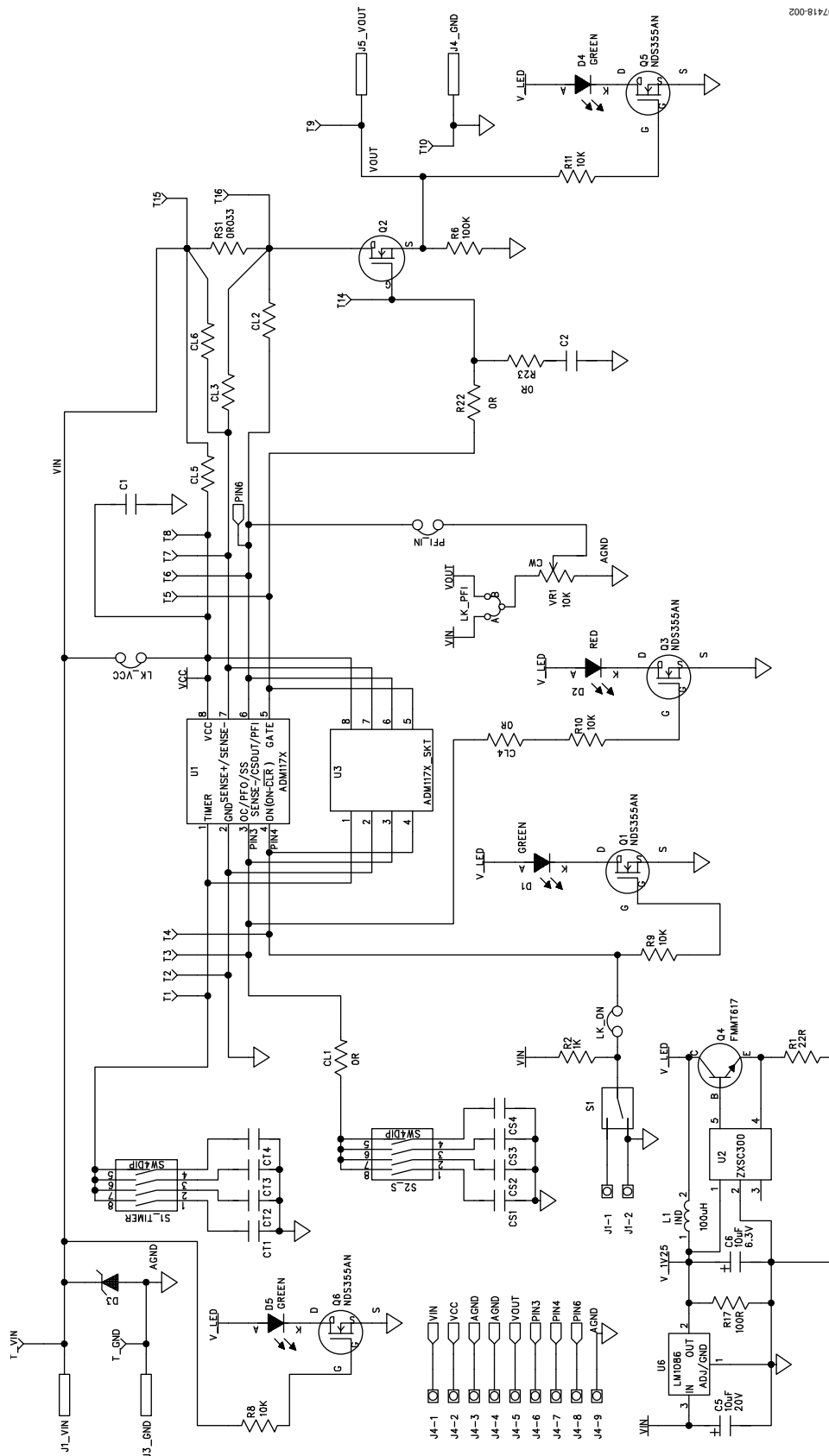

EVAL-ADM1170/ADM1171/ADM1172

ORDERING INFORMATION

BILL OF MATERIALS

Table 7.

Qty	Reference Designator	Description	Manufacturer	Manufacturer Number
1	C1	0.1 μ F capacitor, 0805 100 nF 50 V	Multicomp	U0805R104KCT
1	C2	Not placed		
1	C5	10 μ F capacitor, Case B 10 μ F 20 V	AVX	TAJB106K020R
1	C6	10 μ F capacitor, Case A 10 μ F 6.3 V	AVX	TAJA106K006R
6	CL1, CL2, CL3, CL4, CL5, CL6	0 Ω		
1	CS1	1 nF capacitor, 0805 50 V	Multicomp	U0805R102KCT
1	CS2	10 nF capacitor, 0805 50 V	Multicomp	U0805R103KCT
2	CS3, CT2	47 nF capacitor, 0805 50 V	Multicomp	U0805R473KCT
1	CS4	Not placed		
1	CT1	22 nF capacitor, 0805 50 V	Multicomp	U0805R223KCT
1	CT3	470 nF capacitor, 1206, 25 V	Multicomp	T1206R474KCT
1	CT4	Not placed		
3	D1, D4, D5	LED, SMD green	Kingbright Corp.	KP-2012SGC
1	D2	LED, SMD red	Kingbright Corp.	KP-2012SRC-PRV
1	D3	Custom generic Zener-diode add-in if operated with a high noise supply		Generic Zener diode
1	J1	Terminal block, PCB 2-way	Lumberg Automation	KRM 02
4	J1_VIN, J3_GND, J4_GND, J5_VOUT	Socket, 4 mm PCB red	Deltron, LLC.	571-0500-01
1	J4	Terminal block, PCB 3-way	Lumberg Automation	KRM 03
1	L1	100 μ H inductor, 1210	Murata Electronics	LQH32MN101J23L
3	LK_ON, PFI_IN, LK_VCC	Header, 1 row 2-way Jumper socket, red	Harwin	M20-9990246 M7566-05
1	LK_PFI	Header, 1 row 3-way Jumper socket, red	Harwin	M20-9990346 M7566-05
4	Q1, Q3, Q5, Q6	MOSFET, N-channel SOT-23	Fairchild Semiconductor	NDS355AN
1	Q2	MOSFET, N-channel D-PAK	International Rectifier	IRFR3518PBF
1	Q4	Transistor, NPN SOT-23	Zetex, Inc.	FMMT617
1	R1	22 Ω resistor, 0805	Multicomp	MC 0.1W 0805 1% 22R
4	R8, R9, R10, R11	10 k Ω resistor, 0805	Multicomp	MC 0.1W 0805 1% 10k
1	R2	1 k Ω resistor, 0805	Multicomp	MC 0.1W 0805 1% 1K
1	R6	100 k Ω resistor, 0805	Multicomp	MC 0.1W 0805 1% 100K
1	R17	100 Ω resistor, 0805	Multicomp	MC 0.1W 0805 1% 100R
2	R22, R23	0 Ω resistor, 0805	Multicomp	MC 0.1W 0805 0R
1	RS1	0.033 Ω resistor, 1206	Tyco Electronics	TL2BR033FTE
1	S1	Switch, slide SP 2 POS VERT	ALPS ELECTRIC CO., LTD.	STSSS9121
2	S1_TIMER, S2_S	Switch, DIP 4-way	Tyco Electronics/ Alcoswitch	GDH04S
15	T1, T2, T3, T4, T5, T6, T7, T8, T9, T10, T14, T15, T16, T_GND, T_VIN	Terminal, PCB black PK100	Vero Technologies	20-2137
1	VR1	Trimmer, 10 k Ω	Vishay Spectrol	63M-T607-103
1	U1	ADM1170/ADM1171/ADM1172	Analog Devices	ADM117x
1	U2	IC, SM LED driver	Zetex, Inc.	ZXSC300E5TA
1	U3	SOT-23, 8-pin socket	Loranger Intl	04334 081 6215
1	U6	IC, SM 1.5 A LDO regulator	National Semiconductor	LM1086CS-ADJ

ORDERING GUIDE

Model	Description
EVAL-ADM1170EBZ ¹	ADM1170 Evaluation Board
EVAL-ADM1171EBZ ¹	ADM1171 Evaluation Board
EVAL-ADM1172EBZ ¹	ADM1172 Evaluation Board

¹ Z = RoHS Compliant Part.

ESD CAUTION



ESD (electrostatic discharge) sensitive device. Charged devices and circuit boards can discharge without detection. Although this product features patented or proprietary protection circuitry, damage may occur on devices subjected to high energy ESD. Therefore, proper ESD precautions should be taken to avoid performance degradation or loss of functionality.

NOTES

NOTES

NOTES