

DO NOT SCALE FROM THIS PRINT

DESIGNED & DIMENSIONED IN INCHES[MILLIMETERS]

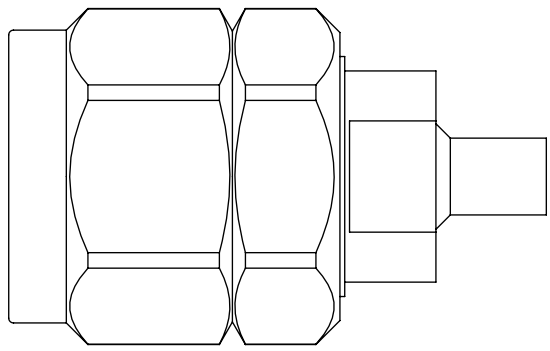
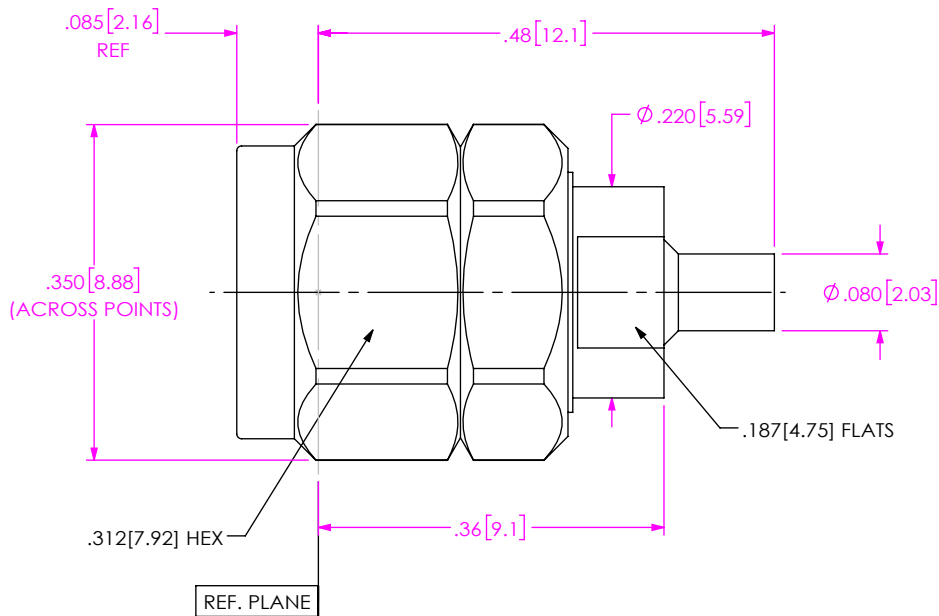

EXPLODED VIEW
NOT TO SCALE
(FOR CLARITY ONLY)

PRF18-P-C-EE-047H-SD

SERIES -18: 1.85MM
GENDER -P: PLUG
TYPE -C: CABLE
FINISH -EE: 50µ" EXTRA HEAVY GOLD CENTER CONTACT, 50µ" EXTRA HEAVY GOLD OUTER BODY
TERMINATION -D: DIRECT SOLDER
ORIENTATION -S: STRAIGHT
CABLE TYPE -047H: EZ-47-LA SEMI-RIGID

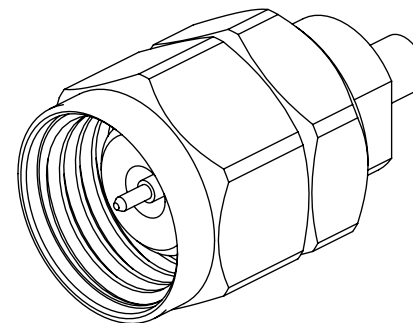

NOTES:

- MATERIAL:
BUSHING & COUPLING NUT: STAINLESS STEEL
BODY, CONTACT & LOCK RING: BERYLLIUM COPPER
SUPPORT BEADS: PTFE
DIELECTRIC BEAD: ULTEM 1000
GASKET: SILICONE RUBBER
- FINISH:
COUPLING NUT & BUSHING: PASSIVATED
BODY & CONTACT: 50µ" MIN. GOLD OVER 50µ" MIN. NICKEL PLATE
- PCI P/N: 4131

c:\enterprisevault\DWG\MISC\MKTG\PRF18-P-C-EE-047H-SD-MKT.SLDDRW

UNLESS OTHERWISE SPECIFIED, DIMENSIONS ARE IN INCHES. TOLERANCES ARE: DECIMALS ANGLES .XX: ±.02[0.5] 1° .XXX: ±.005[0.13] .XXXX: ±.0005[0.013]	* PROPRIETARY NOTE * THIS DOCUMENT CONTAINS CONFIDENTIAL AND PROPRIETARY INFORMATION AND ALL DESIGN, MANUFACTURING, REPRODUCTION, USE, PATENT RIGHTS AND SALES RIGHTS ARE EXPRESSLY RESERVED BY SAMTEC, INC. THIS DOCUMENT SHALL NOT BE DISCLOSED, IN WHOLE OR PART, TO ANY UNAUTHORIZED PERSON OR ENTITY NOR REPRODUCED, TRANSFERRED OR INCORPORATED IN ANY OTHER PROJECT IN ANY MANNER WITHOUT THE EXPRESS WRITTEN CONSENT OF SAMTEC, INC.	 520 PARK EAST BLVD., NEW ALBANY, IN 47150 PHONE: 812-944-6733 FAX: 812-948-5047 e-Mail: info@SAMTEC.com code 55322
		DESCRIPTION: 1.85MM PLUG, DIRECT SOLDER FOR EZ-47-LA SEMI-RIGID CABLE
		DWG. NO. PRF18-P-C-EE-047H-SD
DO NOT SCALE DRAWING SHEET SCALE: 5:1	BY: ETHAN C 12/14/2020 SHEET 1 OF 2	

CABLE APPLICATION VIEWS

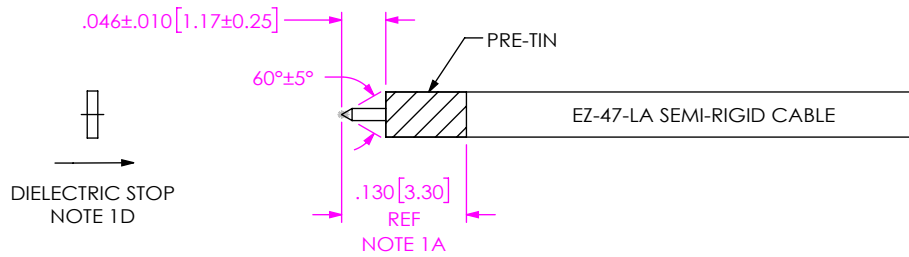

- 1A. PRE-TIN CABLE OUTER JACKET OVER APPROX. LENGTH SHOWN.
- 1B. TRIM CABLE TO EXPOSE CENTER CONDUCTOR AS SHOWN.
- 1C. POINT CENTER CONDUCTOR AS INDICATED.
- 1D. SLIDE DIELECTRIC STOP ONTO CENTER CONDUCTOR AGAINST CABLE FACE.

IN-PROCESS 1

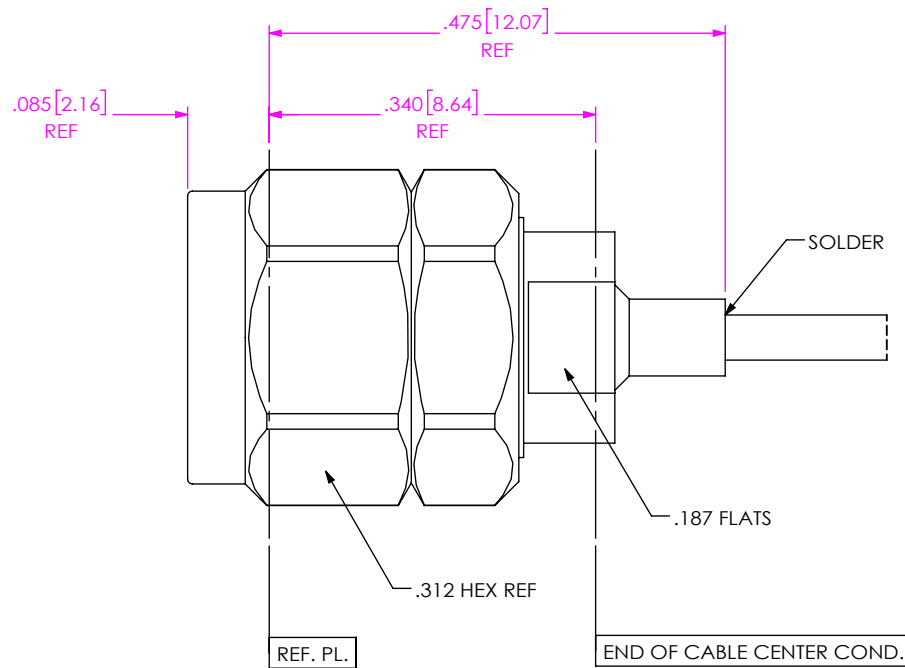

- 2A. INSERT CABLE INTO CONNECTOR UNTIL CENTER CONDUCTOR PLUGS IN AND CABLE SEATS IN CONNECTOR BORE.
- 2B. SOLDER CABLE JACKET TO BODY WHERE SHOWN APPLYING HEAT TO EXTENDED BODY TAIL.

IN-PROCESS 2

<p>PROPRIETARY NOTE</p> <p>THIS DOCUMENT CONTAINS CONFIDENTIAL AND PROPRIETARY INFORMATION AND ALL DESIGN, MANUFACTURING, REPRODUCTION, USE, PATENT RIGHTS AND SALES RIGHTS ARE EXPRESSLY RESERVED BY SAMTEC, INC. THIS DOCUMENT SHALL NOT BE DISCLOSED, IN WHOLE OR PART, TO ANY UNAUTHORIZED PERSON OR ENTITY NOR REPRODUCED, TRANSFERRED OR INCORPORATED IN ANY OTHER PROJECT IN ANY MANNER WITHOUT THE EXPRESS WRITTEN CONSENT OF SAMTEC, INC.</p>	 <p>520 PARK EAST BLVD, NEW ALBANY, IN 47150 PHONE: 812-944-6733 FAX: 812-948-5047 e-Mail info@SAMTEC.com code 55322</p>	
	<p>DESCRIPTION: 1.85MM PLUG, DIRECT SOLDER FOR EZ-47-LA SEMI-RIGID CABLE</p>	
<p>DO NOT SCALE DRAWING</p> <p>SHEET SCALE: 5:1</p>	<p>DWG. NO. PRF18-P-C-EE-047H-SD</p>	
<p>BY: ETHAN C 12/14/2020</p>		<p>SHEET 2 OF 2</p>