

11.90	13.54	504622-7070	o	---	70
10.85	12.49	504622-6470	o	---	64
10.15	11.79	504622-6070	---	---	60
9.10	10.74	504622-5470	---	---	54
8.40	10.04	504622-5070	o	---	50
8.05	9.69	504622-4870	---	---	48
7.00	8.64	504622-4270	---	---	42
6.65	8.29	504622-4070	o	---	40
5.60	7.24	504622-3470	o	---	34
4.90	6.54	504622-3070	o	---	30
3.85	5.49	504622-2470	o	---	24
3.15	4.79	504622-2070	o	---	20
2.80	4.44	504622-1870	---	---	18
2.45	4.09	504622-1670	---	---	16
1.75	3.39	504622-1270	---	---	12
1.40	3.04	504622-1070	o	---	10
0.70	2.34	504622-0670	---	---	6

B	A	EMBOSSSED TAPE PACKAGE	HIGH VOL. TOOL	LOW VOL. TOOL	CIRCUIT
		ORDER NO.	SAMPLE PREPARATION o : TOOLED Δ : WORK IN PROCESS --- : TOOLING TO BE CONFIRMED		

CONNECTOR SERIES No. : 504622-**79

NOTES

- MATERIAL
WAFER : LIQUID CRYSTAL POLYMER UL94V-0(COLOR : BLACK)
PIN : COPPER ALLOY
FITTING NAIL : COPPER ALLOY
- PLATING
TERMINAL
GOLD
UNDER PLATING : NICKEL
*DIVIDE INTO PARTS THE GOLD PLATING OF THE CONTACT AND THE TAIL PART BY THE NICKEL PLATING.
FITTING NAIL
GOLD
UNDER PLATING : NICKEL
- APPLY FOR (CIRCUIT/2)-EVEN.
- MATE WITH : 504618-**10
- TAIL AND FITTING NAIL COPLANARITY TO BE 0.08MAXIMUM.
PROHIBITED AREA OF PATTERN WIRING AND SOLDER.
(FOR EACH AREA, THE WIRING THAT TOUCHES ON THE SOLDER CAN BE ATTACHED, THEN COVERED WITH A FILM TO KEEP SOLDER OUT.)
- ELV and RoHS COMPLIANT.
- ELECTRIC SPEC OF FITTING NAIL IS NOT GUARANTEED WHEN MATED.

REVISED EC NO: J2015-0705 DRWN:MYOSHIDA 2014/11/26 CHKD:RTAKEUCHI 2014/11/26 APPR:KMORIKAWA 2014/12/03	DESCRIPTION REV	GENERAL TOLERANCES (UNLESS SPECIFIED)		DIMENSION STYLE MM ONLY	SCALE 20:1	DESIGN UNITS METRIC	THIRD ANGLE PROJECTION	
		10 UNDER ±0.2	10 OVER 30 UNDER ±0.25	DRAWN BY HON001	DATE 2014/02/24	TITLE 0.35 BB CONN. H=0.6 SSB6 PLUG ASSY CHECKER TYPE.		
		30 OVER ±0.3	ANGULAR ±1 °	CHECKED BY RTAKEUCHI	DATE 2014/02/24	APPROVED BY KMORIKAWA 2014/08/11		
		DRAFT WHERE APPLICABLE MUST REMAIN WITHIN DIMENSIONS		MATERIAL NO. SEE CHART	DOCUMENT NO. SD-504622-003	SHEET NO. 1 OF 2		

THIS DRAWING CONTAINS INFORMATION THAT IS PROPRIETARY TO MOLEX INCORPORATED AND SHOULD NOT BE USED WITHOUT WRITTEN PERMISSION

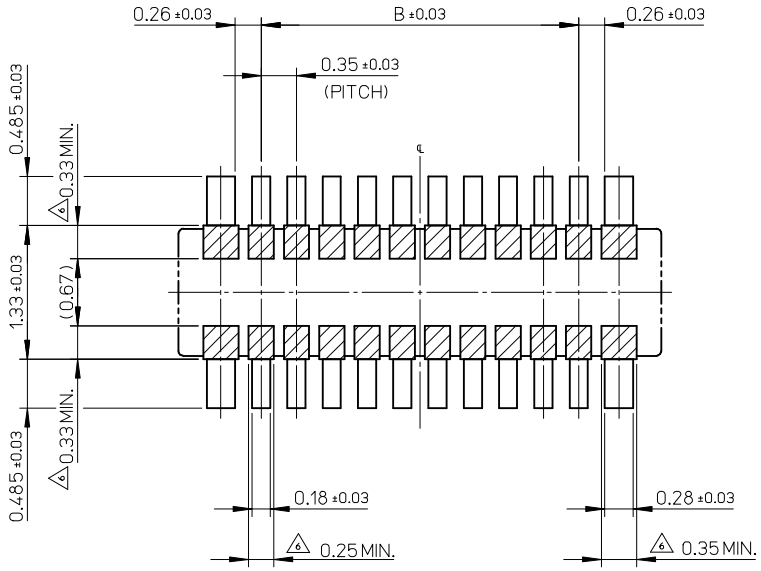

RECOMMENDED P.W.BOARD PATTERN LAYOUT(REFERENCE)

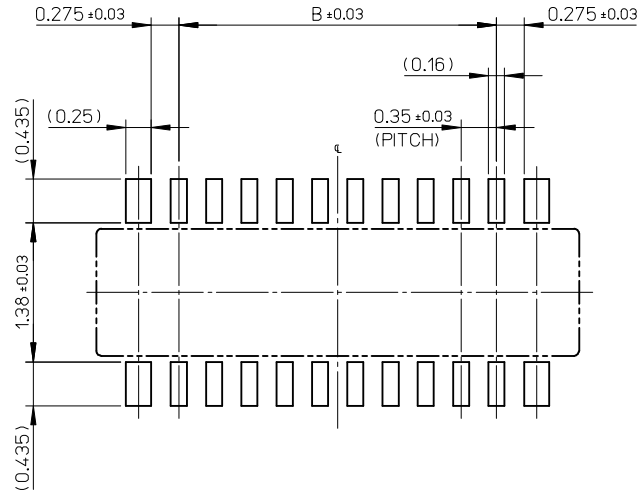

RECOMMENDED METAL MASK LAYOUT(REFERENCE)

RECOMMENDED THICKNESS OF METAL MASK : t=0.08mm
 RECOMMENDED OPEN APERTURE RATIO OF METAL MASK : 80%

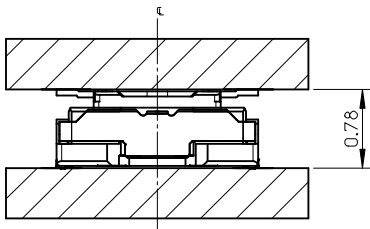

MATED CONDITION

REVISED EC NO: J2015-0705 DRWN:MYOSHIDA 2014/11/26 CHKD:RTAKEUCHI 2014/11/26 APPR:KMORIKAWA 2014/12/03	GENERAL TOLERANCES (UNLESS SPECIFIED)		DIMENSION STYLE MM ONLY	SCALE 20:1	DESIGN UNITS METRIC	THIRD ANGLE PROJECTION
	10 UNDER	± 0.2	DRAWN BY HON001	DATE 2014/02/24	TITLE	
	10 OVER 30 UNDER	± 0.25	CHECKED BY RTAKEUCHI	DATE 2014/02/24	0.35 BB CONN. H=0.6 SSB6 PLUG ASSY CHECKER TYPE.	
	30 OVER	± 0.3	APPROVED BY KMORIKAWA	DATE 2014/08/11		
ANGULAR	± 1 °	MATERIAL NO. SEE SHEET 1		DOCUMENT NO. SD-504622-003	SHEET NO. 2 OF 2	
DRAFT WHERE APPLICABLE MUST REMAIN WITHIN DIMENSIONS		THIS DRAWING CONTAINS INFORMATION THAT IS PROPRIETARY TO MOLEX INCORPORATED AND SHOULD NOT BE USED WITHOUT WRITTEN PERMISSION				

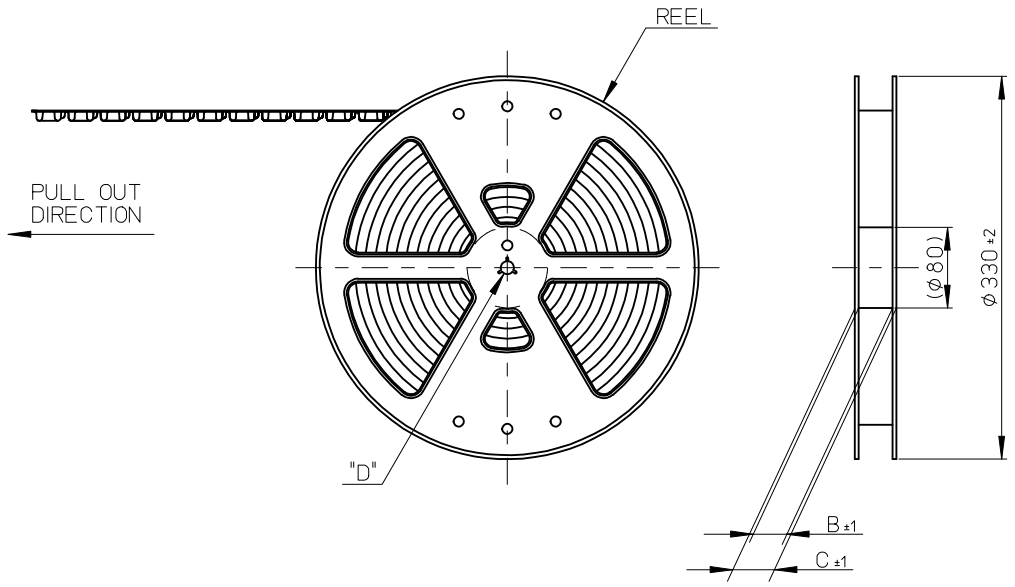

NOTES

1. RE DETAILED DIMENSION, SEE PRODUCT DRAWING.
2. NUMBER OF CONNECTORS : 3000PCS/REEL
3. LEAD TAPE LENGTH
4. TOP TAPE PEEL FORCE IS DEFINED BY IEC60286-3.
5. MATERIAL
 CARRIER TAPE : POLYSTYRENE
 TOP TAPE : PET , OTHER
 REEL : POLYSTYRENE (PS) <RECYCLE MATERIAL CONTAINED>
6. ELV AND RoHS COMPLIANT

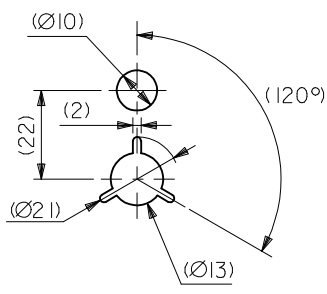

DETAIL "D"

REVISED EC NO: J2015-0705 DRWN:MYOSHIDA 2014/11/26 CHKD:RTAKEUCHI 2014/11/26 APPR:KMORIKAWA 2014/12/03	GENERAL TOLERANCES (UNLESS SPECIFIED)		DIMENSION STYLE	SCALE	MODEL NO.	504622-**70	
	10 UNDER ± 0.2		MM ONLY	1:5	DESIGN UNITS	METRIC	
	10 OVER 30 UNDER ± 0.25		DRAWN BY	DATE	TITLE	0.35 BB CONN. H=0.6 SSB6 PLUG ASSY CHECKER TYPE EMBSTP PKG	
	30 OVER ± 0.3		HON001	2014/02/24			
ANGULAR ± 1 °		CHECKED BY	DATE	THIRD ANGLE PROJECTION			
DRAFT WHERE APPLICABLE MUST REMAIN WITHIN DIMENSIONS		RTAKEUCHI	2014/02/24	DOCUMENT NO. SD-504622-004			
		APPROVED BY	DATE	SHEET NO. 1 OF 3			
		KMORIKAWA	2014/08/11	THIS DRAWING CONTAINS INFORMATION THAT IS PROPRIETARY TO MOLEX INCORPORATED AND SHOULD NOT BE USED WITHOUT WRITTEN PERMISSION			
		MATERIAL NO.					
		SIZE	A3				

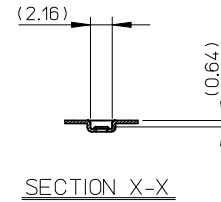
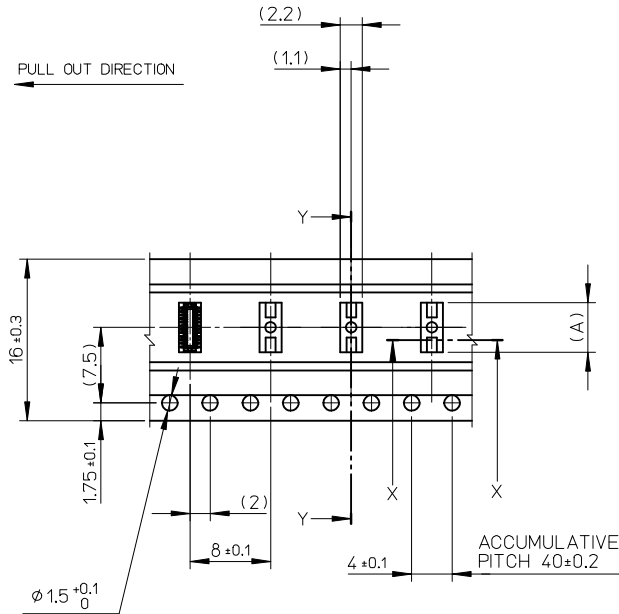
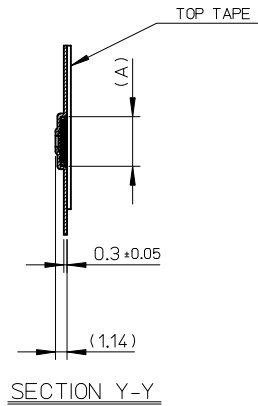

16	21.4	17.4	6.68	504622-3070	o	---	30	
			5.63	504622-2470	o	---	24	
			4.93	504622-2070	o	---	20	
			4.58	504622-1870	---	---	18	
			4.23	504622-1670	---	---	16	
			3.53	504622-1270	---	---	12	
			3.18	504622-1070	o	---	10	
2.48	504622-0670	---	---	6				
キャリアテープ幅 CARRIER TAPE WIDTH		C	B	(A)	EMBOSSED TAPE PACKAGE	HIGH VOL. TOOL	LOW VOL. TOOL	CIRCUIT
ORDER NO.				SAMPLE PREPARATION o : TOOLED △ : WORK IN PROCESS --- : TOOLING TO BE CONFIRMED				

REVISED EC NO: J2015-0705 DRWN: MYOSHIDA 2014/11/26 CHKD: RTAKEUCHI 2014/11/26 APPR: KMORIKAWA 2014/12/03	GENERAL TOLERANCES (UNLESS SPECIFIED)		DIMENSION STYLE MM ONLY		SCALE 2:1	DESIGN UNITS METRIC	THIRD ANGLE PROJECTION
	10 UNDER	± 0.2	DRAWN BY HON001	DATE 2014/02/24	TITLE 0.35 BB CONN. H=0.6 SSB6 PLUG ASSY CHECKER TYPE EMBSTP PKG		
	10 OVER 30 UNDER	± 0.25	CHECKED BY RTAKEUCHI	DATE 2014/02/24			
	30 OVER	± 0.3	APPROVED BY KMORIKAWA	DATE 2014/08/11			
ANGULAR ± 1 °		DRAFT WHERE APPLICABLE MUST REMAIN WITHIN DIMENSIONS		MATERIAL NO.	SEE CHART	DOCUMENT NO. SD-504622-004	SHEET NO. 2 OF 3
THIS DRAWING CONTAINS INFORMATION THAT IS PROPRIETARY TO MOLEX INCORPORATED AND SHOULD NOT BE USED WITHOUT WRITTEN PERMISSION							

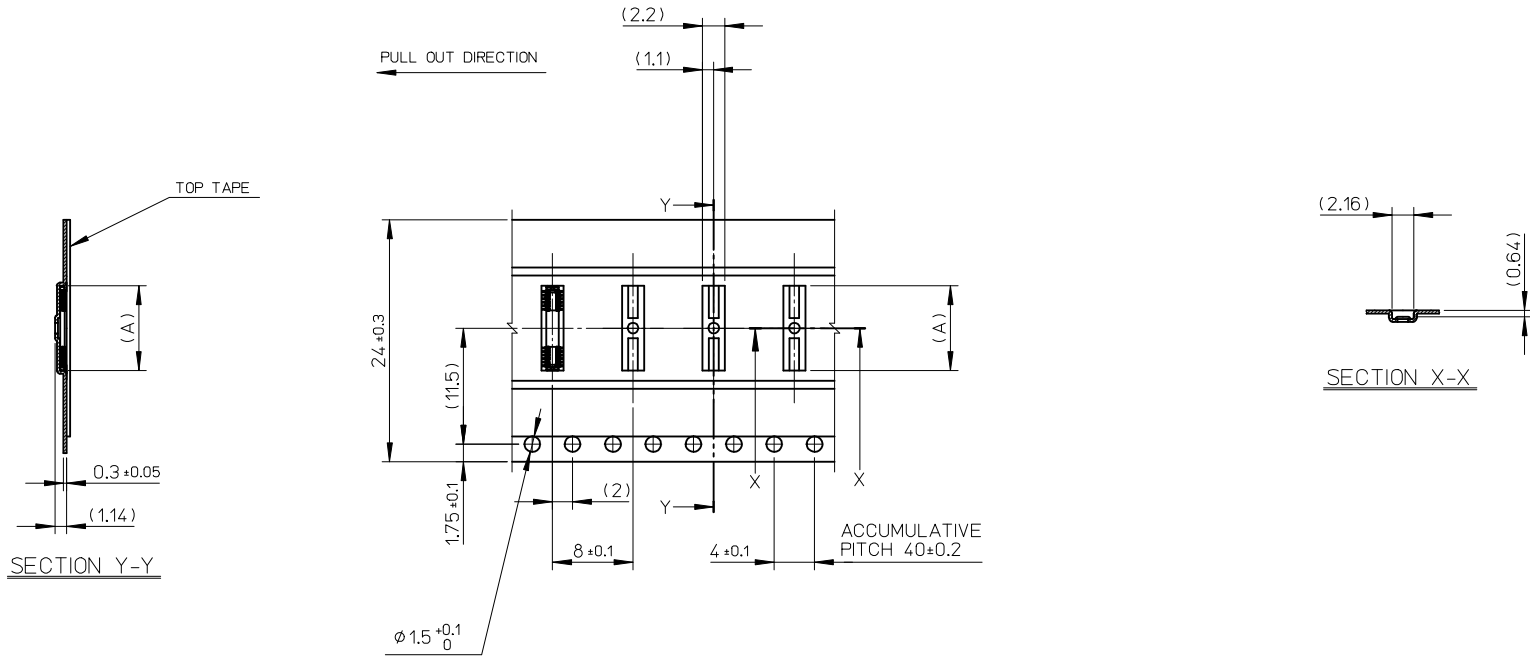

24	29.4	25.4	13.68	504622-7070	o	---	70		
			12.63	504622-6470	o	---	64		
			11.93	504622-6070	---	---	60		
			10.88	504622-5470	---	---	54		
			10.18	504622-5070	o	---	50		
			9.83	504622-4870	---	---	48		
			8.78	504622-4270	---	---	42		
			8.43	504622-4070	o	---	40		
7.38	504622-3470	o	---	34					
キャリアテープ幅 CARRIER TAPE WIDTH			C	B	(A)	EMBOSSED TAPE PACKAGE	HIGH VOL. TOOL	LOW VOL. TOOL	CIRCUIT
			ORDER NO.		SAMPLE PREPARATION o : TOOLED Δ : WORK IN PROCESS --- : TOOLING TO BE CONFIRMED				

REVISED EC NO: J2015-0705 DRWN: MYOSHIDA 2014/11/26 CHKD: RTAKEUCHI 2014/11/26 APPR: KMORIKAWA 2014/12/03	GENERAL TOLERANCES (UNLESS SPECIFIED)		DIMENSION STYLE MM ONLY		SCALE 2:1	DESIGN UNITS METRIC	THIRD ANGLE PROJECTION	
	10 UNDER	±0.2	DRAWN BY HON001	DATE 2014/02/24	TITLE 0.35 BB CONN. H=0.6 SSB6 PLUG ASSY CHECKER TYPE EMBSTP PKG			
	10 OVER 30 UNDER	±0.25	CHECKED BY RTAKEUCHI	DATE 2014/02/24	molex DOCUMENT NO. SD-504622-004 SHEET NO. 3 OF 3			
	30 OVER	±0.3	APPROVED BY KMORIKAWA	DATE 2014/08/11				
ANGULAR ±1°		DRAFT WHERE APPLICABLE MUST REMAIN WITHIN DIMENSIONS		SEE CHART		THIS DRAWING CONTAINS INFORMATION THAT IS PROPRIETARY TO MOLEX INCORPORATED AND SHOULD NOT BE USED WITHOUT WRITTEN PERMISSION		