

PRODUCT NO	MOTOROLA P/N	DIM A	DIM B	DIM C	DIM D	DIM E	DIM F	REMARK
10067099-100LF	3971730C03	3.05MM	1.85MM	3.40MM	1.00MM	1.20MM	3.05MM	NO PROTECTION
10067099-200LF	3971730C02	2.65MM	1.45MM	3.50MM	0.90MM	1.00MM	2.95MM	NO PROTECTION
10067099-400LF	3971730C03	3.05MM	1.85MM	3.40MM	1.00MM	1.20MM	3.05MM	WITH PROTECTION
10067099-500LF	3971730C02	2.65MM	1.45MM	3.50MM	0.90MM	1.00MM	2.95MM	WITH PROTECTION

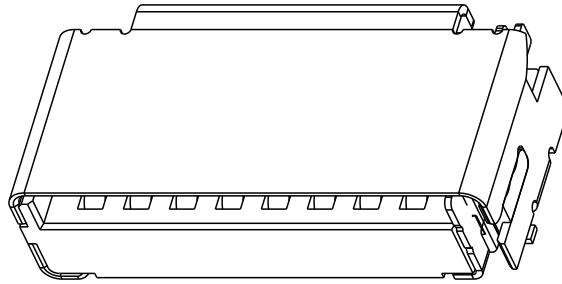

10067099-100LF/200LF

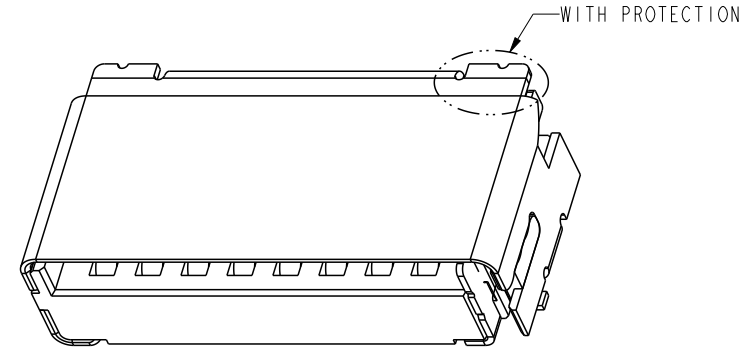

10067099-400LF/500LF

NOTES:

1. MATERIAL:

- HOUSING: 30% G/F LCP, UL 94V-0, COLOR: BLACK.
- CONTACT & DETECT PIN: COPPER ALLOY, THICKNESS=0.15MM.
- CONTACT PLATING: 50u" MIN. OF Ni UNDERPLATE, GOLD FLASH OVER ALL, CONTACT AREA PLATING 30u" GOLD.
- DETECT PIN PLATING: 50u" MIN. OF Ni UNDERPLATE, GOLD FLASH ON CONTACT AREA, TIN PLATED ON SOLDER AREA.
- BRACKET: STAINLESS STEEL, THICKNESS=0.20MM, GOLD FLASH ON SOLDER AREA.

- 2. PRODUCT PERFORMANCE SPEC. PER GS-12-451.
- 3. PACKAGE SPEC. PER GS-14-1162.
- 4. "■" REPRESENT CRITICAL DIMS AND NEED TO MEET C_{pk}>1.5
- 5. THIS PRODUCT IS ROHS COMPLIANT, AND MEETS EUROPEAN UNION DIRECTIVES AND OTHER COUNTRY REGULATIONS AS PER GS-22-008.

spec ref *		dr wcadmin, wcadm		2007/03/30		projection		size A4		scale 4.000	
tolerance std		eng Li-Qing Lei		2022/06/17				mm		ecn no ELX-N-44341-1	
TOLERANCES UNLESS OTHERWISE SPECIFIED		chr -		-						rel level Released	
surface		appr Tim Yao		2022/06/17		product family		rev		10067099	
linear		0.X ±0.30				title TFLASH CONNECTOR ASSEMBLY TFLASH CONNECTOR WITH CARD DETECTING		dwg no		H	
0.XX ±0.15											
0.XXX ±0.08											
angular		0° ±2°		amphenol-icc.com		cat. no. 10067099		Product - Customer Drw		sheet 1 of 3	

PRODUCT NO	MOTOROLA P/N	DIM A	DIM B	DIM C	DIM D	DIM E	DIM F	REMARK
10067099-100LF	3971730C03	3.05MM	1.85MM	3.40MM	1.00MM	1.20MM	3.05MM	NO PROTECTION
10067099-200LF	3971730C02	2.65MM	1.45MM	3.50MM	0.90MM	1.00MM	2.95MM	NO PROTECTION

A

B

C

D

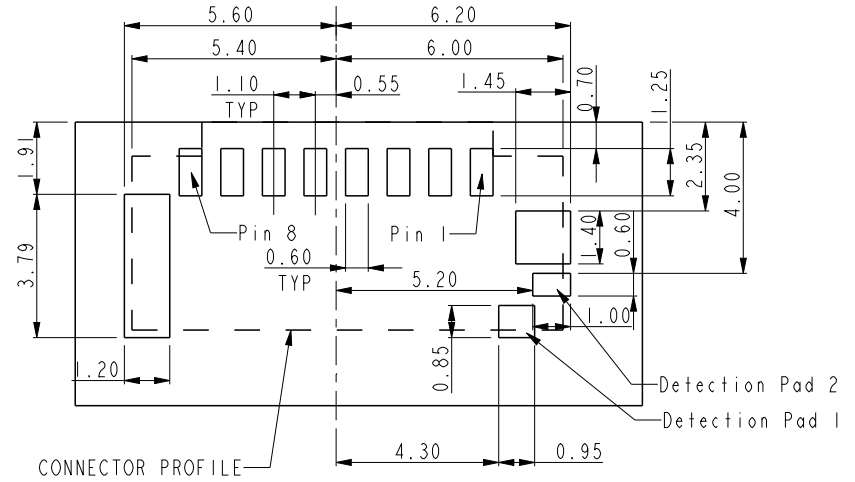
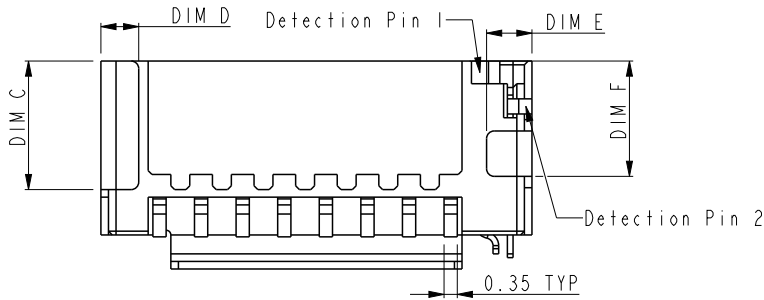
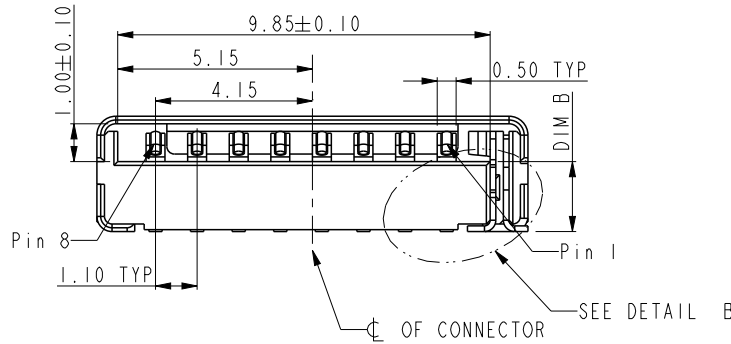
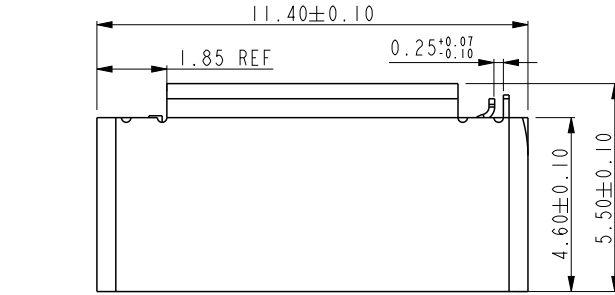
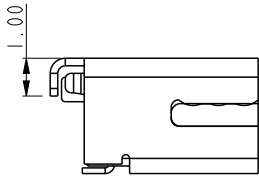

CONNECTOR PROFILE

RECOMMENDED PCB LAYOUT

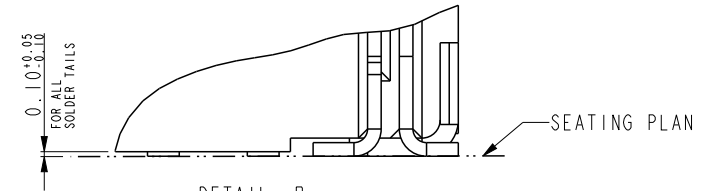
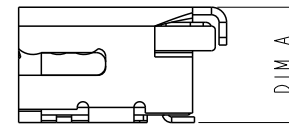

DETAIL B
SCALE 12.000
ALL SOLDER TAILS CO-PLANARITY
FROM SEATING PLANE: 0.08MM MAX.

spec ref	*	dr	wcadmin, wcadm	2007/03/30	projection	mm	size	A4	scale	5.000
tolerance std	TOLERANCES UNLESS OTHERWISE SPECIFIED	eng	Li-Qing Lei	2022/06/17			ecn no	ELX-N-44341-1		
surface	linear	chr	-	-				rel level	Released	
		0.X	±0.30	amphenol-icc.com	title	TFLASH CONNECTOR ASSEMBLY		dwg no	10067099	
0.XX	±0.15	cat. no.	TFLASH CONNECTOR WITH CARD DETECTING		10067099		Product - Customer Drw		sheet 2 of 3	
0.XXX	±0.08	amphenol-icc.com		10067099		Product - Customer Drw		sheet 2 of 3		
angular	0°	±2°		10067099		Product - Customer Drw		sheet 2 of 3		

PRODUCT NO	MOTOROLA P/N	DIM A	DIM B	DIM C	DIM D	DIM E	DIM F	REMARK
10067099-400LF	3971730C03	3.05MM	1.85MM	3.40MM	1.00MM	1.20MM	3.05MM	WITH PROTECTION
10067099-500LF	3971730C02	2.65MM	1.45MM	3.50MM	0.90MM	1.00MM	2.95MM	WITH PROTECTION

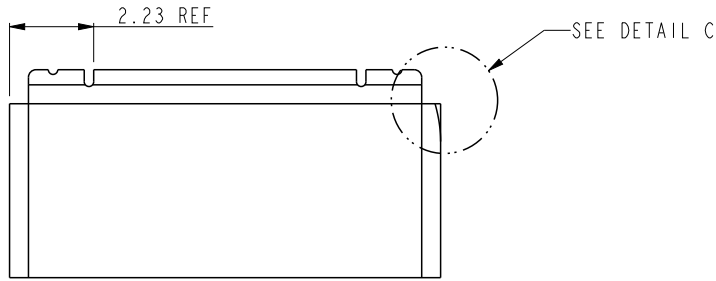
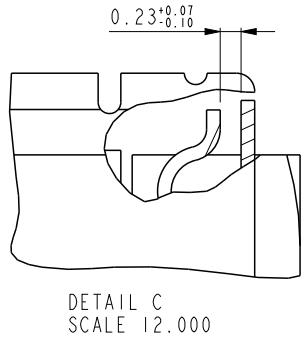

NOTE:
1. TOLERANCE FOR PCB LAYOUT: ±0.05MM.

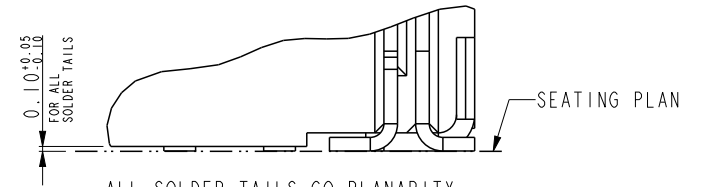
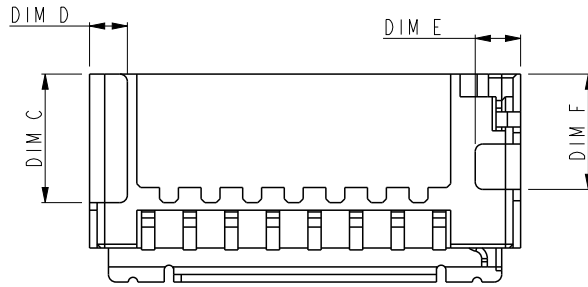
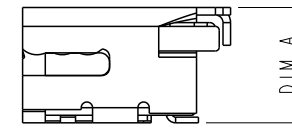
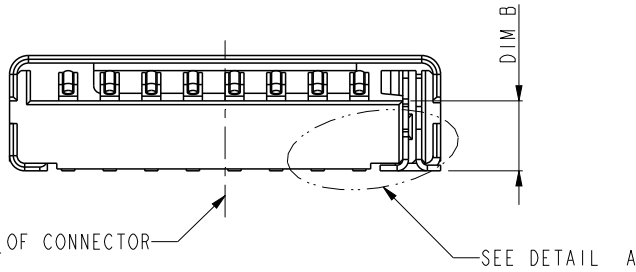
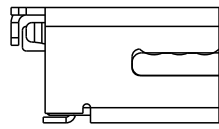

ALL SOLDER TAILS CO-PLANARITY
FROM SEATING PLANE: 0.08MM MAX.

DETAIL A
SCALE 12.000

FOR THE OTHER DIMENSIONS
ARE THE SAME AS -100LF

spec ref	*	dr	wcadmin, wcadm	2007/03/30	projection	mm	size	A4	scale	5.000
tolerance std	TOLERANCES UNLESS OTHERWISE SPECIFIED	eng	Li-Qing Lei	2022/06/17			ecn no		ELX-N-44341-1	
		chr	-	-			rel level		Released	
surface	linear	appr	Tim Yao	2022/06/17	product family			rev		H
	angular	Amphenol FCI		title		TFLASH CONNECTOR ASSEMBLY		dwg no		10067099
	0°	amphenol-icc.com		TFLASH CONNECTOR WITH CARD DETECTING		cat. no.		10067099		Product - Customer Drw
	±0.30									sheet 3 of 3
	±0.15									
	±0.08									
	±2°									