

1/2/4/8 GBPS 850NM VCSEL LC TOSA PACKAGES

HFE7192-XXX

FEATURES:

- LC TOSA HFE7192-x6x includes flex circuit
- LC TOSA HFE7192-x8x leaded package
- High performance VCSEL
- Low electrical parasitic TO package
- Data rates from DC to 8.5Gbps
- Two polarities of Differential versions available
- Complete isolation between the VCSEL and Monitor Photodiode
- Mechanically compatible with SFF, SFP and SFP+ MSAs
- Optional flex circuit interface

The HFE7192-xxx uses a high-performance Vertical Cavity Surface Emitting Laser (VCSEL) designed to meet performance requirements for 1/2/4/8 Gbps data communication over multimode optical fiber for the ANSI X2.T11 Fibre Channel protocols. The optical assembly is designed to interface either 50 μ m or 62.5 μ m multimode fiber and ensure launch conditioning requirements compatibility with enhanced bandwidth fiber as specified by TIA 455-203.

The HFE7192-xxx incorporates a power monitoring photodiode that can be used for temperature compensation, average power control, and for compliance with Class 1 eye safety limits.

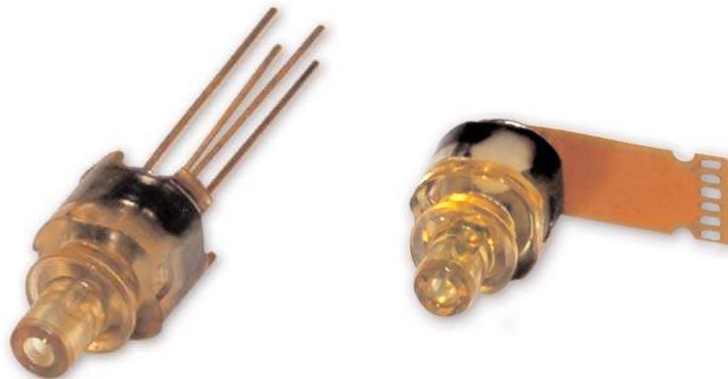

Part Number	Description
HFE7192-581	Differentially Driven, attenuated, LC TOSA, normal polarity
HFE7192-681	Differentially Driven, attenuated, LC TOSA, inverse polarity
HFE7192-561	Differentially Driven, attenuated, LC TOSA, normal polarity, with 50 Ω Flex
HFE7192-661	Differentially Driven, attenuated, LC TOSA, inverse polarity, with 50 Ω Flex

ABSOLUTE MAXIMUM RATINGS

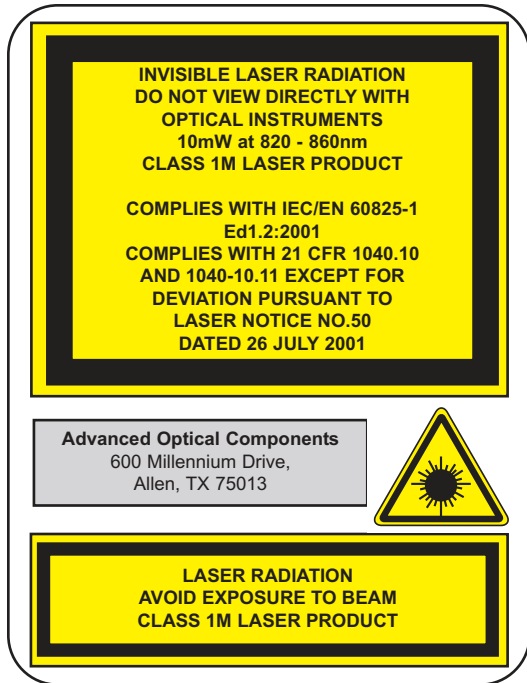

Parameter	Rating
Storage temperature	-40°C to +85°C
Case Operating temperature	-20* to +85°C
Lead solder temperature	260°C, 10 seconds
Reverse Power Supply Voltage	5V
Peak continuous forward current	12mA
ESD Exposure (Human Body Model)	225V ¹

* -20°C operation under assessment.

¹ Heel and wrist straps must be used on a properly grounded workstation.

NOTICE: Stresses greater than those listed under “Absolute Maximum Ratings” may cause permanent damage to the device. This is a stress rating only and functional operation of the device at these or any other conditions above those indicated in the operations section for extended periods of time may affect reliability.

NOTICE: The inherent design of this component causes it to be sensitive to electrostatic discharge (ESD). To prevent ESD-induced damage and/or degradation to equipment, take normal ESD precautions when handling this product.

ELECTRICAL-OPTICAL CHARACTERISTICS

T_A = 25°C unless otherwise stated

VCSEL Parameters	Test Condition	Symbol	Min.	Typ.	Max.	Units	Notes
Fiber coupled optical power	I _F = 6.7mA peak 50/125μm fiber	P _{OC}	360	470		μW	
Coupling Efficiency including wiggler	I _F = 6.7mA	PO_PCT	65			%	1
Threshold Current	T _A =25°C	I _{TH}		1	1.5	mA	
Threshold Current Temperature Variation	T _A = -5° to 85°C	ΔI _{TH}			1.5	mA	2
	T _A = 25° to 85°C				1.5		
	T _A = -5° to 25°C				1.0		
Slope Efficiency	T _A = 25°C, P _{OC} =0.47mW	η	0.065	0.08	0.105	mW/mA	3
	T _A = 85°C, P _{OC} =0.47mW		0.015				
	T _A = -5°C, P _{OC} =0.47mW				0.12		
Slope Efficiency Temperature Variation	T _A =-5 to 85°C	Δη/ΔT		-0.4		%/°C	
Optical Modulation Amplitude		P _{OMA}	480				9
Peak Wavelength	I _F =6.7mA	λ _p	840		860	nm	
λ _p Temperature Variation	T _A =-5 to 85°C	Δλ _p /ΔT		0.06		nm/°C	
RMS Spectral Bandwidth		Δλ			0.65	nm	9
Laser Forward Voltage	I _F =6.7mA	V _F	1.5	1.8	2.2	V	
Laser Reverse Voltage	I _R = 10μA	V _R	5	10		V	
Rise/Fall Time	Bias above threshold 20%-80%	T _R			50	ps	4
		T _F			50		
Relative Intensity Noise		RIN ₁₂			-128	dB/Hz	5,9
Series Resistance	T _A = 25°C, I _F =6.7mA	R	35	50	60	Ohms	9
	T _A = 85°C		25				
	T _A = -5°C				75		
Series Resistance Temperature Variation	I _F =6.7mA	ΔR/ΔT		-0.2		%/°C	
Encircled Flux Diameter		EF					6,9

Photodiode Parameters	Test Condition	Symbol	Min.	Typ.	Max.	Units	Notes
Monitor Current	P _{OC} =0.47mW, V _R =3V	I _{PD}	100	250	500	μA	
Monitor Current Temperature Variation	P _{OC} =0.47mW T _A = -5 to 85°C	ΔI _{pd} /ΔIT		0.0		%/°C	
Tracking Ratio Variation (Open Bore)	P _{OB} =-2.5dBm T _A = -5 to 85°C	ΔTR	-0.5		+0.5	dB	
Dark Current	P _{OC} =0mW, V _R =3V	I _{DARK}			20	nA	
PD Reverse Voltage	P _{OC} =0mW, I _R =10μA	BVR _{PD}	30	115		V	7
PD Capacitance	V _R =0V, Freq=1MHz V _R =3V, Freq=1MHz	C _{PD}		75	100	pF	
				40	55		

NOTES

1. PO_PCT is defined as the ratio of the coupled power into a 50/125 micron fiber to the total power output from the optical front end as measured on a large area detector.
2. Operation outside of the specified range may result in the threshold current exceeding the maximums defined in the electro-optical characteristics table. ΔI_{TH} is the maximum deviation from the 25°C value.
3. Slope efficiency is defined as $\Delta P_O / \Delta I_F$ at a total power output of 0.47mW. Slope efficiency is intentionally lowered to the value shown by attenuation. See recommended Bias Profile below for P_{OC} setup details.
4. Rise and fall times are sensitive to drive electronics. Rise and fall times are measured 20%-80% using a 1GHz square wave AC coupled to the VCSEL using a bias-T. The DC current is adjusted to achieve a minimum OMA of -4dBm. Corrections are made for finite detector bandwidth.
5. RIN_{12} is measured using the OMA technique with 12dB return.
6. Encircled flux is measured per TIA-455-203.
7. To prevent VCSEL damage, short the VCSEL anode and cathode during BVR testing of the photodiode.
8. Operation of the HFE7192-xxx is critically dependent upon the quality of the electrical interface between the TO can and the customer PCB. All specifications are tested with the optional flex interface circuit. Modulation performance without the flex circuit will be impaired
9. Using recommended bias profile shown below. OMA level is for beginning of life and accounts for aging.

RECOMMENDED BIAS PROFILE

In order to maintain maximum output quality while maintaining an ample high temperature margin for reliability and rollover, a temperature dependent bias profile is recommended. To define this profile, the back monitor current IPD needs to be measured for a fiber coupled power of -3, -3.3, and -3.5 dBm, respectively. The BOL tracking profile then includes the recorded IPD values at -3 dBm for -5C, -3.3 dBm for 25C, and -3.5 dBm at 85C. This programming can be derived from room temperature measurements; measurement over temperature can be used for increased accuracy.

PINOUT

PIN	HFE7192-581	HFE7192-681	PIN	HFE7192-561 (Flex)	HFE7192-661 (Flex)
1	Case	Case	1	MPD Cathode	MPD Cathode
2	VCSEL Anode	VCSEL Cathode	2	Case	Case
3	MPD Cathode	MPD Cathode	3	VCSEL Anode	VCSEL Cathode
4	MPD Anode	MPD Anode	4	VCSEL Cathode	VCSEL Anode
5	VCSEL Cathode	VCSEL Anode	5	Case	Case
			6	MPD Anode	MPD Anode

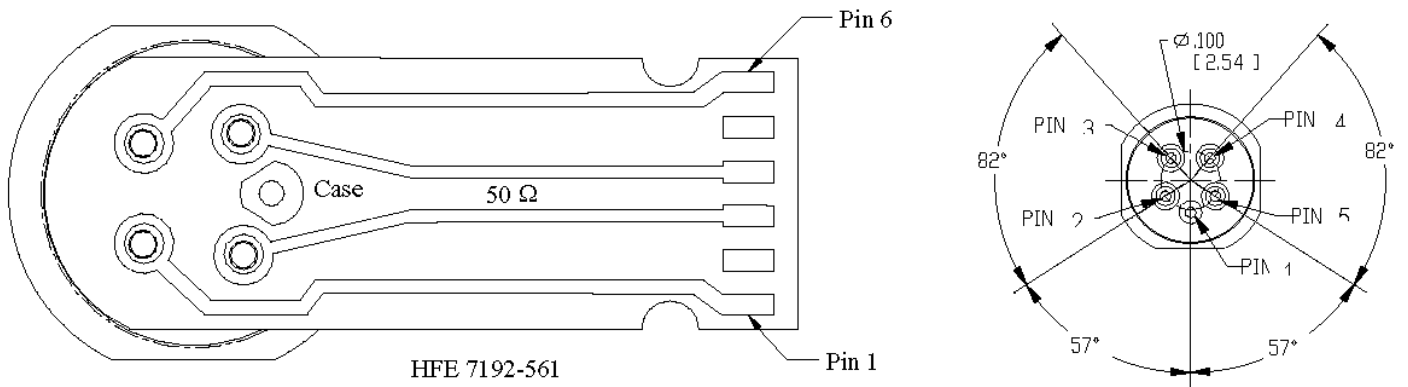

MOUNTING DIMENSIONS - LC TOSA HFE7192-X81

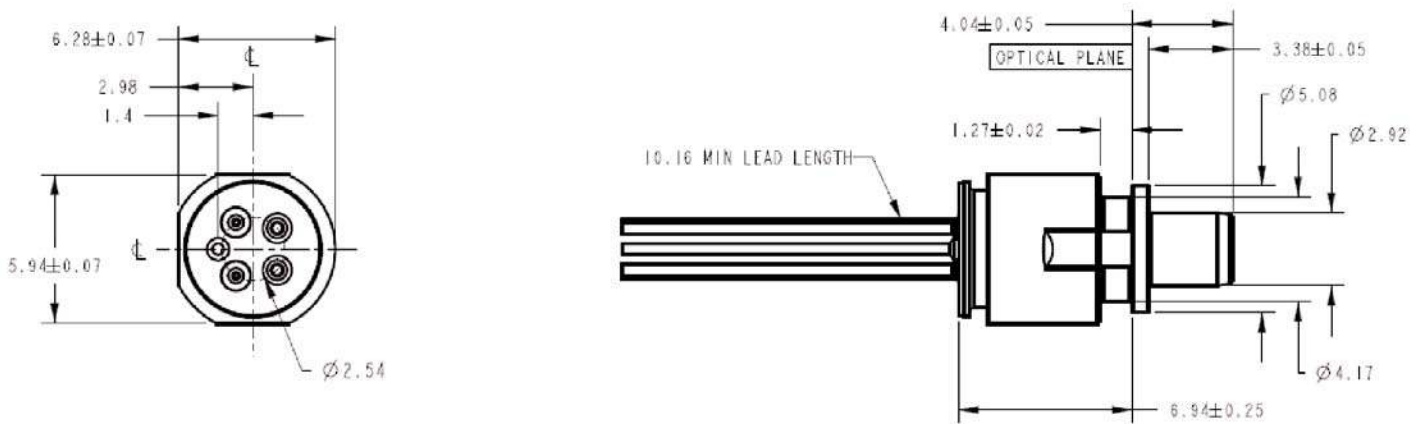

MOUNTING DIMENSIONS (for reference only): All dimensions in mms.

MOUNTING DIMENSIONS - LC TOSA

(for reference only):
All dimensions in mms.

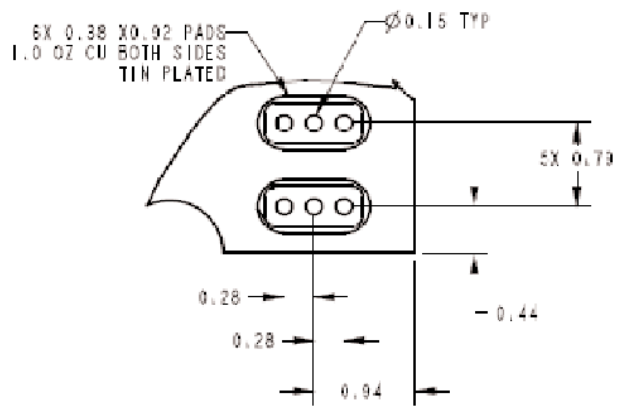
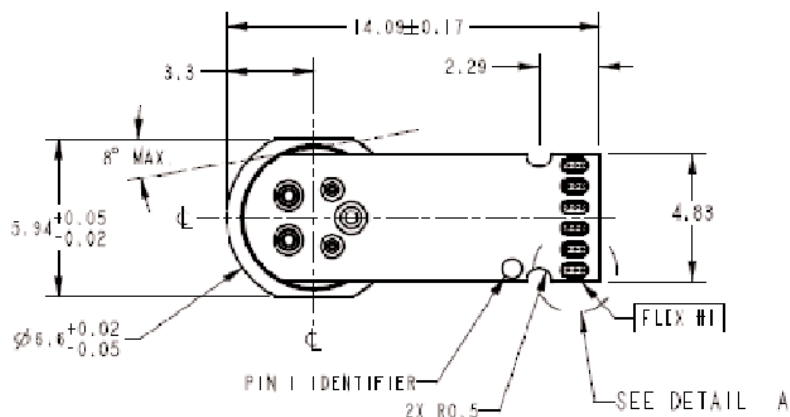

DETAIL A
SCALE 20

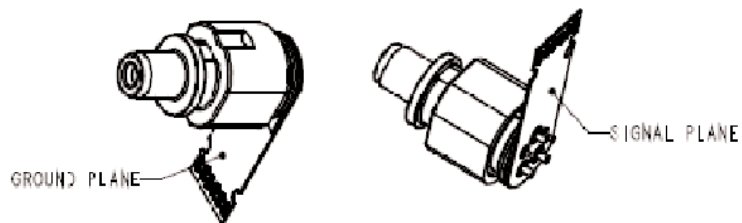
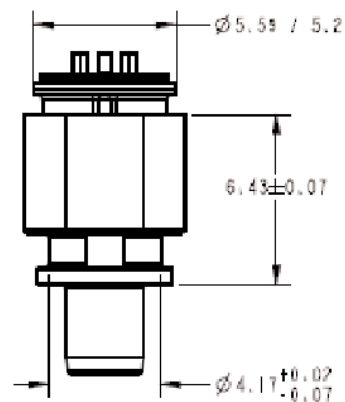
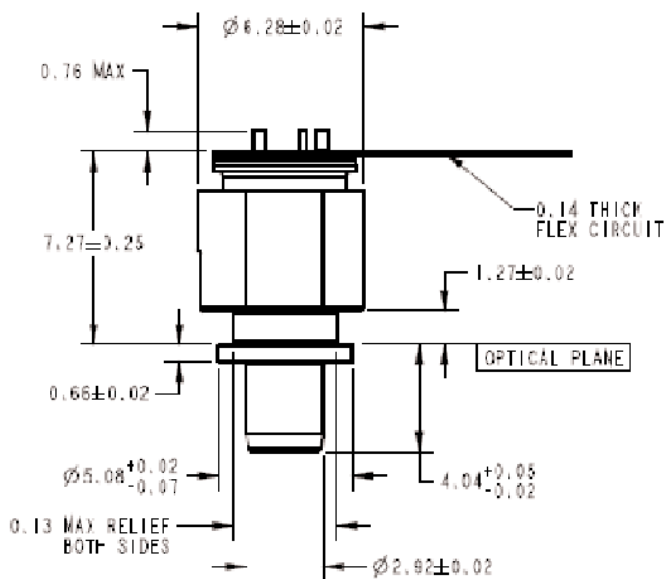

ADVANCED OPTICAL COMPONENTS

Finisar's ADVANCED OPTICAL COMPONENTS division was formed through strategic acquisition of key optical component suppliers. The company has led the industry in high volume Vertical Cavity Surface Emitting Laser (VCSEL) and associated detector technology since 1996. VCSELS have become the primary laser source for optical data communication, and are rapidly expanding into a wide variety of sensor applications. VCSELS' superior reliability, low drive current, high coupled power, narrow and circularly symmetric beam and versatile packaging options (including arrays) are enabling solutions not possible with other optical technologies. ADVANCED OPTICAL COMPONENTS is also a key supplier of Fabrey-Perot (FP) and Distributed Feedback (DFB) Lasers, and Optical Isolators (OI) for use in single mode fiber data and telecommunications networks

LOCATION

- Allen, TX - Business unit headquarters, VCSEL wafer growth, wafer fabrication and TO package assembly.
- Fremont, CA – Wafer growth and fabrication of 1310 to 1550nm FP and DFB lasers.
- Shanghai, PRC – Optical passives assembly, including optical isolators and splitters.

SALES AND SERVICE

Finisar's ADVANCED OPTICAL COMPONENTS division serves its customers through a worldwide network of sales offices and distributors. For application assistance, current specifications, pricing or name of the nearest Authorized Distributor, contact a nearby sales office or call the number listed below.

AOC CAPABILITIES

ADVANCED OPTICAL COMPONENTS' advanced capabilities include:

- 1, 2, 4, 8, and 10Gbps serial VCSEL solutions
- 1, 2, 4, 8, and 10Gbps serial SW DETECTOR solutions
- VCSEL and detector arrays
- 1, 2, 4, 8, and 10Gbps FP and DFB solutions at 1310 and 1550nm
- 1, 2, 4, 8, and 10Gbps serial LW DETECTOR solutions
- Optical Isolators from 1260 to 1600nm range
- Laser packaging in TO46, TO56, and Optical subassemblies with SC, LC, and MU interfaces for communication networks
- VCSELS operating at 670nm, 780nm, 980nm, and 1310nm in development
- Sensor packages include surface mount, various plastics, chip on board, chip scale packages, etc.
- Custom packaging options

Finisar

Advanced Optical Components Division

Phone: 1-866-MY-VCSEL USA (toll free)
1-214-509-2700 USA (Direct dial)
44 (0) 174 336 5533 Europe
886-935-409898 China & Taiwan
81-90-4437-1130 Japan
82-11-220-6153 Asia Pacific & Korea

Fax: 1-214-509-3709 USA

Email: support@adopco.com
WEB: www.finisar.com/aoc.php