

Wire Wound Magnetically Shielded SMD Power Inductor

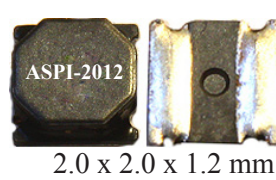

ASPI-2012 series



RoHS/RoHS II Compliant

FEATURES:

- Small size and low profile: 1.2mm
- Small DCR and high rated current
- High reliability to mechanical stress
- Magnetically shielded by magnetic powder molding
- Suitable for RoHS reflow profile

APPLICATIONS:

- Mobile phones
- MP3 & 4 and other portable communication equipment
- Digital cameras.

ELECTRICAL SPECIFICATIONS:

Abracon P/N:	ASPI-2012 series
Operating Temperature & Humidity :	-40°C ~ +125°C (including self heating)
Storage Temperature & Humidity:	-10°C ~ +40°C and 70% R.H. max.

Part Number ASPI-2012- Inductance Code	Inductance	L Tolerance	DC Resistance Typ	DC Resistance Max	Saturation Current Max	Saturation Current Typ	Temperature Rise Current Max	Temperature Rise Current Typ
Units	µH	—	Ω Typ	Ω Max	A Max	A Typ	A Max	A Typ
Symbol	L	M	DCR		Isat		Irms	
ASPI-2012-R16	0.16	M	0.026	0.031	5.20	5.80	2.50	2.75
ASPI-2012-R24	0.24	M	0.035	0.042	4.70	5.20	2.20	2.40
ASPI-2012-R33	0.33	M	0.035	0.042	3.50	4.00	2.20	2.40
ASPI-2012-R47	0.47	M	0.042	0.050	3.55	3.75	2.00	2.20
ASPI-2012-R68	0.68	M	0.050	0.060	2.95	3.10	1.80	2.00
ASPI-2012-1R0	1.0	M	0.073	0.088	2.70	2.85	1.50	1.65
ASPI-2012-1R5	1.5	M	0.093	0.112	2.00	2.20	1.30	1.45
ASPI-2012-2R2	2.2	M	0.106	0.127	1.40	1.65	1.20	1.35
ASPI-2012-3R3	3.3	M	0.230	0.276	1.20	1.35	0.85	0.95
ASPI-2012-4R7	4.7	M	0.245	0.294	0.97	1.10	0.82	0.90
ASPI-2012-6R8	6.8	M	0.399	0.479	0.82	0.92	0.64	0.70
ASPI-2012-100	10	M	0.654	0.785	0.72	0.82	0.49	0.54
ASPI-2012-150	15	M	1.140	1.368	0.55	0.65	0.38	0.42
ASPI-2012-180	18	M	1.400	1.680	0.60	0.68	0.35	0.38
ASPI-2012-220	22	M	1.400	1.680	0.40	0.50	0.35	0.38
ASPI-2012-330	33	M	1.800	2.160	0.35	0.40	0.30	0.33

Test Conditions:

- Ambient Temperature: 20± 15°C
- Relative Humidity: 65%±20%
- Air Pressure: 86KPa to 106KPa

Inductance (L): WK3260B LCR meter or equivalent, 1MHz

Direct Current Resistance (DCR): HIOKI 3540 or equivalent

Saturation Current (I_{sat}): WK3260B LCR meter or equivalent

I_{sat} max. is the DC current at which the inductance drops less than 30% from its value without current.

I_{sat} typ. is the DC current at which the inductance drops approximate 30% from its value without current.

Temperature rise current (I_{rms}): Electric Power, Electric current meter, Thermometer

For I_{rms} max, ΔT<40°C. For I_{rms} typ, ΔT is approximate 40°C.

ABRACON IS
ISO9001:2008
CERTIFIED



ABRACON
CORPORATION

Visit www.abracon.com for Terms & Conditions of Sale

30332 Esperanza, Rancho Santa Margarita, California 92688
tel 949-546-8000 | fax 949-546-8001 | www.abracon.com

Revised: 12.18.13

Wire Wound Magnetically Shielded SMD Power Inductor

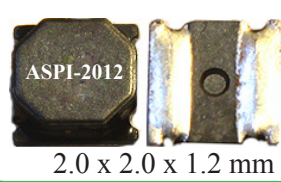

ASPI-2012 series

RoHS/RoHS II Compliant

ELECTRICAL CHARACTERISTICS CURVES

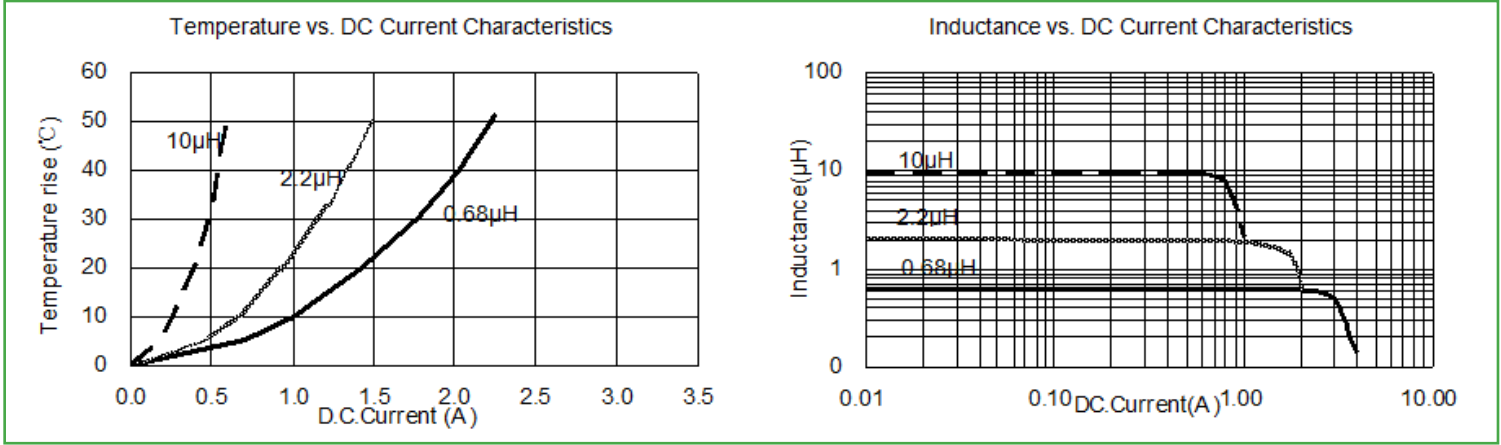

PART IDENTIFICATION:

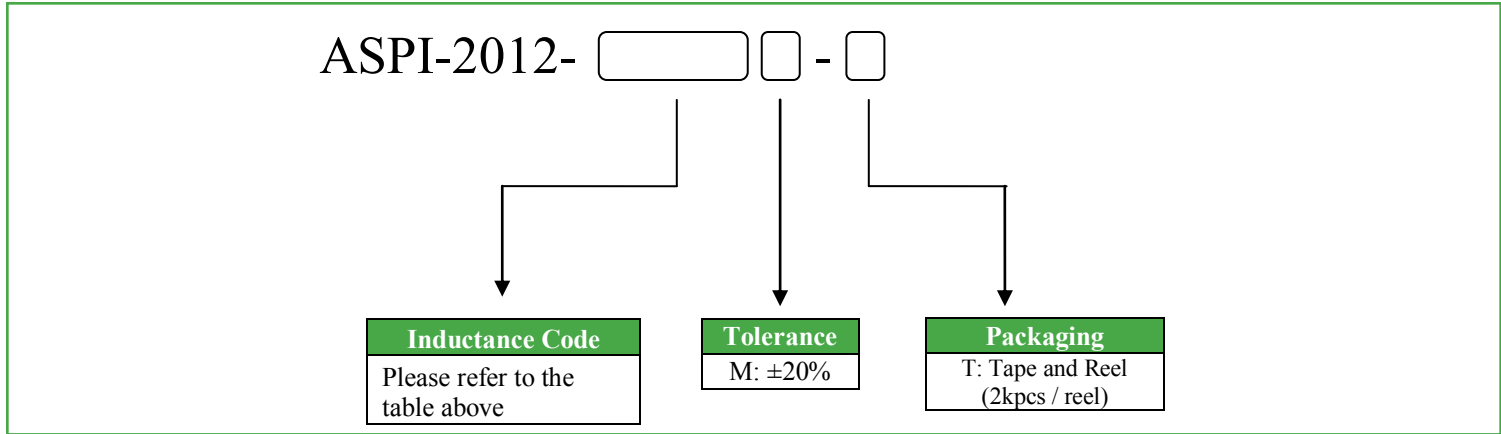

OUTLINE DIMENSION:

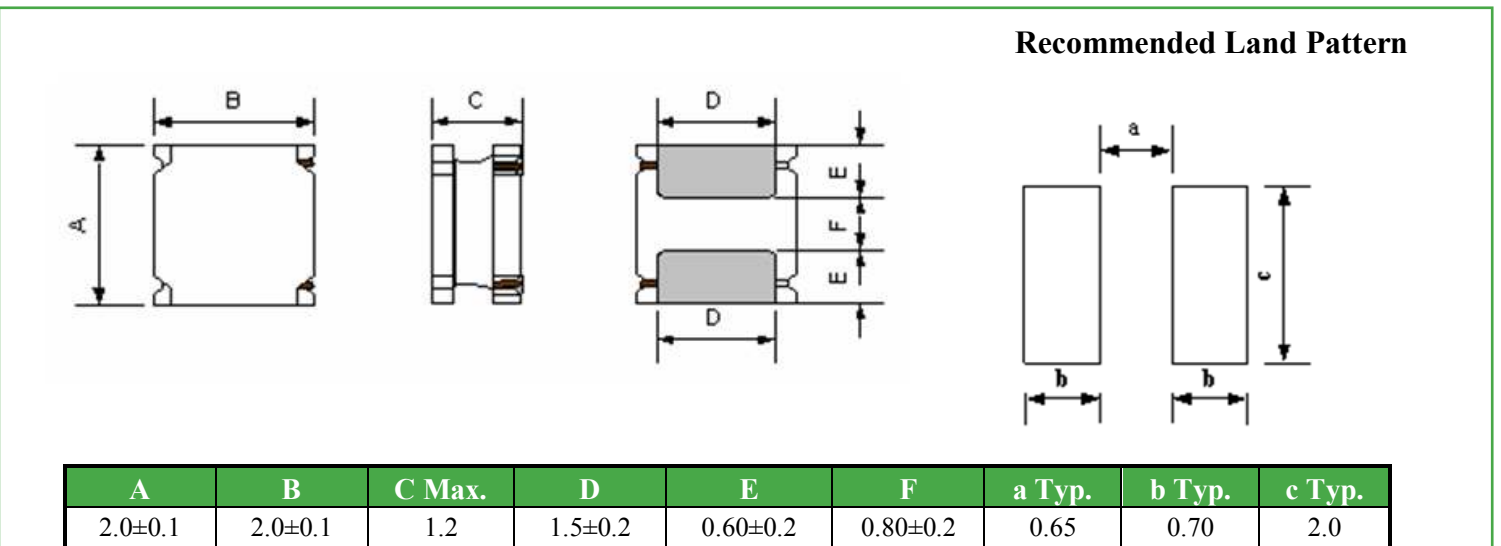

Dimensions: mm

Wire Wound Magnetically Shielded SMD Power Inductor

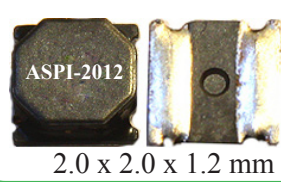

ASPI-2012 series

RoHS/RoHS II Compliant

MATERIAL:

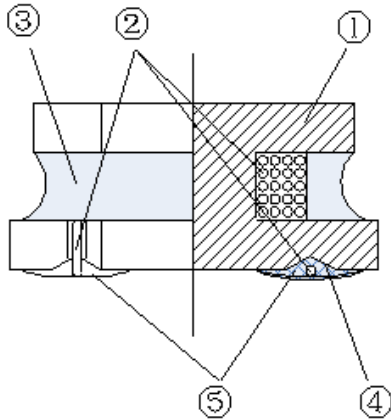

No	Components	Material
1	Ferrite Core	Ni-Zn Ferrite
2	Wire	Polyurethane System enameled copper wire
3	Magnetic Glue	Epoxy resin and magnetic powder
4	Plating Electrodes	Plating: Ag/Ni/Sn
5	Outer Electrodes	Top surface solder coating: Sn96.5%/Ag3%/Cu0.5%

REFLOW PROFILE:

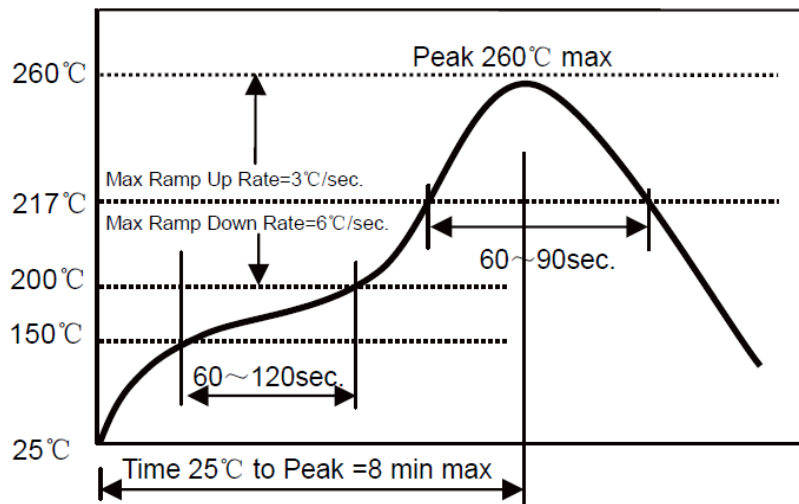

- △ Preheat condition: 150 ~200°C /60~120sec.
- △ Allowed time above 217°C: 60~90sec.
- △ Max temp: 260°C
- △ Max time at max temp: 5sec.
- △ Solder paste: Sn/3.0Ag/0.5Cu
- △ Allowed Reflow time: 2x max

Wire Wound Magnetically Shielded SMD Power Inductor



ASPI-2012 series



RoHS/RoHS II Compliant

TAPE & REEL:

T: 2,000pcs / reel

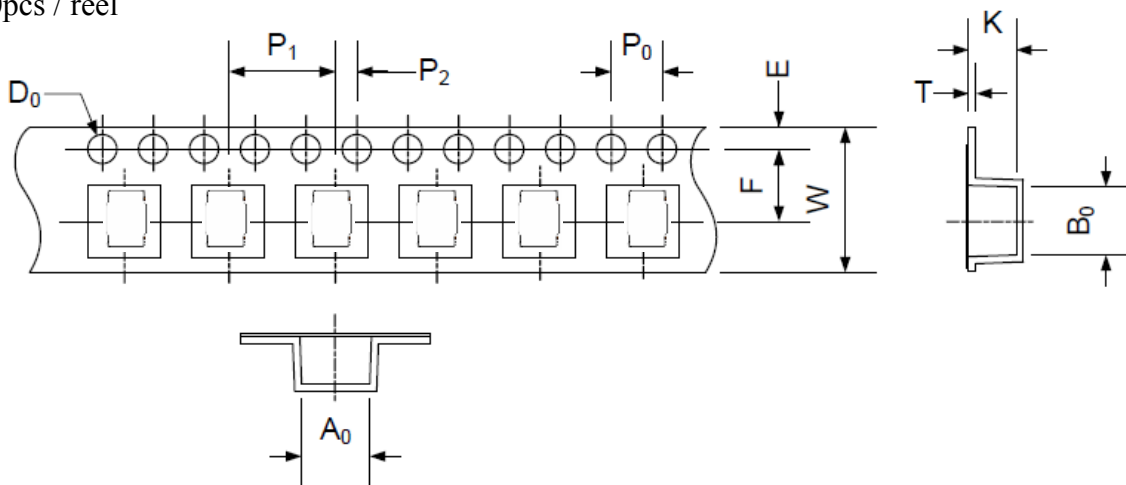

A ₀	B ₀	W	E	F	P ₀	P ₁	P ₂	D ₀	T	K ₀
2.35±0.05	2.35±0.05	8.0±0.1	1.75±0.1	3.5±0.05	4.0±0.1	4.0±0.1	2.0±0.05	1.5+0.1/-0.0	0.25±0.02	1.40±0.05

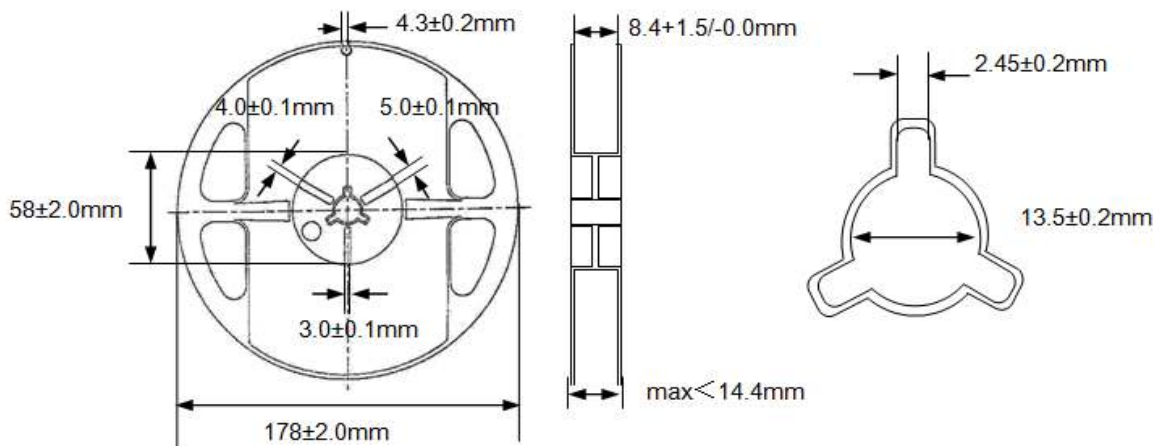

Storage Conditions

- To maintain the solderability of terminal electrodes and to keep the packing material in good condition, temperature and humidity in the storage area should be controlled.
- Recommended conditions: -10°C ~ +40 °C, 70% RH (Max.)
- Even under ideal storage conditions, solderability of products electrodes may decrease as time passes. For this reason, product should be used within one year from the time of delivery.
- In case of storage over 6 months, solderability shall be checked before actual usage.

Dimension: mm

ATTENTION: Abracon Corporation's products are COTS – Commercial-Off-The-Shelf products; suitable for Commercial, Industrial and, where designated, Automotive Applications. Abracon's products are not specifically designed for Military, Aviation, Aerospace, Life-dependant Medical applications or any application requiring high reliability where component failure could result in loss of life and/or property. For applications requiring high reliability and/or presenting an extreme operating environment, written consent and authorization from Abracon Corporation is required. Please contact Abracon Corporation for more information.

ABRACON IS
ISO9001:2008
CERTIFIED



Visit www.abracon.com for Terms & Conditions of Sale
30332 Esperanza, Rancho Santa Margarita, California 92688
tel 949-546-8000 | fax 949-546-8001 | www.abracon.com

Revised: 12.18.13