

REVISIONS					
REV	ECO	DESCRIPTION	DATE	BY	APPR
A1	-	RELEASE NEW DWG FORMAT	Oct.06,2014	Tod	Tommy
A2	-	UPDATE THE DURABILITY	Jun.27,2015	Drack	Tommy
A3	-	UPDATED	04DEC15	MRF	Tommy

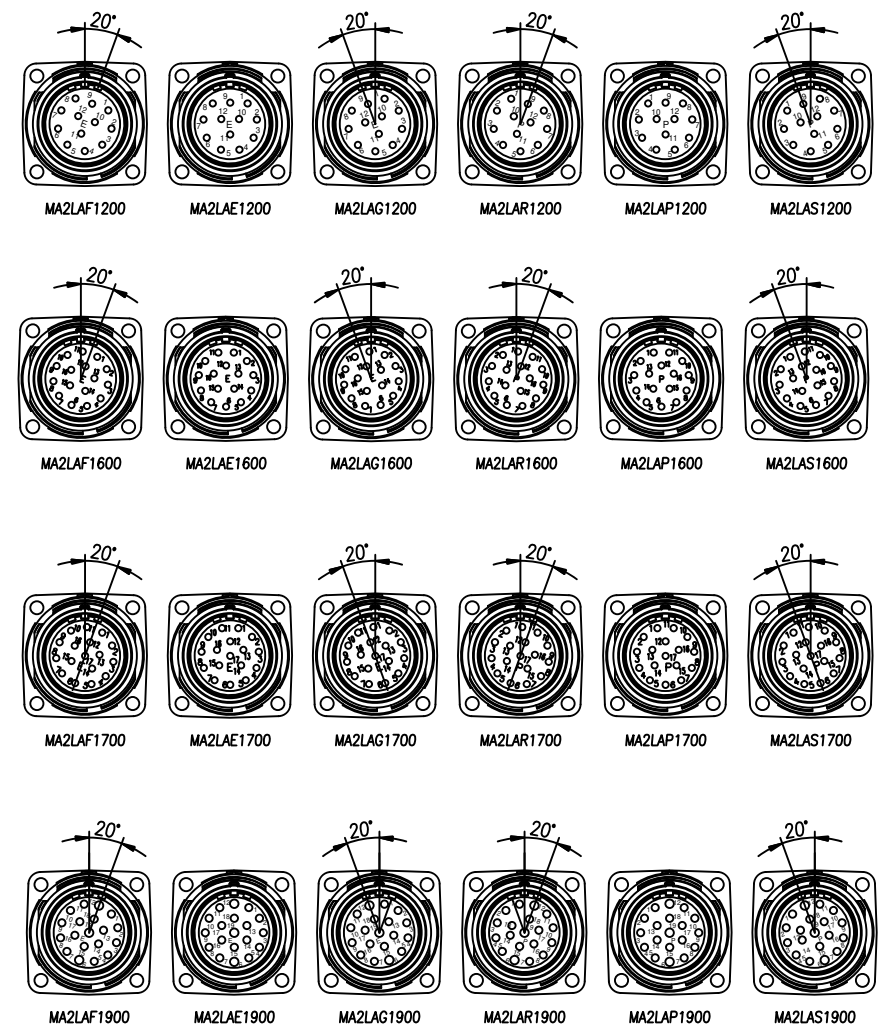
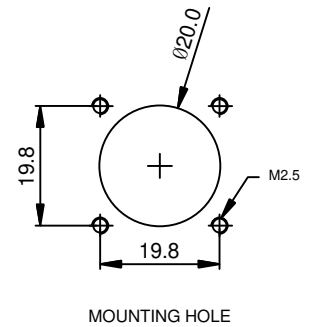
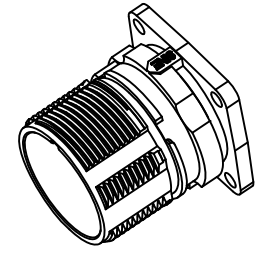
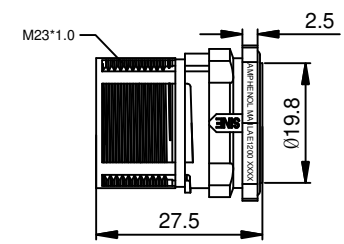
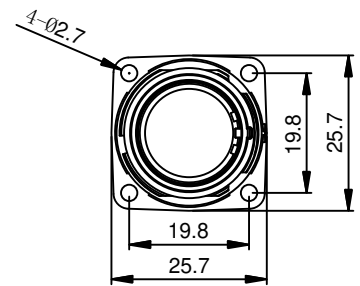

-	MA2LAS1900	M23, RECP, ST, 19POS, P TYPE, KEYED "S"	27
-	MA2LAR1900	M23, RECP, ST, 19POS, P TYPE, KEYED "R"	26
-	MA2LAP1900	M23, RECP, ST, 19POS, P TYPE	25
-	MA2LAG1900	M23, RECP, ST, 19POS, E TYPE, KEYED "G"	24
-	MA2LAF1900	M23, RECP, ST, 19POS, E TYPE, KEYED "F"	23
-	MA2LAE1900	M23, RECP, ST, 19POS, E TYPE	22
-	MA2LAS1700	M23, RECP, ST, 17POS, P TYPE, KEYED "S"	20
-	MA2LAR1700	M23, RECP, ST, 17POS, P TYPE, KEYED "R"	19
-	MA2LAP1700	M23, RECP, ST, 17POS, P TYPE	18
-	MA2LAG1700	M23, RECP, ST, 17POS, E TYPE, KEYED "G"	17
-	MA2LAF1700	M23, RECP, ST, 17POS, E TYPE, KEYED "F"	16
-	MA2LAE1700	M23, RECP, ST, 17POS, E TYPE	15
-	MA2LAS1600	M23, RECP, ST, 16POS, P TYPE, KEYED "S"	13
-	MA2LAR1600	M23, RECP, ST, 16POS, P TYPE, KEYED "R"	12
-	MA2LAP1600	M23, RECP, ST, 16POS, P TYPE	11
-	MA2LAG1600	M23, RECP, ST, 16POS, E TYPE, KEYED "G"	10
-	MA2LAF1600	M23, RECP, ST, 16POS, E TYPE, KEYED "F"	9
-	MA2LAE1600	M23, RECP, ST, 16POS, E TYPE	8
-	MA2LAS1200	M23, RECP, ST, 12POS, P TYPE, KEYED "S"	6
-	MA2LAR1200	M23, RECP, ST, 12POS, P TYPE, KEYED "R"	5
-	MA2LAP1200	M23, RECP, ST, 12POS, P TYPE	4
-	MA2LAG1200	M23, RECP, ST, 12POS, E TYPE, KEYED "G"	3
-	MA2LAF1200	M23, RECP, ST, 12POS, E TYPE, KEYED "F"	2
-	MA2LAE1200	M23, RECP, ST, 12POS, E TYPE	1

QUANTITY	PART NUMBER	DESCRIPTION	ITEM
----------	-------------	-------------	------

MATERIALS LIST											
UNLESS OTHERWISE SPECIFIED 1) All dimensions are in metric(mm). 2) Tolerances are as follows: 1 PL DEC ±0.30 2 PL DEC ±0.15 3 PL DEC ±0.08	SIGNATURES DRAWN: Drack CHECKED: ENGINEER: APPROVAL:	DATE Jun.27,2015	<h1>Amphenol</h1> <p>Sine Systems - www.amphenol-sine.com 44724 Morley Drive Clinton Township, MI 48036</p>								
MATERIAL SPECIFICATIONS:	CUSTOMER:										
PROCESS SPECIFICATIONS:	THIS DRAWING IS SUPPLIED FOR INFORMATION ONLY. DESIGN FEATURES, SPECIFICATIONS AND PERFORMANCE DATA SHOWN HEREON ARE THE PROPERTY OF THE AMPHENOL CORPORATION. NO RIGHTS OF REPRODUCTION ARE IMPLIED. ALL DIMENSIONS ARE SUBJECT TO NORMAL MANUFACTURING VARIATIONS.		<table border="1"> <tr> <td>SIZE</td> <td>TYPE</td> <td>DWG NO.</td> <td>REVISION</td> </tr> <tr> <td>B</td> <td>C-</td> <td>MA2LAxxx00</td> <td>A3</td> </tr> </table>	SIZE	TYPE	DWG NO.	REVISION	B	C-	MA2LAxxx00	A3
SIZE	TYPE	DWG NO.	REVISION								
B	C-	MA2LAxxx00	A3								
NEXT ASSY:	SCALE: NONE	C-MA2LAxxx00	SHEET 1 OF 1								

- NOTES: UNLESS OTHERWISE SPECIFIED
- MATERIAL:
INSULATION INSERT: PA66,UL94 V0
SEAL: VITON
HOUSING BODY: ZINC DIE CAST, NICKEL PLATED
 - SPECIFICATIONS:
 - CURRENT RATING: 10 AMPS - 12 POSITION
9 AMPS - 16 POSITION
9 AMPS - 17 POSITION
7 AMPS - 19 POSITION
 - VOLTAGE RATING: 160V AC/DC - 12 POSITION
125V AC/DC - 16 POSITION
125V AC/DC - 17 POSITION
63V AC/DC - 19 POSITION
 - OPERATING TEMPERATURE: -20°C TO +130°C
 - DIELECTRIC WITHSTANDING VOLTAGE: LESS THAN 2 MILLIAMPS CURRENT LEAKAGE @ 2500 VOLTS AC.
 - DEGREE OF PROTECTION: IP67 (MATED CONDITION)
 - DEGREE OF POLLUTION: 3 PER UL840
 - OVERVOLTAGE CATEGORY: III PER UL840
 - MATING CYCLE DURABILITY: >500 CYCLES
 - RoHS COMPLIANT
 - ALL DIMENSIONS ARE FOR REFERENCE USE ONLY.

TITLE: M23 RECEPTACLE, STRAIGHT, CHECKMATE
DWG NO.: MA1LAXX00
REV: A3
SH: 1
OF: 1