

NOTES:

1. PARTS ARE TO BE BULK PACKED.
2. PARENTHESIS () INDICATE REFERENCE DIMENSION.
3. BRACKETS [] INDICATE METRIC DIMENSIONS.

ASS'Y P/N	CABLE O.D.
16880-4SG-518W	0.175 - 0.185 [4.4-4.7]
16880-4SG-521W	0.205 - 0.215 [5.2-5.5]
16880-4SG-522W	0.215 - 0.225 [5.5-5.7]

GROMMET SIZE

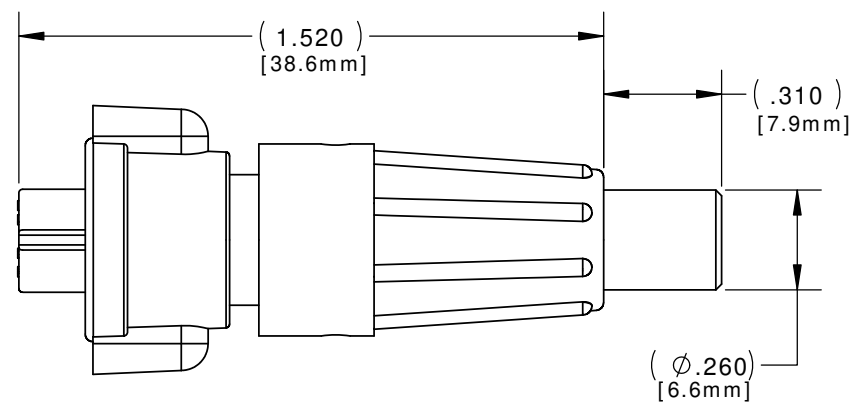
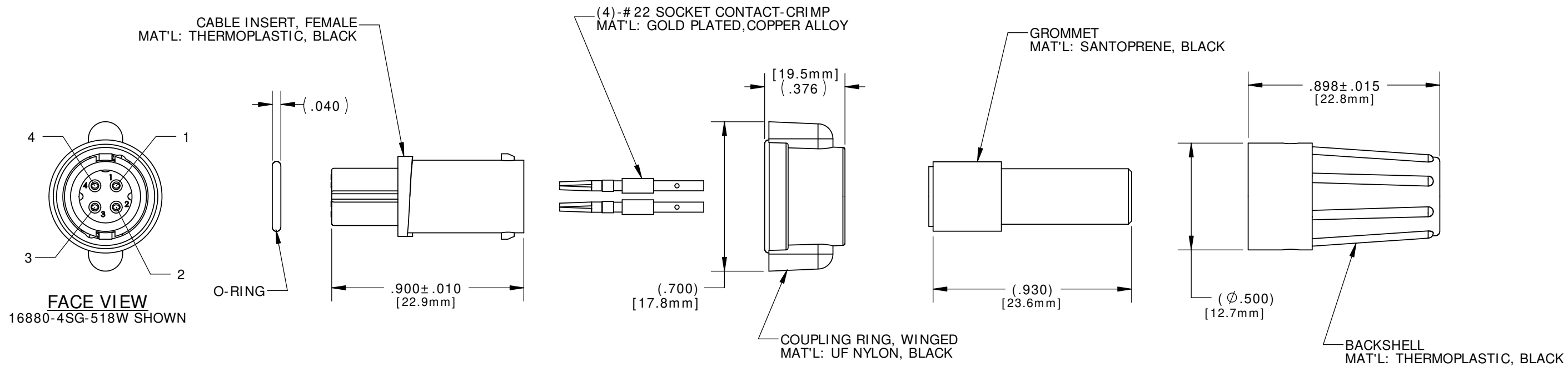

CUSTOMER APPROVAL

THIS DOCUMENT CONTAINS CONFIDENTIAL INFORMATION PROPRIETARY TO CONXALL CORPORATION. ANY REPRODUCTION, DISCLOSURE, OR USE OF THIS DOCUMENT / INFORMATION IS EXPRESSLY PROHIBITED UNLESS AUTHORIZED IN WRITING BY CONXALL CORPORATION.

APPROVED BY: _____

DATE: _____

RoHS COMPLIANT

A	JD	03/25/14	DRAWING CREATED PER DOR 14-E149SL(6)	
REV.	INIT.	DATE	DESCRIPTION	
	JD	03/25/14	ALL INFORMATION ILLUSTRATED IS THE PROPERTY OF CONXALL CORPORATION. UNAUTHORIZED DUPLICATION OR DISTRIBUTION OF THIS DOCUMENT IS PROHIBITED.	
ALL UNITS ARE IN FEET, INCHES, FRACTION OF INCHES AND DECIMALS.			APPROVED BY: _____ TITLE: CABLE CONNECTOR KIT (4)-#22 SOCKET CONTACT, CRIMP MICRO-CON-X, 4 POS. STANDARD PRODUCT	
SCALE	SIZE	SHEET	CUSTOMER: 601 E. WILDWOOD VILLA PARK, IL 60181	
NTS	B	11 OF 1	PART NUMBER: 16880-4SG-5XXW	
FILE:	DIRECTORY:	PART	REV	
16880-4SG-5XXW	SLW	NUMBER:	A	